

PART NUMBER	REV	FIRST USED
567469-1	C	354500-1
567469-2	C	565435-5

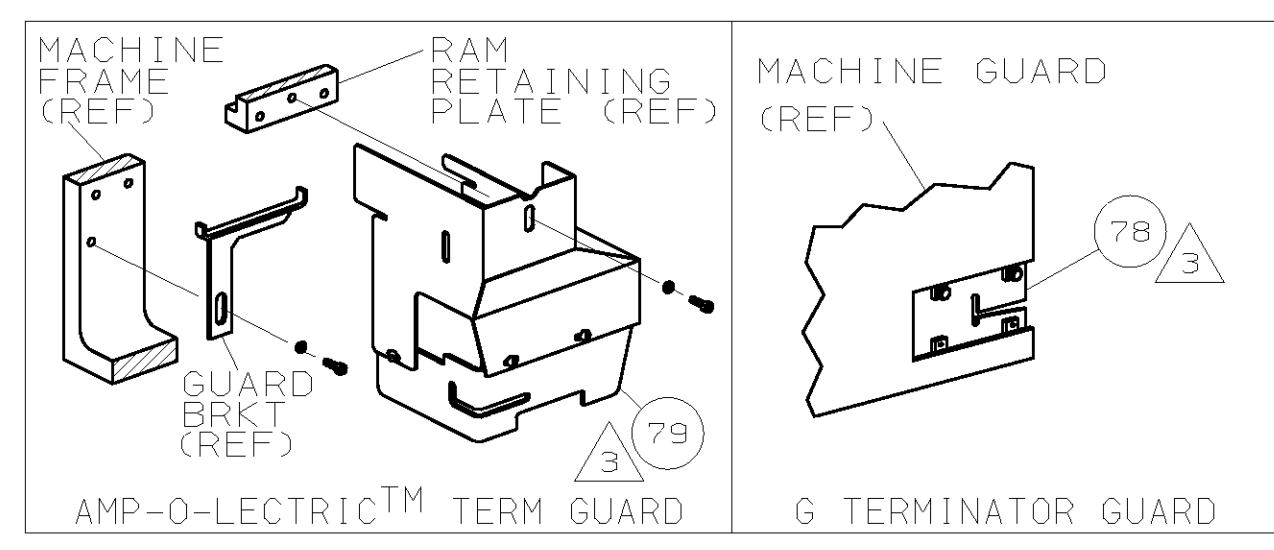

TERMINAL NAME: TAB, FASTIN-FASTON™ AMPLIVAR, .187 SERIES		62447-2	
PAD LTR	CRIMP HEIGHT	WIRE SIZE	
A	.059 ±.002 [1.50 ±0.05mm]	(1)21 & (1)22	
B	.054 ±.002 [1.37 ±0.05mm]	21 or 22	
C	NOT	USED	
D	NOT	USED	
CRIMP	SIZE	TYPE	RANGE
WIRE	.110 [2.79mm]	F	22-21
INSUL	-	-	-
WIRE STRIP LENGTH	TERM APPL SPEC	FEED	APPL INSTRUCTION
-	114-2146	1.065	408-8039
		SET UP GAGE	LAYOUT
		458638-1	L1469

REV	BENCH MODEL	AIR FEED	ITEM NO
-1	BENCH MODEL G	AIR FEED	
-2	BENCH MODEL K	AIR FEED	

THIS DRAWING IS A CONTROLLED DOCUMENT

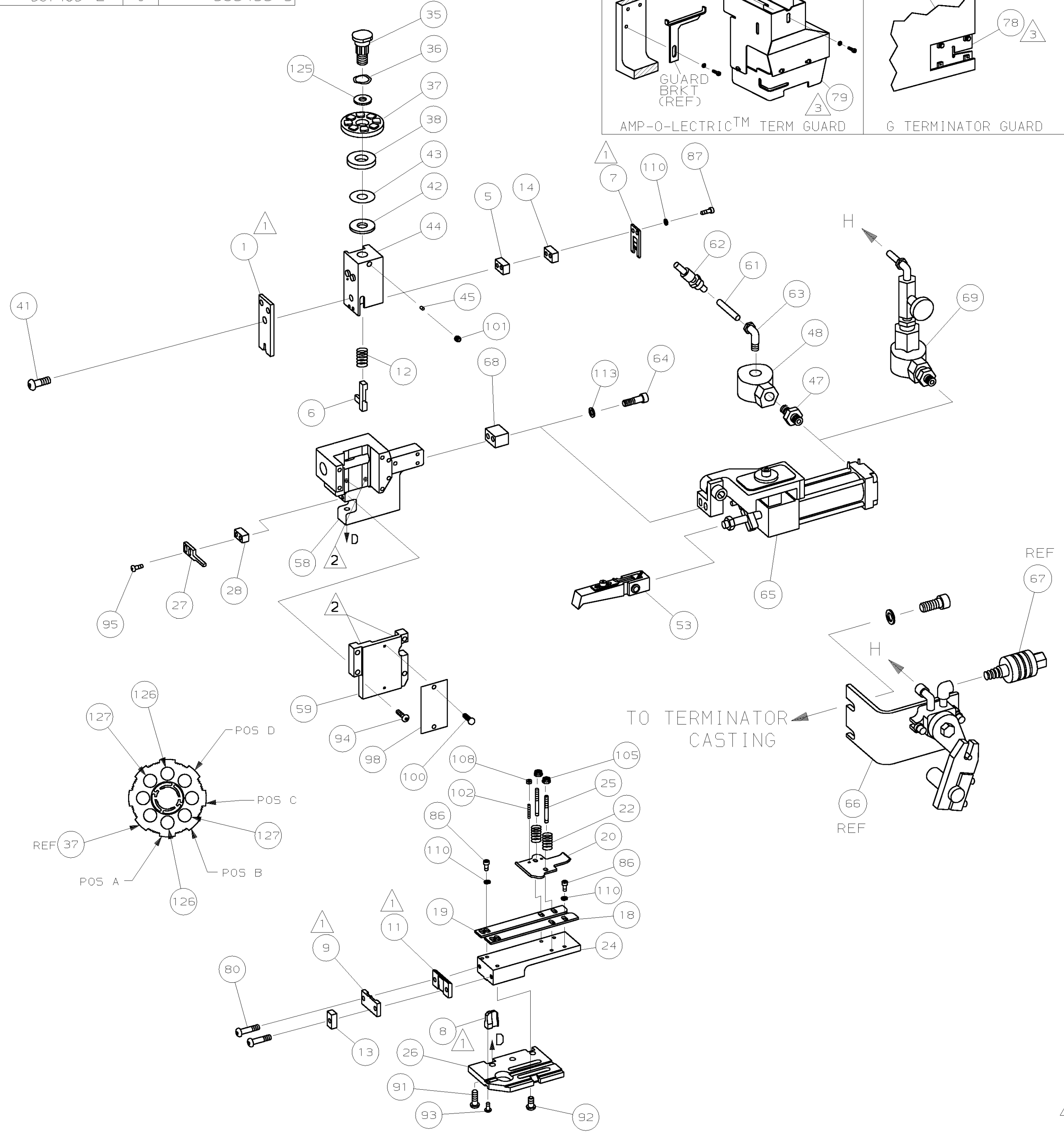

- ① RECOMMENDED SPARE PARTS.
- ② GREASE LIGHTLY.
- ③ GUARD MUST BE IN PLACE WHEN OPERATING APPLICATOR IN A BENCH MACHINE.
- ④ SEE DRAWING FOR COMPONENTS
- ⑤ ITEM 78 USED WITH G TERMINATOR ONLY.

QTY	REV	U/M	DWG SIZE	PART NO	DESCRIPTION	ITEM NO
129						129
128						128
2	2	-	C	1-354779-4	PIN, WIRE DISC (.3060)B	127
2	2	-	C	354779-4	PIN, WIRE DISC (.3010)A	126
1	1	-	A	986950-1	WASHER, FLAT PRECISION	125
1	1	-	A	217238-1	GENERAL INSTRUCTION PACKAGE	124
1	1	-	-	4088039	EF APPL INST 408-8039	123
						122
						121
						120
						119
						118
						117
						116
						115
						114
2	2	-	A	21024-5	WASHER, LOCK (#10) AIR ASSY	113
						112
						111
4	4	-	A	21024-4	WASHER, LOCK (NO.8) SHEAR BL	110
						109
2	2	-	A	21018-4	NUT, HEX (4-40) DRAG	108
						107
						106
2	2	-	A	21022-2	NUT, HEX 5L (8-32) DRAG STUD	105
						104
						103
2	2	-	A	2-21006-6	SCR, SKT SET (4-40x.62) DRAG	102
1	1	-	A	21009-2	SCR, SKT SET (1/4-20x.25) RAM	101
2	2	-	A	21017-2	SCR, DRIVE (#2x.19) ID PLATE	100
						99
1	1	-	B	461264-1	PLATE, IDENTIFICATION	98
						97
						96
2	2	-	A	2-21002-2	SCR, BHC (8-32x.50) STRIPPER	95
4	4	-	A	2-21002-9	SCR, BHC (10-32x.75) CAP	94
1	1	-	A	22733-8	SCR, BHC (8-32x.38 LW) ANVIL	93
4	4	-	A	3-21002-3	SCR, BHC (1/4-20x.50) ST 6D PL	92
3	3	-	A	2-22733-8	SCR, BHC (1/4-20x.62) H5G	91
						90
						89
						88
2	2	-	A	2-21000-9	SCR, SHC (8-32x.75) SLUG BLADE	87
4	4	-	A	2-21000-5	SCR, SHC (8-32x.25) STRIP GUIDE	86
						85
						84
						83
						82
						81
2	2	-	A	3-21002-0	SCR, BHC (10-32x.88) SHEAR PL	80
1	-	-	A	455750-8	GUARD ASSY	79
-	REF	-	A	679532-1	INSERT, GUARD	78
						77
						76
						75
						74
						73
						72
						71

REV	BENCH MODEL	AIR FEED	ITEM NO			
1	-	-	C	692655-5	AIR FEED VALVE ASSY	69
1	1	-	A	461690-1	SPACER, AIR FEED	68
REF	-	-	A	24042-2	VALVE, SHUT OFF	67
REF	-	-	C	692655-6	AIR FEED VALVE ASSY	66
1	1	-	B	2-460277-0	AIR FEED ASSY (2 INCH)	65
2	2	-	A	7-21000-7	SCR, SHC (10-32x2.25) AIR ASSY	64
-	1	-	A	983427-6	ELBOW, SWIVEL 1/8 NPT - 1/4 T	63
-	1	-	A	23238-1	QUICK DISCONNECT	62
-	12.00	IN	A	27319-4	TUBING, POLY-FLO Ø.25	61
						60
1	1	-	C	454220-1	CAP, RAM	59
1	1	-	D	453736-1	HOUSING	58
						57
						56
						55
						54
1	1	-	B	460680-1	FEED FINGER ASSY	53
						52
						51
						50
						49
-	1	-	A	22374-7	VALVE, QUICK EXHAUST	48
-	1	-	A	22304-1	NIPPLE, HEX 1/8 NPT	47
						46
1	1	-	A	690191-1	PLUG, NYLON	45
1	1	-	C	455674-1	RAM	44
1	1	-	A	690125-1	WASHER, LAMINATED	43
1	1	-	A	690124-1	WASHER, RAM	42
1	1	-	A	7-21002-9	BOLT, CRIMPER (5/16-24x1.00)	41
						40
						39
1	1	-	A	690223-2	SPACER, INSULATION DISC	38
1	1	-	D	354777-1	WIRE DISC, PLASTIC	37
1	1	-	A	22480-5	WASHER, SPRING	36
1	1	-	B	690212-1	POST, RAM	35
						34
						33
						32
						31
						30
						29
1	1	-	B	3-690451-2	SPACER, STRIPPER	28
1	1	-	A	240639-1	STRIPPER	27
1	1	-	D	455676-1	PLATE, BASE	26
2	2	-	A	22354-8	DRAG, STUD	25
1	1	-	B	455678-1	PLATE, STRIP GUIDE	24
						23
2	2	-	A	4-22281-1	SPRING, DRAG	22
						21
1	1	-	A	462925-1	DRAG, STOCK	20
1	1	-	B	458030-9	GUIDE, STRIP (REAR)	19
1	1	-	C	458031-9	GUIDE, STRIP (FRONT)	18
						17
						16
						15
1	1	-	C	240641-1	SPACER, SLUG BLADE	14
1	1	-	C	1-690481-0	SPACER, HOLD DOWN	13
1	1	-	A	23846-1	SPRING, HOLD DOWN	12
1	1	-	B	240644-1	PLATE, REAR SHEAR	11
						10
1	1	-	B	690482-1	PLATE, FRONT SHEAR	9
1	1	-	D	1-456537-9	ANVIL	8
1	1	-	B	690474-2	BLADE, SLUG	7
1	1	-	D	455892-3	HOLD DOWN, TERMINAL	6
1	1	-	C	2-240641-7	SPACER, SLUG BLADE	5
						4
						3
						2
1	1	-	C	463223-1	CRIMPER, WIRE	1

THIS DRAWING IS UNPUBLISHED. RELEASED FOR PUBLICATION MAR 23, 1998 BY AMP INCORPORATED. ALL INTERNATIONAL RIGHTS RESERVED. © COPYRIGHT 1998

LOC A
DIST 66

REVISION OF EACH ASSY NO (WHEN BLANK, USE DWG REVISION)

REV	U/M	DWG SIZE	PART NO	DESCRIPTION	ITEM NO
-2	-1				

QTY REOD PER ASSY PARTS LIST

DIMENSIONS IN INCHES. DO NOT SCALE PRINT. TOLERANCES UNLESS OTHERWISE SPECIFIED:
 2 PLC DEC ±.25
 3 PLC DEC ±.
 4 PLC DEC ±.
 ANGLES ±.
 SURF TEXTURE: ✓
 REMOVE BURRS, BREAK SHARP EDGES R.015 MAX

MATL - HT TR - FIN -

DR M. OBRINE 19JUN96 APP T. ELBIN 6-19-96
 CHK 6-19-96 REL 7/16/96
 C. ERISMAN B. MORGAN

AMP AMP Incorporated Harrisburg, PA 17105-3608

NAME END FEED HDM APPLICATOR MACHINE REF MINI APPL
 SCALE - DWG NO 567469 SHEET 1 OF 1 REV C1

CAGE CODE 00779 CUSTOMER AND ASSEMBLY DRAWING RESTRICTED TO