

REV
NC HD10-9-1939P*-P080

REVISIONS			
SYM	DESCRIPTION	DATE	APPROVED
NC	NEW RELEASE PER E.O. P21126	11-8-11	RDR

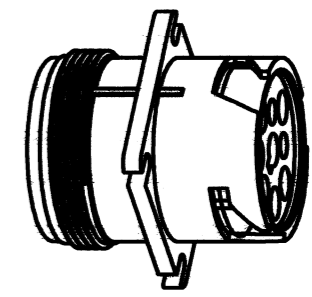
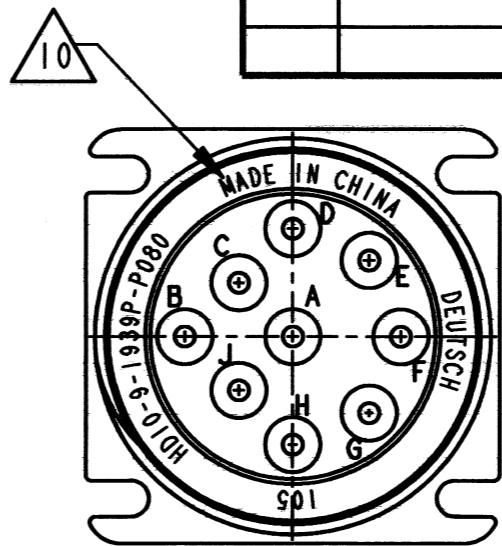

3D VIEW

10. COUNTRY OF ORIGIN IF OTHER THAN USA. EXAMPLE: MADE IN CHINA.

9. WHEN *= E: IDENTIFIES 'E' WIRE SEAL.
WHEN *= BLANK: IDENTIFIES 'NORMAL' WIRE SEAL.

8. MATERIAL: SHELL: PLASTIC, SEAL: RUBBER.

7. OVERALL DIMENSION DOES NOT INCLUDE RUBBER GROMMET.

6. THIS RECEPTACLE MATES WITH HD16-9-1939S*-P080 AND HD17-9-1939S*-P080 PLUGS (*=SEAL TYPE).

5. FOR "PERFORMANCE AND APPLICATION CHARACTERISTICS OF SOLID/STAMPED AND FORMED CONTACTS AND WIRES," SEE ENVELOPE DRAWING 0425-015-0000. THIS RECEPTACLE USES PIN CONTACTS ONLY.

4. RECOMMENDED PANEL THICKNESS: .062 [1.57] TO .188 [4.77].

3. ALL DIMENSIONS ARE IN INCHES [MILLIMETERS].
DIMENSION TOLERANCE $\pm .025$ [.63] UNLESS OTHERWISE NOTED.

2. THIS CONNECTOR SERIES WILL ACCOMMODATE THE FOLLOWING WIRE INSULATION DIAMETERS:

SEAL TYPE	CONTACT SIZE	MIN. INSUL. O.D.	MAX. INSUL. O.D.	WIRE RANGE [mm ²]
NORMAL	16	.100 [2.54]	.150 [3.81]	14-20 AWG [2.0-.50]
E	16	.053 [1.35]	.120 [3.05]	14-20 AWG [2.0-.50]

1. CONSULT FACTORY FOR ELECTRICAL AND MATERIAL SPECIFICATIONS.

NOTES:

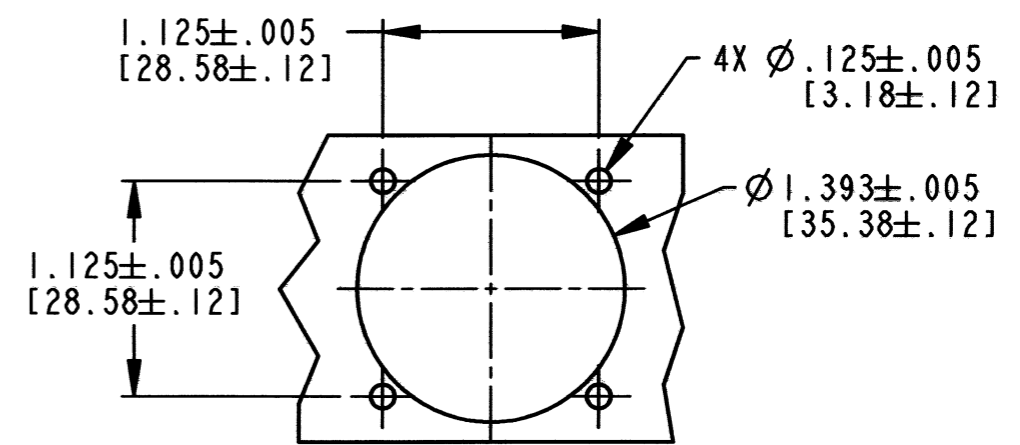

RECOMMENDED PANEL CUTOUT 4

SIGNATURE & DATE	
DR	I. GRANTCHAROVA 8/10/11
CHK	[Signature] 11/08/2011
PE	[Signature] 10/20/11
APPD	[Signature]
SCALE	NONE WT

RECEPTACLE CONNECTOR
SQUARE FLANGE
ARR. 9-1939
-P08 MOD
HD10 SERIES
ENVELOPE

EP	MATL. CODE
3850 INDUSTRIAL AVE. HEMET, CA 92545 DEUTSCH INDUSTRIAL	
B HD10-9-1939P*-P080	
DWG SIZE	CODE 11139 SHEET OF