

【1. 適用範囲 SCOPE】

本仕様書は、_____ 殿 に納入する
 0.5mm ピッチ FFC 対 基板 用 コネクタ について規定する。
 This specification covers the 0.5mm PITCH FFC TO BOARD CONNECTOR series.

【2. 製品名称及び型番 PRODUCT NAME AND PART NUMBER】

製品名称 Product Name		製品型番 Material Number
コネクタ側 Connector Side	ハウジングアッセンブリ Housing Assembly (ST Type)	501786-**41
	501786-**41 テーピング梱包 Embossed Tape Package for 501786-**41	501786-**92
	ハウジングアッセンブリ グランド端子付き Housing Assembly with Ground(ST Type)	501786-**31
	ハウジングアッセンブリ グランド端子付き Housing Assembly with Ground(ST Type)	501786-**61
	501786-**31, -**61 テーピング梱包 Embossed Tape Package for 501786-**31, -**61	501786-**91
プラグ側 Plug Side	プラグジャケット(小ラッチ) Plug Jacket (Small Latch)	501783-***9
	プラグジャケットカバー(小ラッチ) Plug Jacket Cover (Small Latch)	501784-****
	プラグジャケット(大ラッチ) Plug Jacket (Large Latch)	503150-**09
	プラグジャケットカバー(大ラッチ) Plug Jacket Cover (Large Latch)	503151-**09

* : 図面参照 Refer to the drawings.

・ ジャケット、ジャケットカバー対応表 CORRESPONDENCE TABLE

製品名称(テーピング梱包) Product Name(Embossed Tape Package)	プラグジャケット Plug Jacket	プラグジャケットカバー Plug Jacket Cover
501786-3092	501783-3009	501784-3009
501786-3091	501783-3009	501784-3008
501786-5091	503150-5009	503151-5009

REV.	A	B	C	D	E			
SHEET	1~16	1~17	1~17	1~17	1~18			
REVISE ON PC ONLY					TITLE:			
E	改訂 REVISED J2015-1471 2015/08/11 M.TAKAHASHI04				0.5 mm PITCH FFC TO BOARD CONNECTOR			
					製品仕様書			
THIS DOCUMENT CONTAINS INFORMATION THAT IS PROPRIETARY TO MOLEX INC. AND SHOULD NOT BE USED WITHOUT WRITTEN PERMISSION								
REV.	DESCRIPTION				WRITTEN BY:	CHECKED BY:	APPROVED BY:	DATE: YR/MO/DAY
	DESIGN CONTROL		STATUS		M.TAKASAKI	M.HAYASHI	N.UKITA	2009/01/30
DOCUMENT NUMBER							FILE NAME	SHEET
PS-501786-004							PS501786004.docx	1 OF 18
EN-037(2013-04 rev.1)								

【 3. 定格 RATINGS 】

項目 Item	規格 Standard	
最大許容電圧 Rated Voltage (MAX.)	50 V ^{*2}	[AC (実効値 rms) /DC]
最大許容電流 Rated Current (MAX.)	0.5 A ^{*2}	
使用温度範囲 Ambient Temperature Range (Operating and Non-operating)	-40°C ~ +105°C ^{*1*2*3}	

*1 : 通電による温度上昇分を含む。

Including terminal temperature rise.

*2 : 使用FFCも本定格を満足すること。

FFC must be met ratings specified in this standard.

*3 : 8-4を参照のこと。

See for details 8-4

【 4. 性能 PERFORMANCE 】

4-1. 電気的性能 Electrical Performance

項目 Item	条件 Test Condition	規格 Requirement
4-1-1 接触抵抗 Contact Resistance	適合FFCハーネスを嵌合させ、開放電圧 20mV 以下、短絡電流 10mA 以下にて測定する。 (JIS C5402 5.4) Mate applicable FFC Harness, measure by dry circuit, 20mV MAX., 10mA MAX. (JIS C5402 5.4)	40 milliohm MAX.
4-1-2 絶縁抵抗 Insulation Resistance	適合FFCハーネスを嵌合させ、隣接するターミナル間及びターミナル、アース間に、DC 500V を印加し測定する。 (JIS C5402 5.2/MIL-STD-202 試験法 302) Mate applicable FFC Harness and apply 500V DC between adjacent terminal and ground. (JIS C5402 5.2/MIL-STD-202 Method 302)	50 Megohm MIN.

REVISE ON PC ONLY

E

SEE SHEET 1 OF 18

TITLE:

0.5 mm PITCH FFC TO BOARD CONNECTOR

製品仕様書

THIS DOCUMENT CONTAINS INFORMATION THAT IS PROPRIETARY TO MOLEX INC. AND SHOULD NOT BE USED WITHOUT WRITTEN PERMISSION

REV.

DESCRIPTION

DOCUMENT NUMBER

PS-501786-004

FILE NAME

PS501786004.docx

SHEET

2 OF 18

項目 Item	条件 Test Condition	規格 Requirement
4-1-3 耐電圧 Dielectric Strength	適合FFCハーネスを嵌合させ、隣接するターミナル間及びターミナル、アース間に、AC 250V（実効値）を1分間印加する。 (JIS C5402 5.1/MIL-STD-202 試験法 301) Mate applicable FFC Harness, apply 250V AC (rms) for 1 minute between adjacent terminal or ground. (JIS C5402 5.1/MIL-STD-202 Method 301)	異状なきこと No Breakdown

4-2. 機械的性能 Mechanical Performance

項目 Item	条件 Test Condition	規格 Requirement
4-2-1 挿入・抜去力 Insertion Force/ Withdrawal Force	ロックを解除した状態にて、毎分 25±3 mm の速さで挿入・抜去を行う。 Insert and withdraw connectors, at the speed rate of 25±3 mm per minute.	第6項参照 Refer to paragraph 6
4-2-2 端子保持力 Terminal / Housing Retention Force	各端子を軸方向に、毎分 25±3mm の速さで引張る。 Apply axial pull out force at a rate of 25±3mm/minute on the terminal assembled in the housing.	0.5N {0.05kgf} MIN.
4-2-3 金具保持力 Fitting Nail / Housing Retention Force	各金具を軸方向に、毎分 25±3mm の速さで引張る。 Apply axial pull out force at a rate of 25±3mm/minute on the Fitting Nail assembled in the housing.	1.0N {0.10kgf} MIN.
4-2-4 強制抜去力 Compulsion Withdrawal Force	適合FFCハーネスを嵌合させ、ロックを解除せずに毎分 25±3 mm の速さで軸方向にを引き抜く。 Mate applicable FFC Harness, apply axial pull out force at the speed rate of 25±3 mm per minute.	9.8 N{ 1.0 kgf} MINIMUM

REVISE ON PC ONLY

E

SEE SHEET 1 OF 18

TITLE:

0.5 mm PITCH FFC TO BOARD CONNECTOR

製品仕様書

THIS DOCUMENT CONTAINS INFORMATION THAT IS PROPRIETARY TO MOLEX INC. AND SHOULD NOT BE USED WITHOUT WRITTEN PERMISSION

REV.

DESCRIPTION

DOCUMENT NUMBER
PS-501786-004

FILE NAME

PS501786004.docx

SHEET

3 OF 18

4-3. その他 Environmental Performance and Others

項目 Item		条件 Test Condition	規格 Requirement	
4-3-1	繰り返し挿抜 Repeated Mate / Un-matel	無通電状態にて、1分間に 10回以下の速さ で挿入、抜去を 20回 繰り返す。 When mated up to 20 cycles repeatedly at the speed rate of less than 10 cycles per minute.	接触抵抗 Contact Resistance	60 milliohm MAX.
4-3-2	温度上昇 Temperature Rise	適合FFCハーネスを嵌合させ、最大許容電流を 通電し、コネクタの温度上昇分を測定する。 (UL 498) Carrying rated current load. (UL 498)	温度上昇 Temperature Rise	30 °C MAX.
4-3-3	耐振動性 Vibration	DC 1mA 通電状態にて、嵌合軸を含む互いに 垂直な 3方向 に掃引割合 10~55~10Hz/分、 全振幅 1.5mm の振動を 各2時間 加える。 (MIL-STD-202試験法 201) Amplitude : 1.5 mm P-P Sweep time : 10-55-10 Hz in 1 minutes Duration : 2 hours in each X.Y.Z axes (MIL-STD-202, Method 201)	外観 Appearance	異常なきこと No Damage
			接触抵抗 Contact Resistance	60 milliohm MAX.
			瞬断 Discontinuity	1 microsecond MAX
4-3-4	耐衝撃性 Shock	DC 1mA 通電状態にて、嵌合軸を含む互いに 垂直な 6方向 に 490m/s ² {50G} の衝撃を 各3回 加える。 (JIS C 60068-2-27 / MIL-STD-202試験法 213) 490m/s ² {50 G}, 3 strokes in each X.Y.Z. axes. (JIS C 60068-2-27/MIL-STD-202 Method 213)	外観 Appearance	異常なきこと No Damage
			接触抵抗 Contact Resistance	60 milliohm MAX.
			瞬断 Discontinuity	1 microsecond MAX.
4-3-5	耐熱性 Heat Resistance	適合FFCハーネスを嵌合させ、105±2°C の 雰囲気中に96時間 放置後取り出し、1~2時間 室温に放置する。 (JIS C 60068-2-2/MIL-STD-202 試験法 108) 105±2°C, 96 hours (JIS C 60068-2-2/MIL-STD-202 Method 108)	外観 Appearance	異常なきこと No Damage
			接触抵抗 Contact Resistance	60 milliohm MAX.

REVISE ON PC ONLY

E

SEE SHEET 1 OF 18

TITLE:

0.5 mm PITCH FFC TO BOARD CONNECTOR

製品仕様書

THIS DOCUMENT CONTAINS INFORMATION THAT IS PROPRIETARY TO
MOLEX INC. AND SHOULD NOT BE USED WITHOUT WRITTEN PERMISSION

REV.

DESCRIPTION

DOCUMENT NUMBER
PS-501786-004

FILE NAME

PS501786004.docx

SHEET

4 OF 18

項目 Item		条件 Test Condition	規格 Requirement	
4-3-6	耐寒性 Cold Resistance	適合FFCハーネスを嵌合させ、-40±2℃ の 雰囲気中に96時間 放置後取り出し、1~2時間 室温に放置する。 (JIS C 60068-2-1) -40±2℃, 96 hours (JIS C 60068-2-1)	外観 Appearance	異常なきこと No Damage
			接触抵抗 Contact Resistance	60 milliohm MAX.
4-3-7	耐湿性 Humidity	適合FFCハーネスを嵌合させ、60±2℃ 相対 湿度 90~95% の雰囲気中に 96時間 放置後 取り出し、1~2時間 室温に放置する。 (JIS C 60068-2-3/MIL-STD-202 試験方法103) Temperature: 60±2℃ Relative Humidity: 90~95% Duration: 96 hours (JIS C 60068-2-3/MIL-STD-202 Method 103)	外観 Appearance	異常なきこと No Damage
			接触抵抗 Contact Resistance	60 milliohm MAX.
			耐電圧 Dielectric Strength	4-1-3項満足のこと Must meet 4-1-3
			絶縁抵抗 Insulation Resistance	20 Megohm MIN.
4-3-8	温度サイクル Temperature Cycling	適合FFCハーネスを嵌合させ、-40±3℃に30分、 +105±2℃ に 30分、これを 1サイクル とし、 5サイクル 繰り返す。 但し、温度移行時間は 5分以内 とする。 試験後 1~2時間 室温に放置する。 (JIS C60068) 5 cycles of : a) -40±3℃ 30minutes b) +105±2℃ 30minutes (JIS C60068)	外観 Appearance	異常なきこと No Damage
			接触抵抗 Contact Resistance	60 milliohm MAX.

REVISE ON PC ONLY

E

SEE SHEET 1 OF 18

TITLE:

0.5 mm PITCH FFC TO BOARD CONNECTOR

製品仕様書

THIS DOCUMENT CONTAINS INFORMATION THAT IS PROPRIETARY TO MOLEX INC. AND SHOULD NOT BE USED WITHOUT WRITTEN PERMISSION

REV.

DESCRIPTION

DOCUMENT NUMBER
PS-501786-004

FILE NAME

PS501786004.docx

SHEET

5 OF 18

項目 Item		条件 Test Condition	規格 Requirement	
4-3-9	亜硫酸ガス SO ₂ Gas	適合FFCハーネスを嵌合させ、40±2°C にて 50±5ppmの亜硫酸ガス中に 24時間放置する。 24 hours exposure to 50±5ppm. SO ₂ gas at 40±2°C	接触抵抗 Contact Resistance	60 milliohm MAX.
4-3-10	耐アンモニア性 NH ₃ Gas	適合FFCハーネスを嵌合させ、濃度 28% の アンモニア水を入れた容器中に 40分間 放置 する。 (1Lに対して25mLの割合) 40 minutes exposure to NH ₃ gas evaporating from 28% Ammonia solution.	接触抵抗 Contact Resistance	60 milliohm MAX.
4-3-11	半田付け性 Solder Ability	端子先端より 0.3mm、金具先端より 0.3mm の位置まで、245±3°C の半田に 3±0.5秒 浸 す。 Soldering Time : 3±0.5 seconds Solder Temperature : 245±3°C 0.3mm from terminal tip. 0.3mm from fitting nail tip.	濡れ性 Solder Wetting	浸漬面積の 75%以上 75% of immersed area must show no voids, pin holes.
4-3-12	半田耐熱性 Resistance to Soldering Heat	(リフロー時) 第7項参照。 (When reflowing) Refer to paragraph 7.	外 観 Appearance	端子ガタ、 割れ等 異状無き事 No Damage
		(手半田) 端子先端より 0.3mm、金具先端より 0.3mm の位置まで 350±10°C の半田ゴテにて 3秒 加熱する。 (Soldering iron method) Solder time : 3 seconds Solder temperature : 350±10°C 0.3mm from terminal tip. 0.3mm from fitting nail tip.		

() : 参考規格 Reference Standard
{ } : 参考単位 Reference Unit

【5. 外観形状、寸法及び材質 PRODUCT SHAPE, DIMENSIONS AND MATERIALS】

図面参照 Refer to the drawing.

REVISE ON PC ONLY		TITLE: 0.5 mm PITCH FFC TO BOARD CONNECTOR 製品仕様書
E	SEE SHEET 1 OF 18	
REV.	DESCRIPTION	THIS DOCUMENT CONTAINS INFORMATION THAT IS PROPRIETARY TO MOLEX INC. AND SHOULD NOT BE USED WITHOUT WRITTEN PERMISSION
DOCUMENT NUMBER PS-501786-004		FILE NAME PS501786004.docx
		SHEET 6 OF 18

【6. 挿入・抜去力 INSERTION FORCE/WITHDRAWAL FORCE】

下記の F F C を使用した場合のテストデータ (参考)
This test data in case of used the following FFC (Reference)

F F C : 住友電気工業株式会社 製
FFC : SUMITOMO ELECTRIC INDUSTRIES, LTD.
厚さ (導体部) : 0.305 ~ 0.310 mm
Thickness (CONDUCTOR AREA) : 0.305 ~ 0.310 mm

<501786-**41>

(N=5)

極数 No.	of CKT	単位 UNIT	挿入力 Retention Force			抜去力 Withdrawal Force		
			平均値 AVG.	最大値 MAX.	最小値 MIN.	平均値 AVG.	最大値 MAX.	最小値 MIN.
30	初回 1st	N {kgf}	9.86 {1.01}	10.7 {1.09}	9.0 {0.92}	6.30 {0.64}	6.6 {0.67}	5.8 {0.59}
	10回目 10th	N {kgf}	8.40 {0.86}	8.7 {0.89}	8.2 {0.84}	5.04 {0.51}	5.3 {0.54}	4.4 {0.45}
	20回目 20th	N {kgf}	8.54 {0.87}	8.7 {0.89}	8.4 {0.86}	5.10 {0.52}	5.6 {0.57}	4.5 {0.46}

<501786-**31>

(N=5)

極数 No.	of CKT	単位 UNIT	挿入力 Retention Force			抜去力 Withdrawal Force		
			平均値 AVG.	最大値 MAX.	最小値 MIN.	平均値 AVG.	最大値 MAX.	最小値 MIN.
30	初回 1st	N {kgf}	13.28 {1.36}	14.0 {1.43}	12.4 {1.27}	7.78 {0.79}	8.1 {0.83}	7.3 {0.74}
	10回目 10th	N {kgf}	12.10 {1.23}	13.4 {1.37}	10.7 {1.09}	6.72 {0.69}	7.5 {0.77}	6.4 {0.65}
	20回目 20th	N {kgf}	12.00 {1.22}	12.9 {1.32}	10.8 {1.10}	6.68 {0.68}	7.1 {0.72}	6.5 {0.66}

REVISE ON PC ONLY

E

SEE SHEET 1 OF 18

TITLE:

0.5 mm PITCH FFC TO BOARD CONNECTOR

製品仕様書

THIS DOCUMENT CONTAINS INFORMATION THAT IS PROPRIETARY TO MOLEX INC. AND SHOULD NOT BE USED WITHOUT WRITTEN PERMISSION

REV.

DESCRIPTION

DOCUMENT NUMBER
PS-501786-004

FILE NAME

PS501786004.docx

SHEET

7 OF 18

<501786-**61>

(N=5)

極数 No.	of CKT	単位 UNIT	挿入力 Retention Force			抜去力 Withdrawal Force		
			平均値 AVG.	最大値 MAX.	最小値 MIN.	平均値 AVG.	最大値 MAX.	最小値 MIN.
50	初回 1st	N {kgf}	20.68 {2.11}	22.2 {2.27}	19.5 {1.99}	10.40 {1.06}	11.1 {1.13}	9.9 {1.01}
	10回目 10th	N {kgf}	19.06 {1.94}	20.2 {2.06}	18.3 {1.87}	8.66 {0.88}	9.0 {0.92}	8.2 {0.84}
	20回目 20th	N {kgf}	18.38 {1.87}	19.7 {2.01}	17.6 {1.80}	8.42 {0.86}	8.9 {0.91}	8.1 {0.83}

* FFCの仕様により影響を受ける為、規格を満たさない事があります。

There may be the case which the connector performance does not meet the above specification, because the different FFC manufacturers have their own unique specification.

REVISE ON PC ONLY		TITLE: 0.5 mm PITCH FFC TO BOARD CONNECTOR 製品仕様書
E	SEE SHEET 1 OF 18	
REV.	DESCRIPTION	THIS DOCUMENT CONTAINS INFORMATION THAT IS PROPRIETARY TO MOLEX INC. AND SHOULD NOT BE USED WITHOUT WRITTEN PERMISSION
DOCUMENT NUMBER PS-501786-004		FILE NAME PS501786004.docx
		SHEET 8 OF 18

【7. 赤外線リフロー条件 INFRARED REFLOW CONDITION】

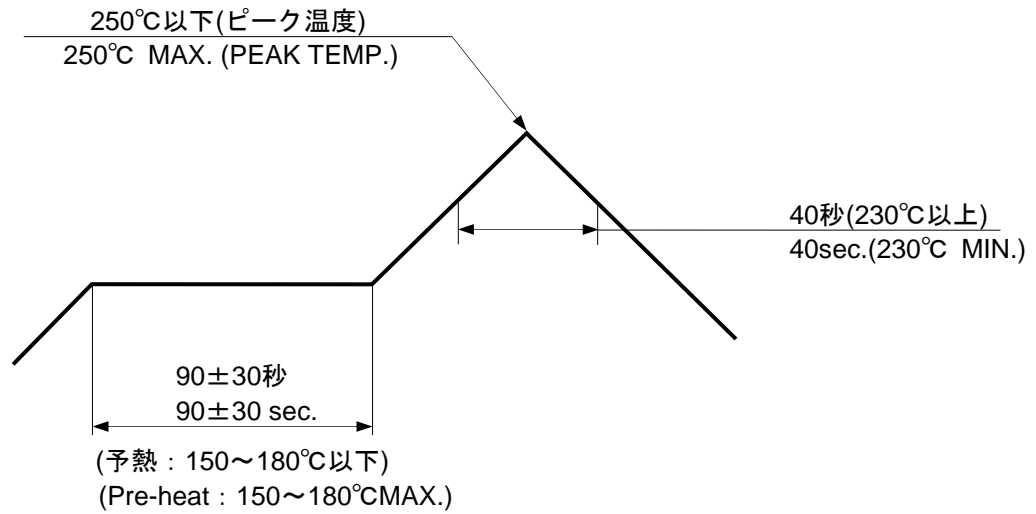

温度条件グラフ
(温度は基板パターン面)

TEMPERATURE CONDITION GRAPH
(TEMPERATURE ON THE SURFACE OF P.C.BOARD PATTERN)

注記 ; 本リフロー条件に関しては、リフロー装置及び基板などにより条件が異なりますので、事前にリフロー評価の確認をお願い致します。

NOTE ; Please check the reflow soldering condition by your own devices beforehand. Because the condition changes by the soldering devices, P.C.Boards, and so on.

REVISE ON PC ONLY		TITLE: 0.5 mm PITCH FFC TO BOARD CONNECTOR 製品仕様書
E	SEE SHEET 1 OF 18	
REV.	DESCRIPTION	THIS DOCUMENT CONTAINS INFORMATION THAT IS PROPRIETARY TO MOLEX INC. AND SHOULD NOT BE USED WITHOUT WRITTEN PERMISSION
DOCUMENT NUMBER PS-501786-004		FILE NAME PS501786004.docx
		SHEET 9 OF 18
EN-037(2013-04 rev.1)		

【 8. 取り扱い説明書 INSTRUCTION FOR THE HANDLING OF THE CONNECTOR】
 8-1. 各部の名称 DESCRIPTION OF EACH PART

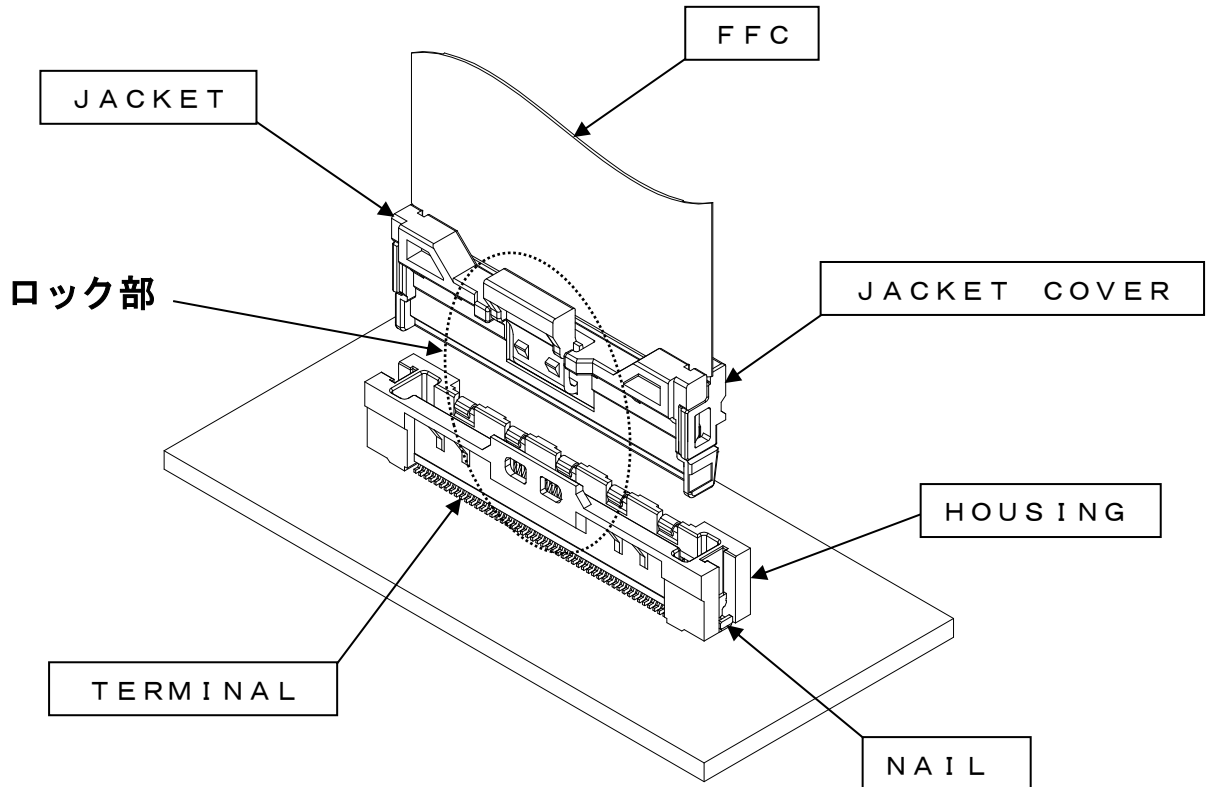

8-2. 基板への実装に関して MOUNTING ON THE PC BOARD

基板への実装は実装機にて実施願います。もし、手半田する場合は、TERMINAL及びNAIL等に
 触れない様に願います。（半田付け不良等の原因となる可能性が有ります。）

The mounting of the PC board is handled by the mounter. If to manually solder, please be cautious to not
 touch the Terminal and Fitting Nail.(It will create the possibility to cause solderbility failure.)

REVISE ON PC ONLY		TITLE: 0.5 mm PITCH FFC TO BOARD CONNECTOR	
E	SEE SHEET 1 OF 18	製品仕様書	
REV.	DESCRIPTION	THIS DOCUMENT CONTAINS INFORMATION THAT IS PROPRIETARY TO MOLEX INC. AND SHOULD NOT BE USED WITHOUT WRITTEN PERMISSION	
DOCUMENT NUMBER PS-501786-004		FILE NAME PS501786004.docx	SHEET 10 OF 18
EN-037(2013-04 rev.1)			

8-3. コネクタ嵌合に関して MATING THE CONNECTOR

コネクタを嵌合する際は、JACKETとJACKET COVERの全体もしくは中央を掴んで挿入を実施ください。

When mating the connector, hold the JACKET AND JACKET COVER together at either a whole or the center portion of them to insert.

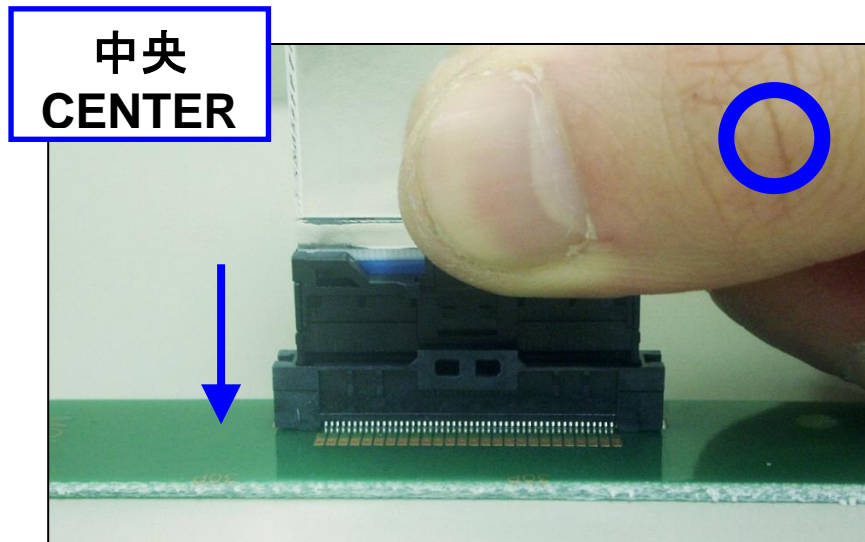
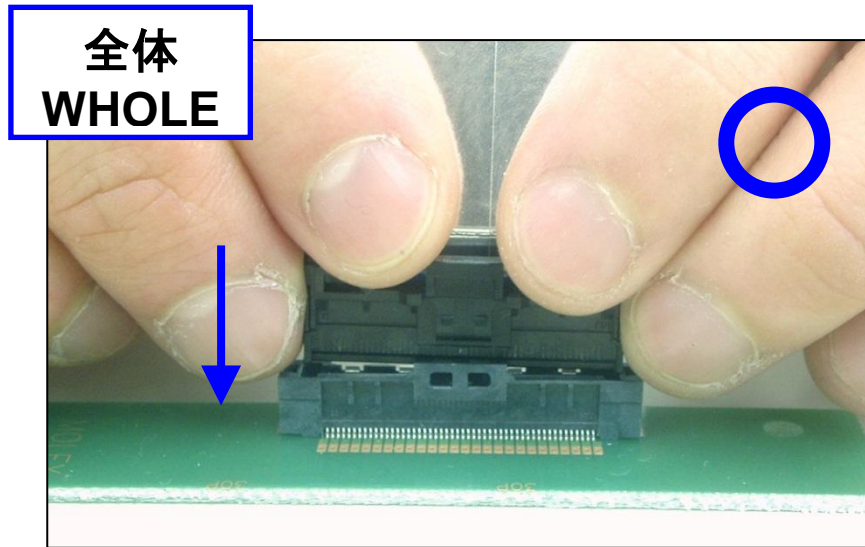

REVISE ON PC ONLY		TITLE: 0.5 mm PITCH FFC TO BOARD CONNECTOR <p style="text-align: right;">製品仕様書</p>	
E	SEE SHEET 1 OF 18		
REV.	DESCRIPTION	THIS DOCUMENT CONTAINS INFORMATION THAT IS PROPRIETARY TO MOLEX INC. AND SHOULD NOT BE USED WITHOUT WRITTEN PERMISSION	
DOCUMENT NUMBER PS-501786-004		FILE NAME PS501786004.docx	SHEET 11 OF 18
EN-037(2013-04 rev.1)			

以下のような嵌合は回復不可能な機能不全や製品破壊につながりますので実施しないで下さい。
 The following method of mating will cause either irreversable functionality failure or product breaking, so please do not mate this way.

- ・ F F Cのみを掴まないでください。
 Please do not hold the FFC part only

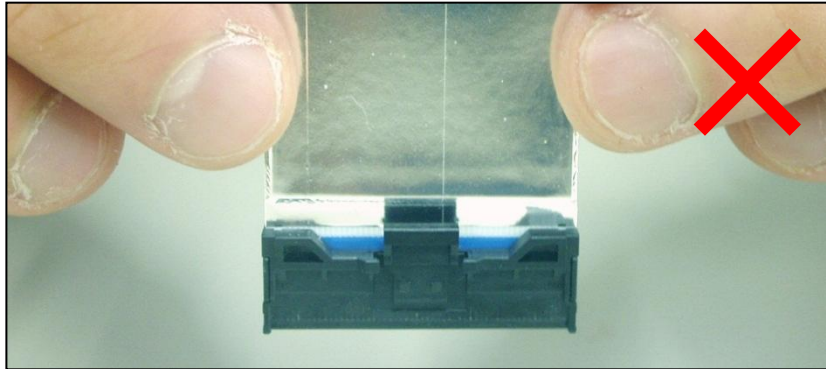

- ・ J A C K E T と J A C K E T C O V E R の 端部のみを掴まないでください。
 Please do not hold the JACKET AND edge of the JACKET COVER only

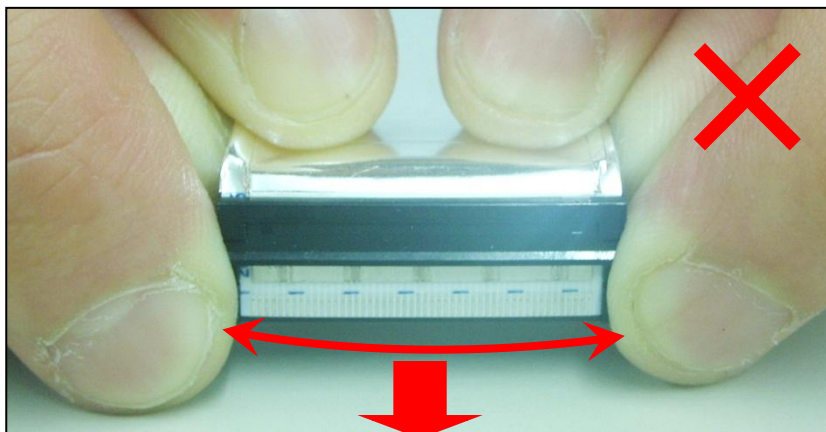

REVISE ON PC ONLY		TITLE:	
E	SEE SHEET 1 OF 18	0.5 mm PITCH FFC TO BOARD CONNECTOR	
		製品仕様書	
REV.	DESCRIPTION	THIS DOCUMENT CONTAINS INFORMATION THAT IS PROPRIETARY TO MOLEX INC. AND SHOULD NOT BE USED WITHOUT WRITTEN PERMISSION	
DOCUMENT NUMBER PS-501786-004		FILE NAME PS501786004.docx	SHEET 12 OF 18
EN-037(2013-04 rev.1)			

- ・ F F C を折り曲げるように掴まないでください。
Please do not hold the FFC like bending it.

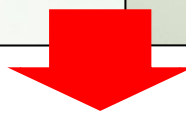
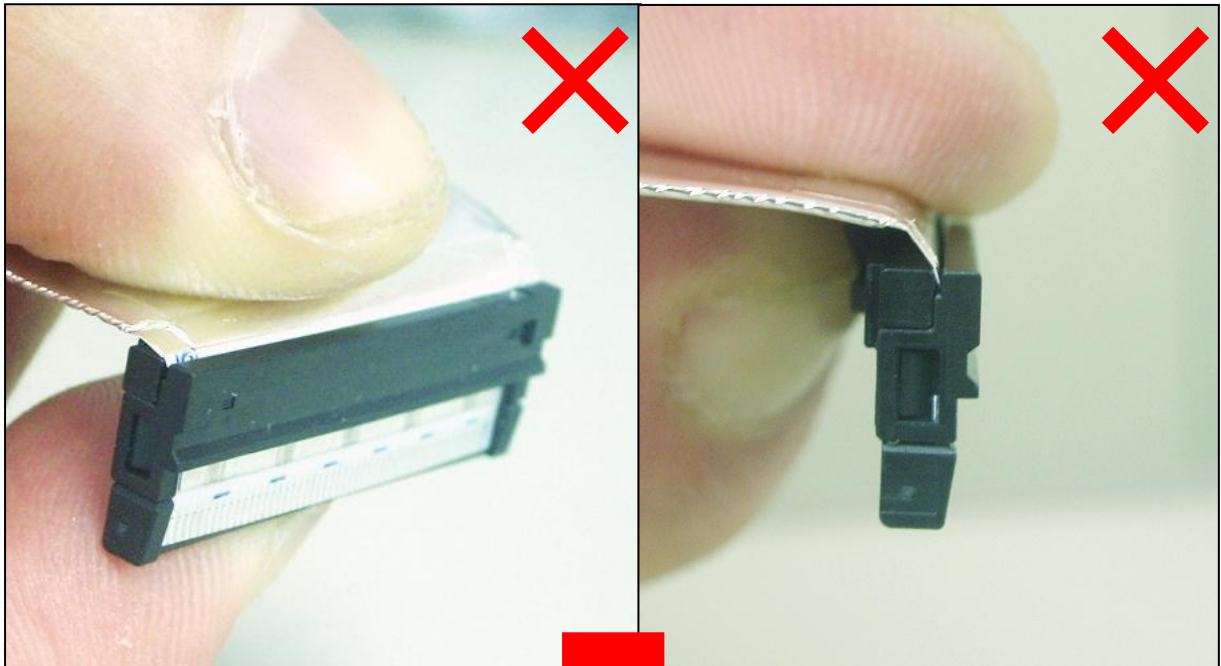

REVISE ON PC ONLY		TITLE:	
E	SEE SHEET 1 OF 18	0.5 mm PITCH FFC TO BOARD CONNECTOR	
		製品仕様書	
REV.	DESCRIPTION	THIS DOCUMENT CONTAINS INFORMATION THAT IS PROPRIETARY TO MOLEX INC. AND SHOULD NOT BE USED WITHOUT WRITTEN PERMISSION	
DOCUMENT NUMBER PS-501786-004		FILE NAME PS501786004.docx	SHEET 13 OF 18
EN-037(2013-04 rev.1)			

- ※ FFCが極端に浮くと、嵌合時にHOUSINGと干渉し座屈する可能性があります。
- ※ If FFC warps too much, it will touch with the Header housing when mated, And may possibly cause buckling.

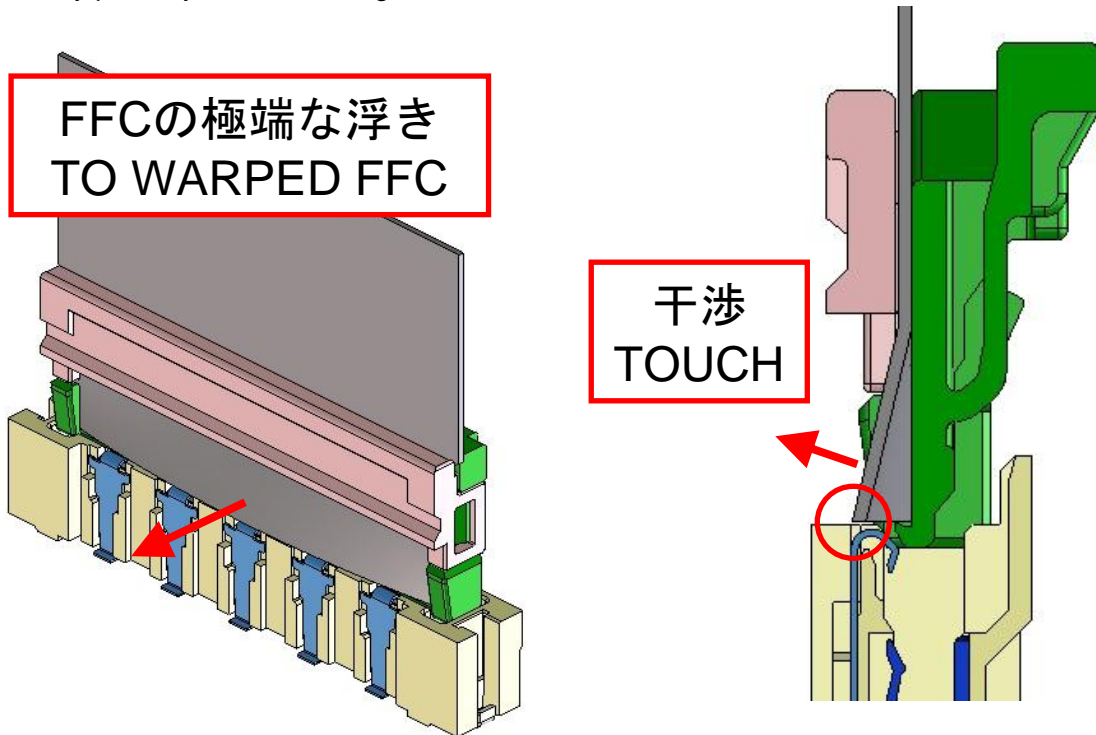

- ・ JACKETとJACKET COVERの片端のみを掴まないでください。斜め嵌合となり、不良につながります。 Please do not hold one side of the JACKET and the JACKET COVER only as shown below. It will be mated in the slant direction and will cause failure

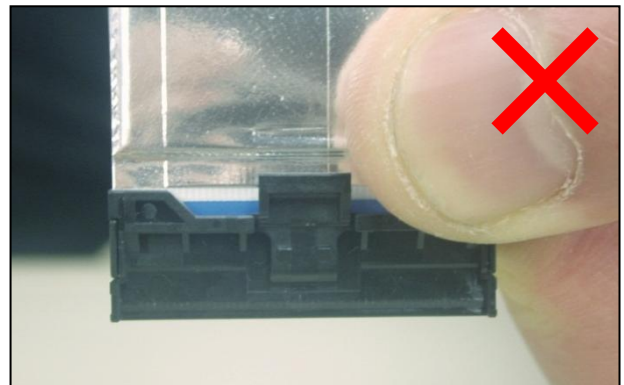
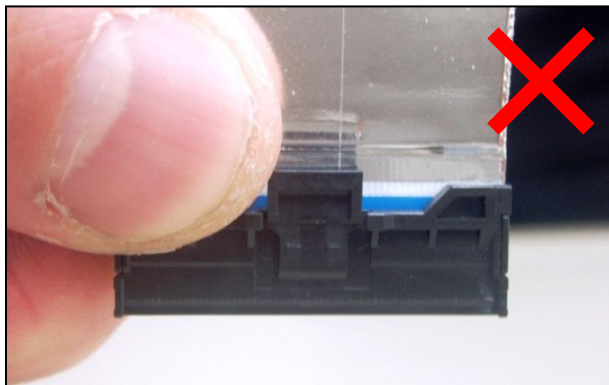

REVISE ON PC ONLY		TITLE: 0.5 mm PITCH FFC TO BOARD CONNECTOR	
E	SEE SHEET 1 OF 18	製品仕様書	
REV.	DESCRIPTION	THIS DOCUMENT CONTAINS INFORMATION THAT IS PROPRIETARY TO MOLEX INC. AND SHOULD NOT BE USED WITHOUT WRITTEN PERMISSION	
DOCUMENT NUMBER PS-501786-004		FILE NAME PS501786004.docx	SHEET 14 OF 18
EN-037(2013-04 rev.1)			

- ・斜め嵌合は不良につながりますので実施しないでください。
Mating inconsistently will cause failure, so please do not do this.

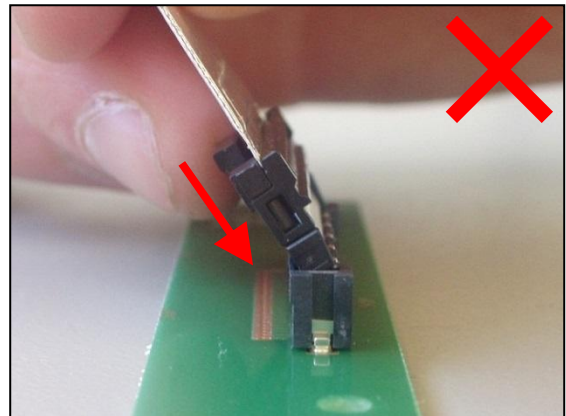
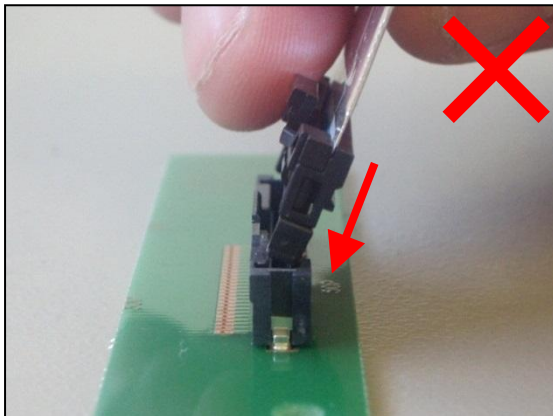
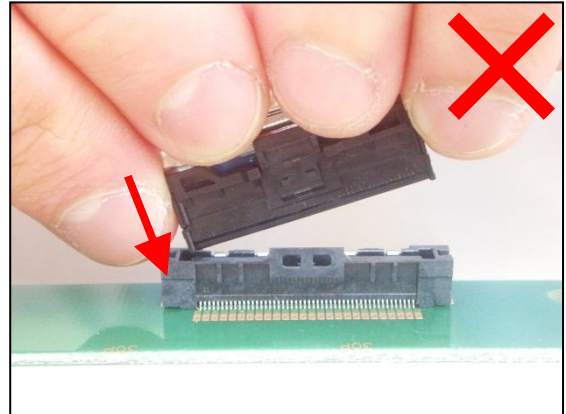
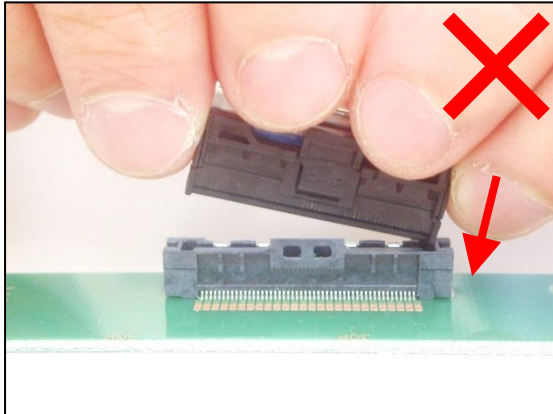

- ・嵌合状態 及び 嵌合時の F F C 引き回し作業においてロック部に無理な負荷が掛かるような使用は避けてください。
Please be cautious not to put excess load at the lock part after mating and when FFC is pulled and extracted.

REVISE ON PC ONLY		TITLE:	
E	SEE SHEET 1 OF 18	0.5 mm PITCH FFC TO BOARD CONNECTOR	
	REV. DESCRIPTION	製品仕様書	
		THIS DOCUMENT CONTAINS INFORMATION THAT IS PROPRIETARY TO MOLEX INC. AND SHOULD NOT BE USED WITHOUT WRITTEN PERMISSION	
DOCUMENT NUMBER PS-501786-004		FILE NAME PS501786004.docx	SHEET 15 OF 18
EN-037(2013-04 rev.1)			

- ・コネクタの嵌合を取り外す際は、必ずロック解除して実施ください。
Please be sure to release the lock when unmating the connector.

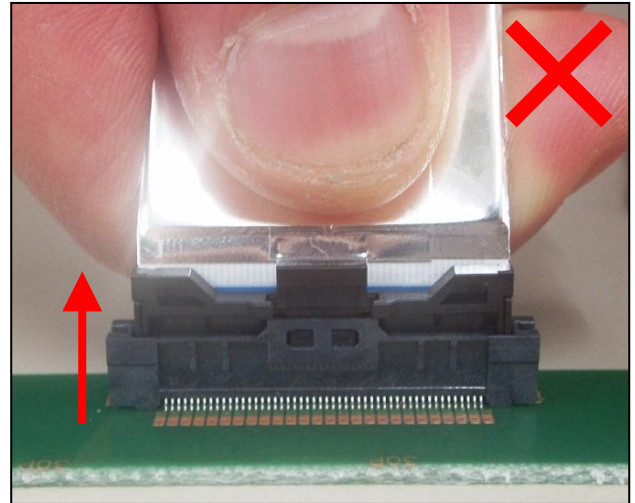
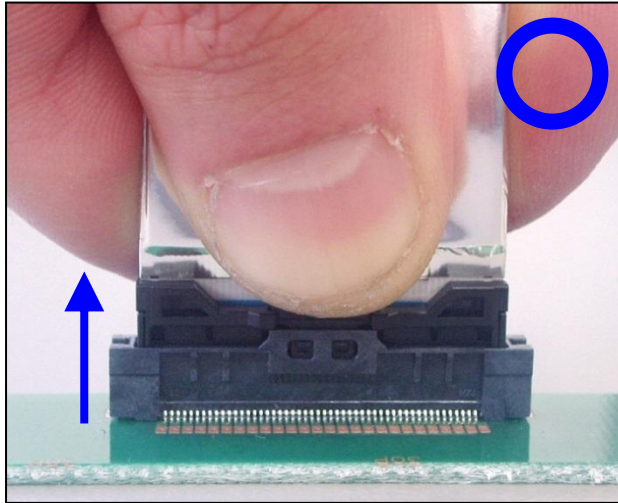

8-4. ご使用のFFCに関して

御社でのFFC選定時には以下を必ずご確認ください、実機での評価/可否判断をお願いします。

高温環境での不具合回避にはFPCの使用をご検討ください。

When actually using it with connector, please do the evaluation and the confirmation with an actual equipment to evade the following case where reliability cannot be filled.

Because an FPC resists heat than FFC; in some cases use the FPC.(high-temperature environment case etc)

FFCに規定された定格温度がFFC単体前提の場合が御座います。

この場合、コネクタと組み合わせての実使用において、高温環境でFFC基材と導体間の接着層が劣化し接着力が低下、その後の温度変動によるコネクタ/FFCの収縮により、導体自体のピッチ方向ズレが発生し、長期的には接点脱落、不導通に至る事例が確認されております。

The adhesive line of FFC is deteriorated by high temperature heat.

Then contact conductor of FFC may move.

ピッチ方向ズレ
Misalignment in pitch direction

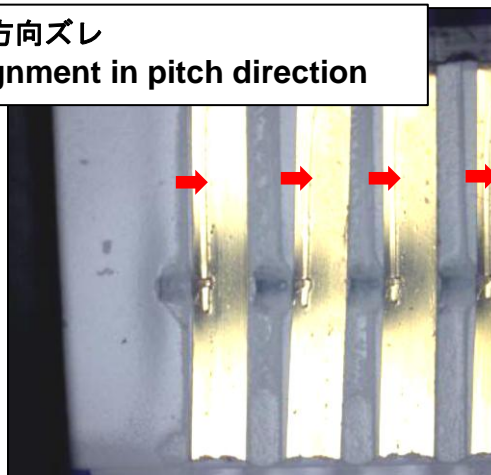

REVISE ON PC ONLY		TITLE:	
E	SEE SHEET 1 OF 18	0.5 mm PITCH FFC TO BOARD CONNECTOR	
	REV.	DESCRIPTION	製品仕様書
		THIS DOCUMENT CONTAINS INFORMATION THAT IS PROPRIETARY TO MOLEX INC. AND SHOULD NOT BE USED WITHOUT WRITTEN PERMISSION	
DOCUMENT NUMBER PS-501786-004		FILE NAME PS501786004.docx	SHEET 16 OF 18
EN-037(2013-04 rev.1)			

また、同様に高温環境で接着層/基材/補強板が軟化してつぶれ、導体部が陥没、基材と導体の境目に段差が発生し、熱サイクルなど温度変動が極端な場合に、初期段階でコネクタ接点が乗り上げて不導通に至る事例も確認されております。

In addition, a pad of FFC is crushed and may become instantaneous interruption and the non-conduction.

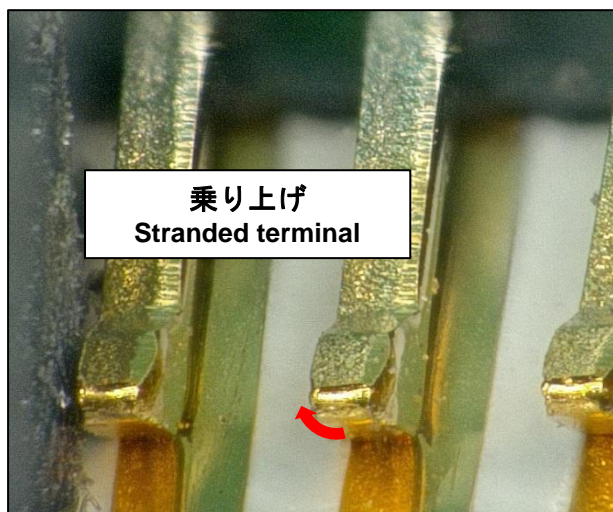
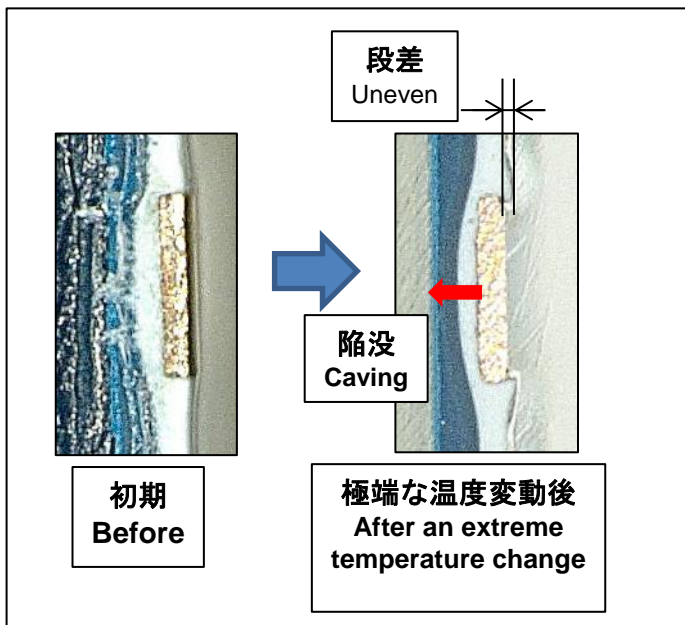

REVISE ON PC ONLY		TITLE:	
E	SEE SHEET 1 OF 18	0.5 mm PITCH FFC TO BOARD CONNECTOR	
	REV. DESCRIPTION	製品仕様書	
		THIS DOCUMENT CONTAINS INFORMATION THAT IS PROPRIETARY TO MOLEX INC. AND SHOULD NOT BE USED WITHOUT WRITTEN PERMISSION	
DOCUMENT NUMBER PS-501786-004		FILE NAME PS501786004.docx	SHEET 17 OF 18
EN-037(2013-04 rev.1)			

molex PRODUCT SPECIFICATION

LANGUAGE

JAPANESE
ENGLISH

REV.	REV. RECORD	DATE	EC NO.	WRITTEN BY :	CHECKED BY :
A	RELEASED	'09/01/30	J2009-1715	M.TAKASAKI	M.HAYASHI
B	REVISED	'09/03/13	J2009-2087	Y.SHIBATA	T.HARUYAMA
C	REVISED	'14/07/28	J2015-0162	N.ASANUMA	K.TAKAHASHI
D	REVISED	'15/04/08	J2015-1346	M.TAKAHASHI04	K.TAKAHASHI
E	REVISED	'15/08/11	J2015-1471	M.TAKAHASHI04	K.TAKAHASHI

REVISE ON PC ONLY		TITLE: 0.5 mm PITCH FFC TO BOARD CONNECTOR 製品仕様書	
E	SEE SHEET 1 OF 18		
REV.	DESCRIPTION	THIS DOCUMENT CONTAINS INFORMATION THAT IS PROPRIETARY TO MOLEX INC. AND SHOULD NOT BE USED WITHOUT WRITTEN PERMISSION	
DOCUMENT NUMBER PS-501786-004		FILE NAME PS501786004.docx	SHEET 18 OF 18
EN-037(2013-04 rev.1)			