

No. of pos.	A <sup>-0.76</sup>	B <sup>-0.25</sup>	C	Part NO.
9	31.19	16.46	25.00 <sup>+0.12</sup> <sub>-0.13</sub>	FDCNXSTCM39S132X
15	39.52	24.79	33.30 <sup>+0.15</sup> <sub>-0.1</sub>	FDCPXSTCM39S132X
25	53.42	38.50	47.04 <sup>+0.13</sup>	FDCRXSTCM39S132X
37	69.70	54.96	63.50 <sup>+0.13</sup>	FDCSXSTCM39S132X

used for: D-SUB FILTER

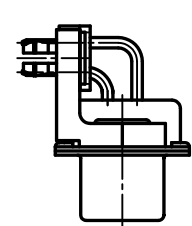
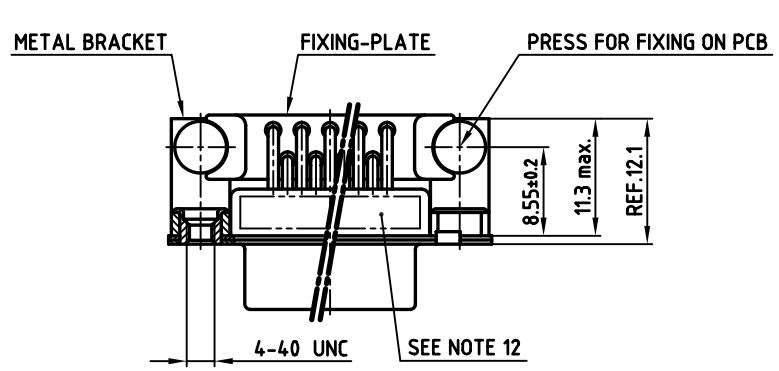
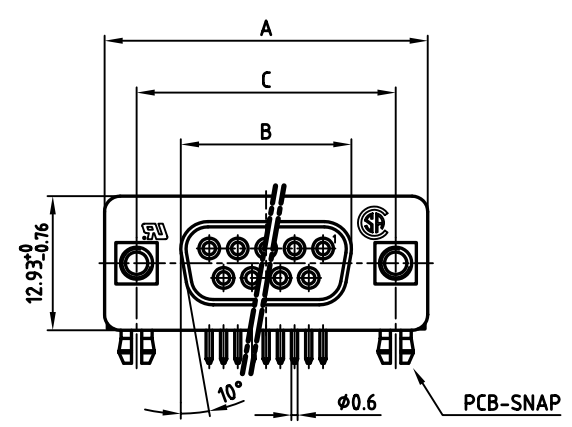
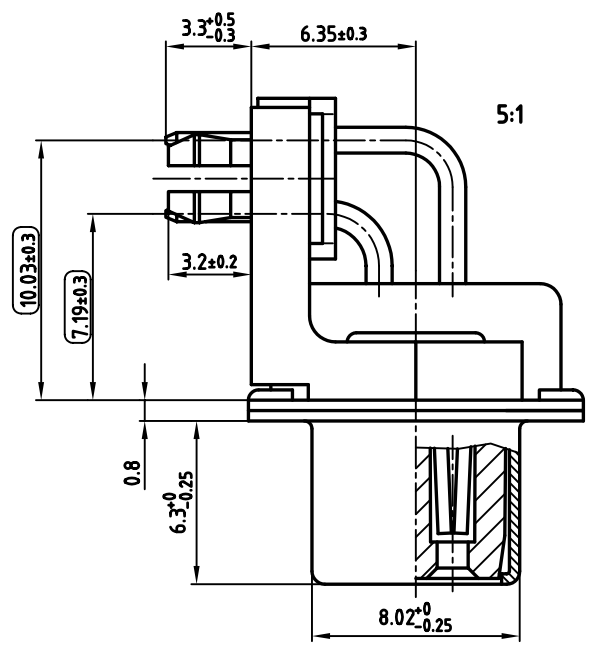

**NOTES:**

- METALSHELLS: COPPER ALLOY; min. 320 $\mu$ " TIN
- INSULATORS: HIGH TEMPERATURE PLASTIC UL 94 V-0, BLACK
- CONTACTS: COPPER ALLOY  
PLATING: 30 $\mu$ " HARD GOLD OVER min. 50 $\mu$ " NICKEL  
CONTACT TAILS PRETINNED
- METAL BRACKET: DIE-CASTING; min. 320 $\mu$ " TIN over 80 $\mu$ " NICKEL
- THREADED INSERT: COPPER ALLOY; min. 200 $\mu$ " TIN over 80 $\mu$ " NICKEL
- PCB-SNAP: COPPER ALLOY; min. 200 $\mu$ " TIN over 80 $\mu$ " NICKEL  
PCB-HOLE:  $\phi 3.1 \pm 0.1$ ; PCB THICKNESS 1.6mm
- FIXING-PLATE: HIGH TEMPERATURE PLASTIC UL 94 V-0, BLACK
- P.C.B. HOLE DRILLINGS ON SHEET 2
- CAPACITANCE: 1300pF  $\pm 20\%$
- DIELECTRIC WITHSTANDING VOLTAGE: 424 VDC
- MAXIMUM TORQUE VALUE FOR THREAD: 6" LBS
- CONNECTOR IS PART MARKED: PART-NO. CONEC ABC
- = CHECK DIMENSION

Directive 2002/95/EC  
RoHS  
Compliant

APPROVAL # FREIGABE # DEBLOCAGE # AUTORIZACION # APPROVAL

CUSTOMER APPROVAL DATE:

NAME: TITLE:

COMPANY NAME:

APPROVAL # FREIGABE # DEBLOCAGE # AUTORIZACION # APPROVAL

THIS DRAWING MAY NOT BE COPIED OR REPRODUCED IN ANY WAY, AND MAY NOT BE PASSED ON TO A THIRD PARTY, WITHOUT WRITTEN PERMISSION. OWNERSHIP AND COPYRIGHT OF CONEC GmbH DO NOT ALTER CAD DRAWING BY HAND

rev.	description	date	name
a	Origin		

tolerance		dim. in mm	
2006	date	name	
drawn	24.03.	Lehmenkühler	
appd.	24.03.	Mickenbecker	
norm	DIN 41652		
d-old			

scale: 2:1 (5:1)

material: SEE NOTES

title: **D-SUB FILTER FEMALE 90°**  
9-37pos. 0.318inch  
threaded insert, metal bracket, fixing-plate, clip

dwg no: AutoCAD 2006 DIN-A 3 sh:1/2

**24K2A771**

part no: SEE TABLE



9pos.

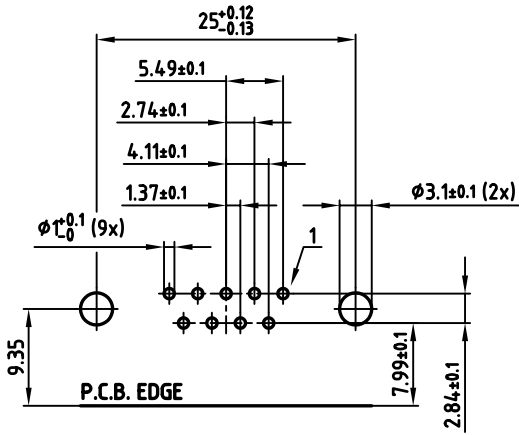

25pos.

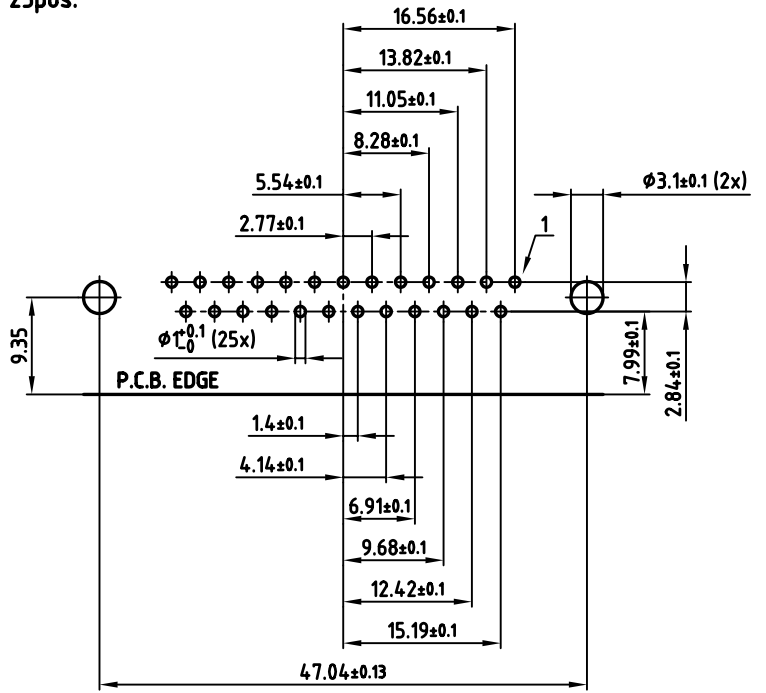

15pos.

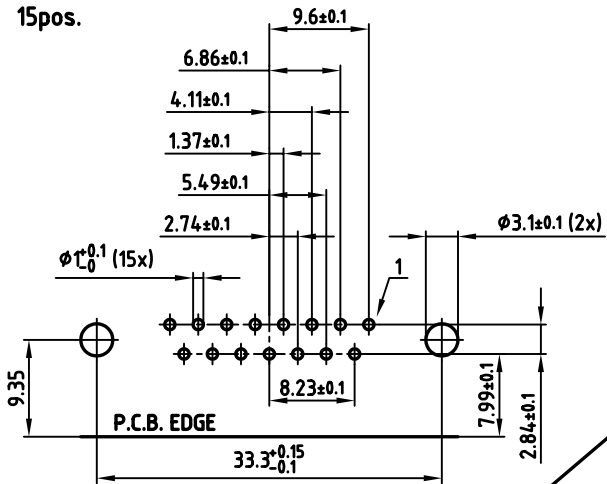

37pos.

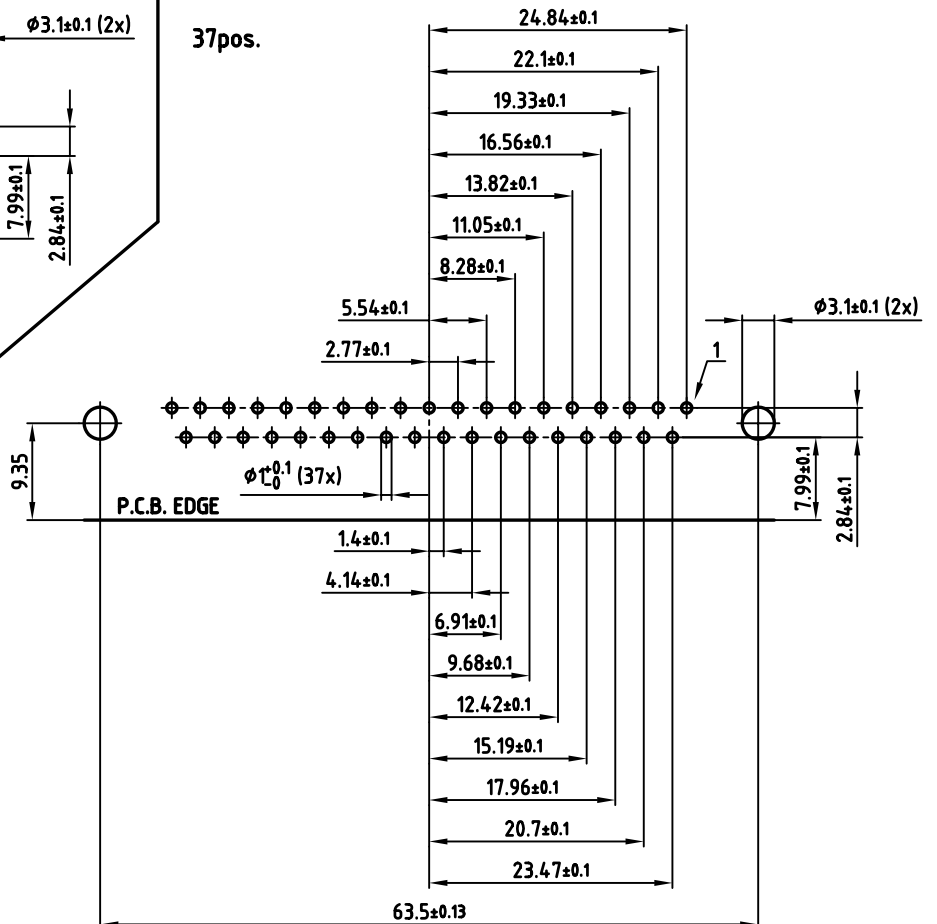

used for: D-SUB FILTER

APPROVAL # FREIGABE # DEBLOCAGE # AUTORIZACION # APPROVAL

CUSTOMER APPROVAL DATE:

NAME: TITLE:

COMPANY NAME:

APPROVAL # FREIGABE # DEBLOCAGE # AUTORIZACION # APPROVAL

THIS DRAWING MAY NOT BE COPIED OR REPRODUCED IN ANY WAY, AND MAY NOT BE PASSED ON TO A THIRD PARTY, WITHOUT WRITTEN PERMISSION. OWNERSHIP AND COPYRIGHT OF CONEC GmbH DO NOT ALTER CAD DRAWING BY HAND

tolerance	dim. in mm	
2006	date	name
drawn	24.03.	Lehmenkühler
appd.	24.03.	Mickenbecker
norm	DIN 41652	
d-old		
a	Origin	
rev.	description	date name

scale: 2:1

material: SEE SHEET 1

title: P.C.B. HOLE DRILLINGS

D-SUB FILTER FEMALE 90° 9-37pos. 0.318inch threaded insert, metal bracket, fixing-plate, clip

dwg no: AutoCAD 2006 DIN-A 3 sh:2/2

part no: SEE SHEET 1

