

SECTION A-A  
(WITH CAP)

SECTION A-A  
(WITHOUT CAP)

NOTES:

- MATERIAL:  
HOUSING: NYLON, GLASS FILLED, UL94 V-0,  
COLOR - SEE TABLE.  
CAP: NYLON, GLASS FILLED, UL94V-0  
COLOR: BEIGE.  
PINS: BRASS ALLOY, C26000, P/N87437-8083.
- PLATING: 2.54µM. MIN. TIN OVER 1.27µM MIN. NICKEL.
- DRAWING SHOWS PLUG WITH 5 CIRCUITS.
- HEADER TO BE USED WITH CRIMP HOUSING, P/N 87439  
AND CRIMP TERMINAL, P/N 87421.
- PARTS TO BE PACKED IN MOISTURE BAG.

|                                                                                   |            |                                |                    |
|-----------------------------------------------------------------------------------|------------|--------------------------------|--------------------|
| ADD MOIST BAG NOTE<br>EC NO: S2007-1049<br>DRWNS:KANG<br>CHKD:ATSEE<br>APPR:MLONG | 2007/06/22 | QUALITY SYMBOLS<br>▽=0<br>▽C=0 | DESCRIPTION<br>REV |
|                                                                                   | 2007/06/22 |                                |                    |
|                                                                                   | 2007/06/22 |                                |                    |
|                                                                                   | 2007/06/22 |                                |                    |
| D7                                                                                |            |                                |                    |

| GENERAL TOLERANCES (UNLESS SPECIFIED)                |       |
|------------------------------------------------------|-------|
| mm                                                   | INCH  |
| 4 PLACES ± ---                                       | ± --- |
| 3 PLACES ± ---                                       | ± --- |
| 2 PLACES ± 0.20                                      | ± --- |
| 1 PLACE ± ---                                        | ± --- |
| ANGULAR ± 3°                                         |       |
| DRAFT WHERE APPLICABLE MUST REMAIN WITHIN DIMENSIONS |       |

| DIMENSION STYLE<br>MM ONLY |                                                                                                                               |
|----------------------------|-------------------------------------------------------------------------------------------------------------------------------|
| DRAWN BY                   | DATE                                                                                                                          |
| KCL ING                    | 1994/04/08                                                                                                                    |
| CHECKED BY                 | DATE                                                                                                                          |
| SKTOH                      | 1994/04/21                                                                                                                    |
| APPROVED BY                | DATE                                                                                                                          |
| RWONG                      | 1994/04/21                                                                                                                    |
| MATERIAL NO.               | DOCUMENT NO.                                                                                                                  |
| SEE TABLE                  | SD-87437-***31                                                                                                                |
| SIZE<br>A3                 | THIS DRAWING CONTAINS INFORMATION THAT IS PROPRIETARY TO MOLEX INCORPORATED AND SHOULD NOT BE USED WITHOUT WRITTEN PERMISSION |

|                                              |                        |                        |
|----------------------------------------------|------------------------|------------------------|
| SCALE<br>NTS                                 | DESIGN UNITS<br>METRIC | THIRD ANGLE PROJECTION |
| 1.50MM PITCH, W-T-B<br>HEADER, VERTICAL, SMT |                        |                        |
| MOLEX INCORPORATED                           |                        |                        |
| DOCUMENT NO.<br>SD-87437-***31               |                        | SHEET NO.<br>1 OF 4    |

10 9 8 7 6 5 4 3 2 1



| CIRCUIT SIZE | A     | B     | C     | D     | E     |
|--------------|-------|-------|-------|-------|-------|
| 02           | 1.50  | 3.30  | 3.70  | 4.30  | 1.70  |
| 03           | 3.00  | 4.80  | 5.20  | 5.80  | 3.20  |
| 04           | 4.50  | 6.30  | 6.70  | 7.30  | 4.70  |
| 05           | 6.00  | 7.80  | 8.20  | 8.80  | 6.20  |
| 06           | 7.50  | 9.30  | 9.70  | 10.30 | 7.70  |
| 07           | 9.00  | 10.80 | 11.20 | 11.80 | 9.20  |
| 08           | 10.50 | 12.30 | 12.70 | 13.30 | 10.70 |
| 09           | 12.00 | 13.80 | 14.20 | 14.80 | 12.20 |
| 10           | 13.50 | 15.30 | 15.70 | 16.30 | 13.70 |
| 11           | 15.00 | 16.80 | 17.20 | 17.80 | 15.20 |
| 12           | 16.50 | 18.30 | 18.70 | 19.30 | 16.70 |
| 13           | 18.00 | 19.80 | 20.20 | 20.80 | 18.20 |
| 14           | 19.50 | 21.30 | 21.70 | 22.30 | 19.70 |
| 15           | 21.00 | 22.80 | 23.20 | 23.80 | 21.20 |

PART NUMBER ASSIGNMENT

87437-XXXX

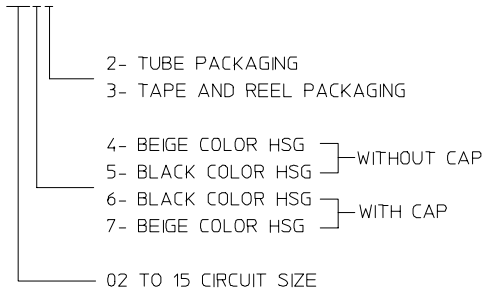

F

E

D

C

B

A

F

E

D

C

B

A

| ADD MOIST BAG NOTE<br>EC NO: S2007-1049<br>DRWNS:KANG<br>CHKD:ATSEE<br>APPR:MLONG | 2007/06/22<br>2007/06/22<br>2007/06/22 | DESCRIPTION<br>REV                                 | QUALITY SYMBOLS<br>▽=0<br>▽=0 | GENERAL TOLERANCES (UNLESS SPECIFIED)<br><table border="1"> <thead> <tr> <th></th> <th>mm</th> <th>INCH</th> </tr> </thead> <tbody> <tr><td>4 PLACES</td><td>± ---</td><td>± ---</td></tr> <tr><td>3 PLACES</td><td>± ---</td><td>± ---</td></tr> <tr><td>2 PLACES</td><td>± 0.20</td><td>± ---</td></tr> <tr><td>1 PLACE</td><td>± ---</td><td>± ---</td></tr> </tbody> </table> ANGULAR ± 3 ° |       | mm | INCH | 4 PLACES | ± --- | ± --- | 3 PLACES | ± --- | ± --- | 2 PLACES | ± 0.20 | ± --- | 1 PLACE | ± --- | ± --- | DIMENSION STYLE<br>MM ONLY | SCALE<br>NTS | DESIGN UNITS<br>METRIC | THIRD ANGLE PROJECTION |
|-----------------------------------------------------------------------------------|----------------------------------------|----------------------------------------------------|-------------------------------|-------------------------------------------------------------------------------------------------------------------------------------------------------------------------------------------------------------------------------------------------------------------------------------------------------------------------------------------------------------------------------------------------|-------|----|------|----------|-------|-------|----------|-------|-------|----------|--------|-------|---------|-------|-------|----------------------------|--------------|------------------------|------------------------|
|                                                                                   |                                        |                                                    |                               | mm                                                                                                                                                                                                                                                                                                                                                                                              | INCH  |    |      |          |       |       |          |       |       |          |        |       |         |       |       |                            |              |                        |                        |
|                                                                                   |                                        |                                                    | 4 PLACES                      | ± ---                                                                                                                                                                                                                                                                                                                                                                                           | ± --- |    |      |          |       |       |          |       |       |          |        |       |         |       |       |                            |              |                        |                        |
|                                                                                   |                                        |                                                    | 3 PLACES                      | ± ---                                                                                                                                                                                                                                                                                                                                                                                           | ± --- |    |      |          |       |       |          |       |       |          |        |       |         |       |       |                            |              |                        |                        |
| 2 PLACES                                                                          | ± 0.20                                 | ± ---                                              |                               |                                                                                                                                                                                                                                                                                                                                                                                                 |       |    |      |          |       |       |          |       |       |          |        |       |         |       |       |                            |              |                        |                        |
| 1 PLACE                                                                           | ± ---                                  | ± ---                                              |                               |                                                                                                                                                                                                                                                                                                                                                                                                 |       |    |      |          |       |       |          |       |       |          |        |       |         |       |       |                            |              |                        |                        |
| DRAWN BY<br>KCLING                                                                | DATE<br>1994/04/08                     | TITLE<br>1.50MM PITCH, W-T-B HEADER, VERTICAL, SMT |                               |                                                                                                                                                                                                                                                                                                                                                                                                 |       |    |      |          |       |       |          |       |       |          |        |       |         |       |       |                            |              |                        |                        |
| CHECKED BY<br>SKTOH                                                               | DATE<br>1994/04/21                     | MOLEX INCORPORATED                                 |                               |                                                                                                                                                                                                                                                                                                                                                                                                 |       |    |      |          |       |       |          |       |       |          |        |       |         |       |       |                            |              |                        |                        |
| APPROVED BY<br>RWONG                                                              | DATE<br>1994/04/21                     | MATERIAL NO.<br>SEE TABLE                          | DOCUMENT NO.<br>SD-87437-**31 | SHEET NO.<br>2 OF 4                                                                                                                                                                                                                                                                                                                                                                             |       |    |      |          |       |       |          |       |       |          |        |       |         |       |       |                            |              |                        |                        |

9 8 7 6 5 4 3 2 1

10 9 8 7 6 5 4 3 2 1

EMBOSSED CARRIER TAPE PACKING DETAILS FOR PARTS WITHOUT CAP



DETAIL A (ELONGATED HOLE)

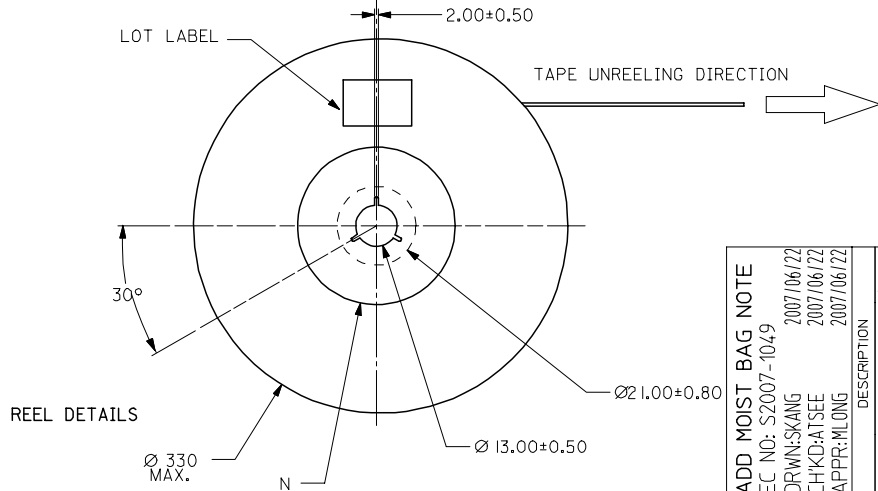
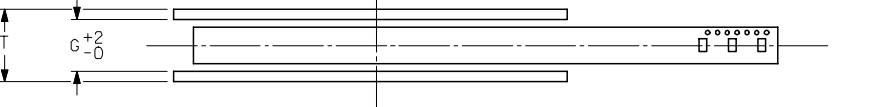
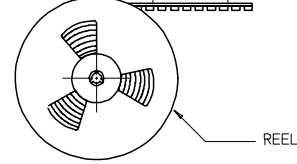

|                    |             |
|--------------------|-------------|
| ADD MOIST BAG NOTE | DESCRIPTION |
| EC NO: S2007-1049  | DRWNS:SKANG |
| 2007/06/22         | CHKD:ATSEE  |
| 2007/06/22         | APPR:MLONG  |
| D7                 | REV         |

|                 |                     |
|-----------------|---------------------|
| QUALITY SYMBOLS | $\nabla=0$          |
|                 | $\sphericalangle=0$ |

|                                                      |                       |           |
|------------------------------------------------------|-----------------------|-----------|
| GENERAL TOLERANCES (UNLESS SPECIFIED)                | DIMENSION STYLE       |           |
|                                                      | MM ONLY               |           |
|                                                      | mm                    | INCH      |
| 4 PLACES                                             | $\pm$ ---             | $\pm$ --- |
| 3 PLACES                                             | $\pm$ ---             | $\pm$ --- |
| 2 PLACES                                             | $\pm 0.20$            | $\pm$ --- |
| 1 PLACE                                              | $\pm$ ---             | $\pm$ --- |
|                                                      | ANGULAR $\pm 3^\circ$ |           |
| DRAFT WHERE APPLICABLE MUST REMAIN WITHIN DIMENSIONS |                       |           |

|              |                                                                                                                               |                                           |
|--------------|-------------------------------------------------------------------------------------------------------------------------------|-------------------------------------------|
| DRAWN BY     | DATE                                                                                                                          | TITLE                                     |
| KCLING       | 1994/04/08                                                                                                                    | 1.50MM PITCH, W-T-B HEADER, VERTICAL, SMT |
| CHECKED BY   | DATE                                                                                                                          |                                           |
| SKTOH        | 1994/04/21                                                                                                                    |                                           |
| APPROVED BY  | DATE                                                                                                                          |                                           |
| RWONG        | 1994/04/21                                                                                                                    |                                           |
| MATERIAL NO. |                                                                                                                               | DOCUMENT NO.                              |
| SEE TABLE    |                                                                                                                               | SD-87437-**31                             |
| SIZE         | THIS DRAWING CONTAINS INFORMATION THAT IS PROPRIETARY TO MOLEX INCORPORATED AND SHOULD NOT BE USED WITHOUT WRITTEN PERMISSION |                                           |
| A3           |                                                                                                                               |                                           |

|                    |              |                        |
|--------------------|--------------|------------------------|
| SCALE              | DESIGN UNITS | THIRD ANGLE PROJECTION |
| NTS                | METRIC       |                        |
| MOLEX INCORPORATED |              |                        |
| DOCUMENT NO.       |              | SHEET NO.              |
| SD-87437-**31      |              | 3 OF 4                 |

9 8 7 6 5 4 3 2 1

EMBOSSED CARRIER TAPE PACKING DETAILS FOR PARTS WITH CAP

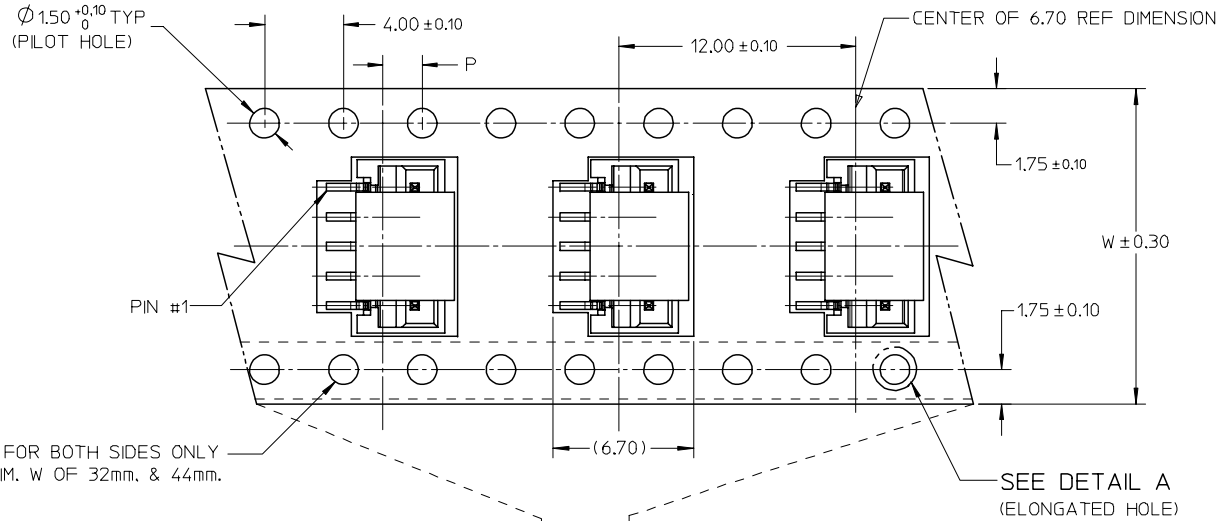

NOTES:

1. LEADER AND TRAILER TAPE

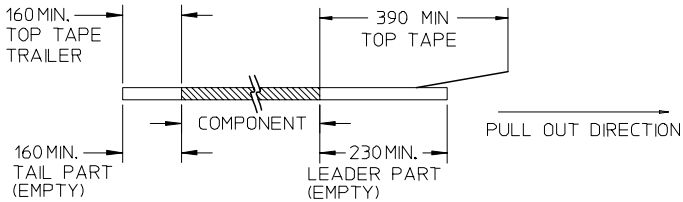

2. PEELING OFF FORCE OF THE TOP TAPE: 20-80gf. (PEELING DIRECTION AS SHOWN IN FOLLOWING FIGURE)

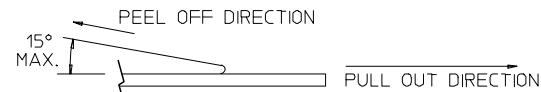

- 3. THE TAPE IS TREATED FOR ANTI-STATIC.
- 4. PACKAGING STANDARD IS AS PER EIA-481.
- 5. TAPE & REEL QUANTITY = 1000PCS/REEL (WITHOUT CAP)  
TAPE & REEL QUANTITY = 900PCS/REEL (WITH CAP)

|                |    |            |     |       |       |           |
|----------------|----|------------|-----|-------|-------|-----------|
| 15             | 44 | 20.20±0.15 | 100 | 44.40 | 50.40 | 2.00±0.15 |
| 11, 12, 13, 14 | 32 | 14.20±0.10 | 100 | 32.40 | 38.40 | 2.00±0.10 |
| 7, 8, 9, 10    | 24 | 11.50±0.10 | 100 | 24.40 | 30.40 | 2.00±0.10 |
| 2, 3, 4, 5, 6  | 16 | 7.50±0.10  | 100 | 16.40 | 22.40 | 2.00±0.10 |
| CIRCUIT SIZE   | W  | F          | N   | G     | T MAX | P         |

|                                                                                   |                                        |                               |                                       |  |                                |  |                    |                                                       |                        |  |
|-----------------------------------------------------------------------------------|----------------------------------------|-------------------------------|---------------------------------------|--|--------------------------------|--|--------------------|-------------------------------------------------------|------------------------|--|
| ADD MOIST BAG NOTE<br>EC NO: S2007-1049<br>DRWNS:KANG<br>CHKD:ATSEE<br>APPR:MLONG | 2007/06/22<br>2007/06/22<br>2007/06/22 | QUALITY SYMBOLS<br>▽=0<br>▽=0 | GENERAL TOLERANCES (UNLESS SPECIFIED) |  | DIMENSION STYLE<br>MM ONLY     |  | SCALE<br>NTS       | DESIGN UNITS<br>METRIC                                | THIRD ANGLE PROJECTION |  |
|                                                                                   |                                        |                               |                                       |  | DRAWN BY<br>KCLING             |  | DATE<br>1994/04/08 | TITLE<br>1.50MM PITCH, W-T-B<br>HEADER, VERTICAL, SMT |                        |  |
|                                                                                   |                                        |                               |                                       |  | CHECKED BY<br>SKTOH            |  | DATE<br>1994/04/21 | APPROVED BY<br>RWONG                                  |                        |  |
|                                                                                   |                                        |                               |                                       |  | APPROVED BY<br>RWONG           |  | DATE<br>1994/04/21 | MATERIAL NO.<br>SEE TABLE                             |                        |  |
| DRAFT WHERE APPLICABLE<br>MUST REMAIN<br>WITHIN DIMENSIONS                        |                                        |                               | SIZE<br>A3                            |  | DOCUMENT NO.<br>SD-87437-**-31 |  |                    | SHEET NO.<br>4 OF 4                                   |                        |  |