

Capacitive Controller ICs

Capacitive Switch Controller ICs

BU21079F

General Description

BU21079F is a capacitive switch controller used for operating switches. Low power consumption is achieved using the intermittent operation mode. In addition to a regular simple switch, it supports matrix switches which are arranged in the matrix sensors. If external noise and temperature drift are detected, the automatic self-calibration is activated.

Key Specifications

■ Input voltage range	3.0V to 5.5V
■ Operating temperature range	-25°C to 85°C
■ Operating current	2.5mA (Typ)
■ Detect cycle	6msec (Typ)

Packages

BU21079F :

Features

- 8 capacitive sensor ports
- Supports matrix switches. Maximum of 16 switches.
- Automatic self-calibration
- Continued touch detection
- Sends an interrupt when there is a detected result of switch operation
- 2-wire serial bus interface
- 3.3V or 5.0V single power supply
- Built-in Power-On-Reset and Oscillator



SOP16
10.00 mm×6.20 mm×1.71 mm

Applications

- Electronic devices with multiple switches.
- Information appliances such as printers.
- AV appliances such as digital TV and HDD recorder.
- Notebook PC.
- Air-conditioner. Refrigerator. Electrical rice cooker.

Typical Application Circuit

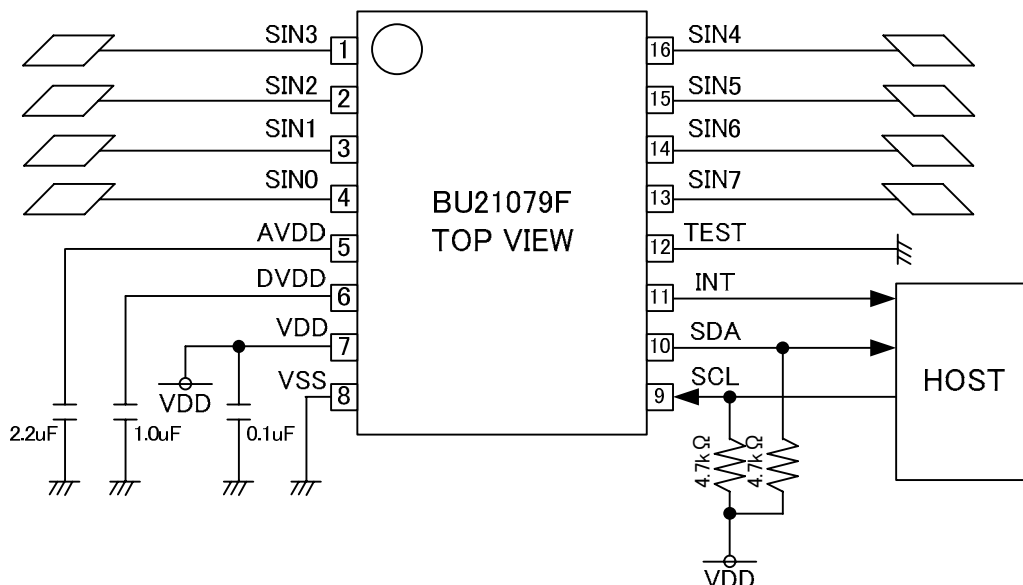

Figure 1. Typical Application Circuit

OVERVIEW

BU21079F is a capacitive sensor controller for switch operation.

BU21079F has the following blocks: AFE (Analog Front End) detecting capacitance, A/D converter, MPU, 2-wire serial bus interface compatible with I2C protocol, power-on-reset, and oscillator. It is operated with a 3.0V to 5.5V single power supply.

The results detected during switch operations (Touch/Release/Hold) are stored in a register. An interrupt is sent from INT port to the host when a register is updated during operations. If external noise and temperature drift are detected, automatic self-calibration is activated. When continuous monitoring of the host is unnecessary, the load of the host will be reduced.

Intermittent operation

When touch ON is detected, its operation shifts from intermittent operation to normal operation. When touch OFF is detected, its operation shifts from normal operation to intermittent operation, and the operating power is decreased. Sensing during intermittent operation is called "check sensing" and sensing during normal operation is called "normal sensing".

Simple switch

One sensor is assigned to one switch. Each simple switch has the registers for the detected Touch/Release/Hold operations. Simple switches support multi-detect Touch/Release/Hold. It is possible to mask unused switches.

Matrix switches

The cross points of the sensors which are arranged in a matrix can be assigned to individual switches. Each matrix switch has registers for detected Touch/Release/Hold operations. Matrix switches do not support multi-detect Touch/Release/Hold. It is possible to mask unused matrix switches. BU21079F supports 16 matrix switches configured by 4x4 sensors.

Automatic self-calibration

BU21079F checks the status of the sensors based on the detected result. If external noise and temperature drift are detected, the automatic self-calibration is activated in order to get stable detection.

Host interface

BU21079F is slave device for the host device. 2-wire serial bus is compatible with I2C protocol. Slave Address Is 0x5C.

Pin Configurations

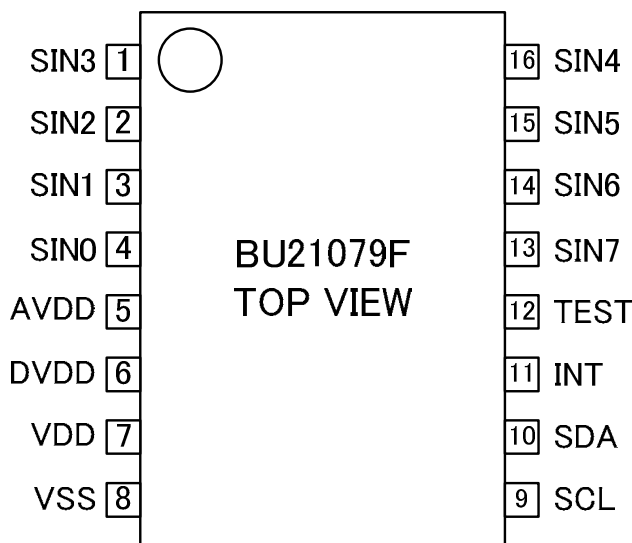

Figure 2. Pin configuration of BU21079F

Pin Descriptions

Pin Number	Pin Name	Type	Function	Note	Power	Initial condition	I/O Equivalence circuit
1	SIN3	Ain	Capacitive Touch Sensor 3		AVDD	Hi-Z	Fig.3
2	SIN2	Ain	Capacitive Touch Sensor 2		AVDD	Hi-Z	Fig.3
3	SIN1	Ain	Capacitive Touch Sensor 1		AVDD	Hi-Z	Fig.3
4	SIN0	Ain	Capacitive Touch Sensor 0		AVDD	Hi-Z	Fig.3
5	AVDD	Power	LD0 output for analog blocks		—	—	—
6	DVDD	Power	LD0 output for digital blocks		—	—	—
7	VDD	Power	Power		—	—	—
8	VSS	GND	Ground		—	—	—
9	SCL	In	Host I/F:SCL input pin		VDD	Hi-Z	Fig.4
10	SDA	InOut	Host I/F:SDA input/output pin		VDD	Hi-Z	Fig.4
11	INT	Out	Interrupt output	Interrupt "H"	VDD	L	Fig.4
12	TEST	In	Test input	Fix "L" at the normal operation	VDD	—	Fig.5
13	SIN7	Ain	Capacitive Touch Sensor 7		AVDD	Hi-Z	Fig.3
14	SIN6	Ain	Capacitive Touch Sensor 6		AVDD	Hi-Z	Fig.3
15	SIN5	Ain	Capacitive Touch Sensor 5		AVDD	Hi-Z	Fig.3
16	SIN4	Ain	Capacitive Touch Sensor 4		AVDD	Hi-Z	Fig.3

I/O Equivalent Circuits

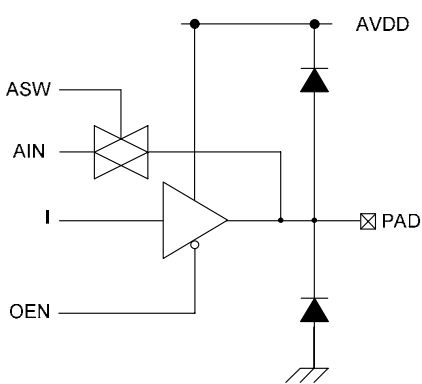

Figure 3. I/O equivalent circuit (a)

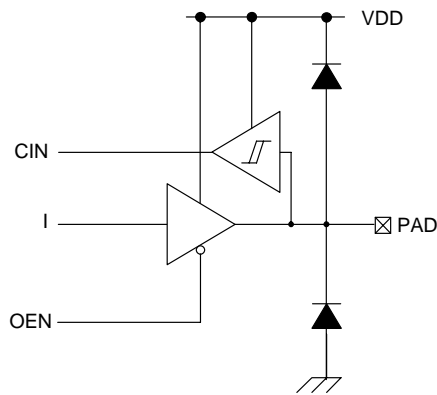

Figure 4. I/O equivalent circuit (b)

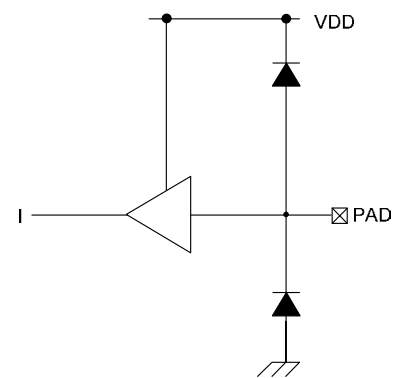

Figure 5. I/O equivalent circuit (c)

Block Diagram

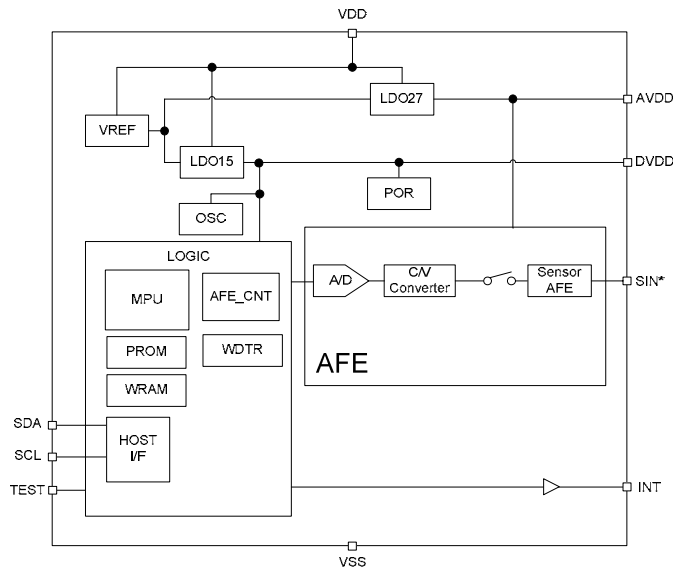

Figure 6. Block Diagram

Description of Blocks

Sensor AFE、C/V Converter

Converts capacitance from the sensors to voltage.

A/D

Converts the voltage from C/V Converter to digital.

LDO27

2.7V output LDO for Sensor AFE, C/V Converter and A/D.

LDO15

1.5V output LDO for OSC and digital blocks.

OSC

Ring oscillator used for the system clock.

POR

Power-On-Reset monitoring LDO15 for system reset.

MPU

Controls switch operations based on the sensing results and run Auto-calibration.

INT port informs the host that switch operations are detected.

PROM

Programmable ROM for the built-in MPU.

WRAM

Work RAM for the built-in MPU.

HOST I/F

2-wire serial bus interface compatible with I2C protocol.

AFE_CNT

Sequencer of Sensor AFE, C/V converter and A/D.

WDTR

Watchdog Timer Reset. It operates as the system resets. If MPU hangs-up, Watchdog Timer Reset can reset the IC.

Absolute Maximum Ratings (Ta = 25°C)

Parameter	Symbol	Rating	Unit
Power supply voltage	VDD	-0.5 to 7.0	V
Input voltage	V _{IN}	-0.5 to VDD + 0.3	V
Storage temperature range	T _{stg}	-55 to 125	°C
Permissible loss	P _d	0.30 ^{*1}	W
Maximum junction temperature	T _{jmax}	125	°C

*1 Derate by 3.00mW/°C when operating above Ta =25°C. (IC only).

When mounted in a Rohm standard board (70mm x 70mm x 1.6t mm), Pd is 0.50W, and it reduces in 5.00mW/°C over Ta=25°C.

Recommended Operating Conditions

Parameter	Symbol	Rating	Unit
Power supply voltage	VDD	3.0 to 5.5	V
Operating temperature range	T _{opr}	-20 to 85	°C

Electrical Characteristics (Ta = 25°C , VDD = 3.3V , VSS = 0V)

Parameter	Symbol	Rating			Unit	Condition
		Min.	Typ.	Max.		
Input High voltage	V _{IH}	VDD x 0.7	-	VDD + 0.3	V	
Input Low voltage	V _{IL}	VSS - 0.3	-	VDD x 0.3	V	
Output High voltage	V _{OH}	VDD - 0.5	-	VDD	V	I _{OH} = -4mA
Output Low voltage	V _{OL}	VSS	-	VSS + 0.5	V	I _{OL} = 4mA
Oscillator clock frequency1	f _{OSC1}	45	50	55	MHz	
Oscillator clock frequency2	f _{OSC2}	51.2	64	76.8	KHz	
DVDD LDO output voltage	V _{DVDD}	1.35	1.50	1.65	V	
AVDD LDO output voltage	V _{AVDD}	2.61	2.71	2.81	V	
Full scan operating current	I _{DD}	-	2.5	-	mA	No load of sensors.
Intermittent operating current	I _{INT}		75		uA	Intermittent operation cycle 200m s

Register Map (OSC = 50MHz, unless otherwise noted.)
 No accessing to the reserved areas is allowed

Group	Address	Name	R/W	Ini	7	6	5	4	3	2	1	0
Detect value	0x00	SIN_DATA0	R	0x00	SD_SIN0							
	0x01	SIN_DATA1	R	0x00	SD_SIN1							
	0x02	SIN_DATA2	R	0x00	SD_SIN2							
	0x03	SIN_DATA3	R	0x00	SD_SIN3							
	0x04	SIN_DATA4	R	0x00	SD_SIN4							
	0x05	SIN_DATA5	R	0x00	SD_SIN5							
	0x06	SIN_DATA6	R	0x00	SD_SIN6							
	0x07	SIN_DATA7	R	0x00	SD_SIN7							
	0x08	SIN_DATA8	R	0x00	SD_SIN8							
	0x09-0F	reserved	R	0x00	-							
Detect result	0x10	INTERRUPT	R	0x00	CONDET	OFFDET	ONDET	PERCAL	WDT	ERCAL	CAL	INI
	0x11	SIN_STATE	R	0x00	SIN7_STAT	SIN6_STAT	SIN5_STAT	SIN4_STAT	SIN3_STAT	SIN2_STAT	SIN1_STAT	SIN0_STAT
	0x12	Reserved	R	0x00	-							
	0x13	DETECT_SW_ON	R	0x00	SW7_ON	SW6_ON	SW5_ON	SW4_ON	SW3_ON	SW2_ON	SW1_ON	SW0_ON
	0x14	DETECT_SLIDER_ON	R	0x00	SLIDER_ON	SLIDER_CNT						
	0x15	DETECT_MAT_ON	R	0x00	MAT_ON	-			KEY_ON			
	0x16	DETECT_SW_OFF	R	0x00	SW7_OFF	SW6_OFF	SW5_OFF	SW4_OFF	SW3_OFF	SW2_OFF	SW1_OFF	SW0_OFF
	0x17	DETECT_SLIDER_OFF	R	0x00	SLIDER_OFF	-						
	0x18	DETECT_MAT_OFF	R	0x00	MAT_OFF	-			KEY_OFF			
	0x19	DETECT_SW_CONT	R	0x00	SW7_CONT	SW6_CONT	SW5_CONT	SW4_CONT	SW3_CONT	SW2_CONT	SW1_CONT	SW0_CONT
	0x1A	Reserved	R	0x00	-							
	0x1B	DETECT_MAT_CONT	R	0x00	MAT_CONT	-			KEY_CONT			
	0x1C	STATE	R	0x00	E_CALIB	-	-	-	-	-	INTVL	CALIB
	0x1D	Reserved	R	0x00	-							
	0x1E	RACT	R	0x00	RACT							
0x1F-84	Reserved	R	0x00	-								
Reset setting	0x85	SOFTRESET0	R/W	0x00	SRST[7:0]							
	0x86-89	Reserved	-	-	reserved							
	0x8A	SOFTRESET1	R/W	0x00	SRST[15:8]							
-	0x8B-BF	Reserved	-	-	reserved							
Sensor setting	0xC0	CFG_SIN_1_0	R/W	0x00	GA_SIN1		ON_SIN1		GA_SIN0		ON_SIN0	
	0xC1	CFG_SIN_3_2	R/W	0x00	GA_SIN3		ON_SIN3		GA_SIN2		ON_SIN2	
	0xC2	CFG_SIN_5_4	R/W	0x00	GA_SIN5		ON_SIN5		GA_SIN4		ON_SIN4	
	0xC3	CFG_SIN_7_6	R/W	0x00	GA_SIN7		ON_SIN7		GA_SIN6		ON_SIN6	
	0xC4	CFG_SIN_x_8	R/W	0x00	-		-		GA_SIN8		ON_SIN8	
	0xC5-C7	Reserved	R/W	0x00	-							
	0xC8	GAIN_1_0	R/W	0x00	GA1				GA0			
	0xC9	GAIN_x_2	R/W	0x00	-				GA2			
	0xCA	ON_TH0	R/W	0x00	ON0							
	0xCB	ON_TH1	R/W	0x00	ON1							
	0xCC	ON_TH2	R/W	0x00	ON2							
	0xCD	OFF_TH	R/W	0x00	-	OFF						
	0xCE	OVERSAMPLES	R/W	0x00	OST				-			
	0xCF	CONTTIMES	R/W	0x00	CONTSSEL	-	CONT					

Register Map (OSC = 50MHz, unless otherwise specified).
 Access to reserved areas is restricted.

Group	Address	Name	R/W	Ini	7	6	5	4	3	2	1	0
Mask setting	0xD0	MSK_DETECT_SW	R/W	0x00	MSK_SW7	MSK_SW6	MSK_SW5	MSK_SW4	MSK_SW3	MSK_SW2	MSK_SW1	MSK_SW0
	0xD1	Reserved	R/W	0x00	-							
	0xD2	MSK_DETECT_MAT0	R/W	0x00	MSK_KEYH	MSK_KEYG	MSK_KEYF	MSK_KEYE	MSK_KEYD	MSK_KEYC	MSK_KEYB	MSK_KEYA
	0xD3	MSK_DETECT_MAT1	R/W	0x00	MSK_KEYP	MSK_KEYO	MSK_KEYN	MSK_KEYM	MSK_KEYL	MSK_KEYK	MSK_KEYJ	MSK_KEYI
	0xD4-D8	Reserved	R/W	0x00	-							
	0xD9	EN_SLIDER	R/W	0x00	EN_SLID_SIN7	EN_SLID_SIN6	EN_SLID_SIN5	EN_SLID_SIN4	EN_SLID_SIN3	EN_SLID_SIN2	EN_SLID_SIN1	EN_SLID_SIN0
	0xDA	KEEP_SENS_NUM	R/W	0x00	KEEP_SENS_NUM							
	0xDB	UNIT_SENS_NUM	R/W	0x00	-				UNIT_SENS_NUM			
	0xDC	TH_SLEEP_H	R/W	0x00	TH_SLEEP[15:8]							
	0xDD	TH_SLEEP_L	R/W	0x00	TH_SLEEP[7:0]							
	0xDE	OUTPUT_OFFSET	R/W	0x00	OUTPUT_OFFSET							
0xDF	MSK_INTERRUPT	R/W	0x00	-	-	-	MSK_PERCAL	MSK_WDT	MSK_ERCAL	MSK_CAL	-	
Analog setting	0xE0	MODE_CONFIG0	R/W	0x00	-	-	FIX_BASE_CYC	FIX_SNS_CYC	-	SLID_LOOP	EN_DSLP	EN_SLP
	0xE1	MODE_CONFIG1	R/W	0x00	DIS_SIN8	-	-	PERCAL_DIS	RET_DIS	HOP_DIS	ERROR_DIS	DRIFT_DIS
	0xE2	EN_SIN	R/W	0x00	EN_SIN7	EN_SIN6	EN_SIN5	EN_SIN4	EN_SIN3	EN_SIN2	EN_SIN1	EN_SIN0
	0xE3	SENS_NUM	R/W	0x00	SENS_NUM							
	0xE4	SENS_RD_TIME	R/W	0x00	SENS_RD_TIME							
	0xE5	SENS_RST_TIME	R/W	0x00	SENS_RST_TIME							
	0xE6	SENS_IRST_TIME	R/W	0x00	SENS_IRST_TIME							
	0xE7	CHK_NUM	R/W	0x00	CHK_NUM							
	0xE8	CHK_RD_TIME	R/W	0x00	CHK_RD_TIME							
	0xE9	CHK_RST_TIME	R/W	0x00	CHK_RST_TIME							
	0xEA	CHK_IRST_TIME	R/W	0x00	CHK_IRST_TIME							
	0xEB	DIG_GAIN	R/W	0x00	CHK_DIG_GAIN				SENS_DIG_GAIN			
	0xEC	CHK_WAIT_TIME	R/W	0x00	CHK_WAIT_TIME							
	0xED	SENS_WAIT_TIME	R/W	0x00	SENS_WAIT_TIME							
	0xEE	CALIB_CONFIG0	R/W	0x00	RET_NUM							
0xEF	CALIB_CONFIG1	R/W	0x00	PRECAL_PERIOD				DRIFT_SIN_NUM				
Control	0xF0	CLR_INT	R/W	0x00	-	-	-	C_PERCAL	C_WDT	C_ERCAL	C_CAL	C_INI
	0xF1	CLR_DETECT_SW_ON	R/W	0x00	C_SW7_ON	C_SW6_ON	C_SW5_ON	C_SW4_ON	C_SW3_ON	C_SW2_ON	C_SW1_ON	C_SW0_ON
	0xF2	Reserved	R/W	0x00	-							
	0xF3	CLR_DETECT_MAT_ON	R/W	0x00	C_MAT_ON	-	-	-	-	-	-	-
	0xF4	CLR_DETECT_SW_OFF	R/W	0x00	C_SW7_OFF	C_SW6_OFF	C_SW5_OFF	C_SW4_OFF	C_SW3_OFF	C_SW2_OFF	C_SW1_OFF	C_SW0_OFF
	0xF5	CLR_DETECT_SLIDER_OFF	R/W	0x00	C_SLIDER_OFF	-	-	-	-	-	-	-
	0xF6	CLR_DETECT_MAT_OFF	R/W	0x00	C_MAT_OFF	-	-	-	-	-	-	-
	0xF7	CLR_DETECT_SW_CONT	R/W	0x00	C_SW7_CONT	C_SW6_CONT	C_SW5_CONT	C_SW4_CONT	C_SW3_CONT	C_SW2_CONT	C_SW1_CONT	C_SW0_CONT
	0xF8	Reserved	R/W	0x00	-							
	0xF9	CLR_DETECT_MAT_CONT	R/W	0x00	C_MAT_CONT	-	-	-	-	-	-	-
	0xFA-FD	Reserved	R/W	0x00	-							
	0xFE	WACT	R/W	0x00	WACT							
	0xFF	CONTROL	R/W	0x00	FRCLS	CALOVF	-	CALMOD	-	CFG	CAL	ACT

[0x00-0x08 : Sensor Data]

Name: SIN_DATA
 Address: 0x00-0x08
 Description: This register shows the 8bit ADC values for each sensor.

	Bit7	Bit6	Bit5	Bit4	Bit3	Bit2	Bit1	Bit0
0x00	SD_SIN0[7]	SD_SIN0[6]	SD_SIN0[5]	SD_SIN0[4]	SD_SIN0[3]	SD_SIN0[2]	SD_SIN0[1]	SD_SIN0[0]
0x01	SD_SIN1[7]	SD_SIN1[6]	SD_SIN1[5]	SD_SIN1[4]	SD_SIN1[3]	SD_SIN1[2]	SD_SIN1[1]	SD_SIN1[0]
0x02	SD_SIN2[7]	SD_SIN2[6]	SD_SIN2[5]	SD_SIN2[4]	SD_SIN2[3]	SD_SIN2[2]	SD_SIN2[1]	SD_SIN2[0]
0x03	SD_SIN3[7]	SD_SIN3[6]	SD_SIN3[5]	SD_SIN3[4]	SD_SIN3[3]	SD_SIN3[2]	SD_SIN3[1]	SD_SIN3[0]
0x04	SD_SIN4[7]	SD_SIN4[6]	SD_SIN4[5]	SD_SIN4[4]	SD_SIN4[3]	SD_SIN4[2]	SD_SIN4[1]	SD_SIN4[0]
0x05	SD_SIN5[7]	SD_SIN5[6]	SD_SIN5[5]	SD_SIN5[4]	SD_SIN5[3]	SD_SIN5[2]	SD_SIN5[1]	SD_SIN5[0]
0x06	SD_SIN6[7]	SD_SIN6[6]	SD_SIN6[5]	SD_SIN6[4]	SD_SIN6[3]	SD_SIN6[2]	SD_SIN6[1]	SD_SIN6[0]
0x07	SD_SIN7[7]	SD_SIN7[6]	SD_SIN7[5]	SD_SIN7[4]	SD_SIN7[3]	SD_SIN7[2]	SD_SIN7[1]	SD_SIN7[0]
0x08	SD_SIN8[7]	SD_SIN8[6]	SD_SIN8[5]	SD_SIN8[4]	SD_SIN8[3]	SD_SIN8[2]	SD_SIN8[1]	SD_SIN8[0]
R/W	R	R	R	R	R	R	R	R
Initial val.	0	0	0	0	0	0	0	0

[0x10 : Interrupt factor]

Name: INTERRUPT
 Address: 0x10
 Description: This register shows the interrupt factors. Port INT outputs this register's OR operation.
 INI : Initialization finish.

It is set at the time the initialization of the MPU is completed.
 There is no corresponding mask register. The clear register is 0xF0 [0].
 It is also set when initialization by WDT occurs.

CAL : Software-calibration finish.
 It is set at the time the calibration is finished.
 The corresponding mask register is 0xDF [1], and the clear register is 0xF0 [1].

ERCAL : Self-calibration finish.
 It is set at the time the calibration is ended by an error. There are four errors in calibration (Drift calibration, Calib-error calibration, Hopping calibration, and Return calibration).The corresponding mask register is 0xDF [2] and the clear register is 0xF0 [2].

WDT : Watch Dog Timer interrupt generation
 It is WDT interruption generation time.
 If WDT interrupt occurs again without clearing WDT, HW reset will start, all are initialized, and INIT interruption of 0x10 [0] is active (low).
 The corresponding mask register is 0xDF [3], and the clear register is 0xF0 [3].
 The clearance of the WDT counter by MPU is not performed other than the time of a sense.
 Therefore, in the state of deep sleep (0xE0 [1] =0), a WDT interrupt occurs periodically.
 * The initial state is deep sleep.

PERCAL : Periodic calibration finish.
 It is set at the time the periodic calibration is completed.
 The corresponding mask register is 0xDF [4], and the clear register is 0xF0 [4].

ONDET : Detection of switch-on.
 The value of this register is '1' when it detects "ON" switch operation. This register is cleared by clearing every bit of the "Detection Switch-On" register. (0x13, 0x15)

OFFDET : Detection of switch-off.
 The value of this register is '1' when it detects "OFF" switch operation. This register is cleared by clearing every bit of the "Detection Switch-Off" register.(0x16, 0x18)

CONTDDET : Detection of continued touch.
 The value of this register is '1' when it detects a continued touch switch operation. This register is cleared by clearing every bit of the "Detection continued touch" register.(0x19, 0x1B)

	Bit7	Bit6	Bit5	Bit4	Bit3	Bit2	Bit1	Bit0
0x10	CONTDDET	OFFDET	ONDET	PERCAL	WDT	ERCAL	CAL	INI
R/W	R	R	R	R	R	R	R	R
Initial val.	0	0	0	0	0	0	0	0

[0x11 : Sensor State]

Name: SIN_STATE

Address: 0x11

Description: This register indicates the state of each sensor.

1 : Switch-on.(Register "SIN" > Register "ON") 0 : switch-off. (Register "SIN" < Register "OFF")

	Bit7	Bit6	Bit5	Bit4	Bit3	Bit2	Bit1	Bit0
0x11	SIN7_STAT	SIN6_STAT	SIN5_STAT	SIN4_STAT	SIN3_STAT	SIN2_STAT	SIN1_STAT	SIN0_STAT
R/W	R	R	R	R	R	R	R	R
Initial val.	0	0	0	0	0	0	0	0

[0x13, 0x15 : Detection Switch-On]

Name: DETECT_ON

Address: 0x13, 0x15

Description: This register indicates the transition from Off state to On state of every switch.

Since SW 0-7 supports multiple presses, each switch has bit recognition. And the matrix key does not support multiple detection, so matrix switch is indicated by 1 bit for ON detection (MAT) and 4 bits (KEY switch). Logical OR of each SW and MAT will be ONDET interrupt source register.

1: Detect On. 0: No detect.

	Bit7	Bit6	Bit5	Bit4	Bit3	Bit2	Bit1	Bit0
0x13	SW7_ON	SW6_ON	SW5_ON	SW4_ON	SW3_ON	SW2_ON	SW1_ON	SW0_ON
0x15	MAT_ON	-	-	-	KEY_ON[3]	KEY_ON[2]	KEY_ON[1]	KEY_ON[0]
R/W	R	R	R	R	R	R	R	R
Initial val.	0	0	0	0	0	0	0	0

[0x14 : Detection slider On]

Name: DETECT_SLIDER_ON

Address: 0x14

Description: SLIDER_ON: The value of this register is "1" when SLIDER is detected.

1: Detect On. 0: No detect.

SLIDER_CNT[6:0] : The detected amount of movement is shown in 2's complement. The amount of movement detected in order of SIN0→SIN1→SIN2→……→SIN7 is expressed by a positive value, and the amount of the movement detected in a reverse order is expressed by a negative value. The amount of the movement is 2 when center of gravity moves to the next sensor, and when center of gravity comes between 2 sensors, the amount of the movement is 1. It loops when the range where the detected amount of movement that can be shown is exceeded. The next of 63(0111111) become -64(1000000).

	Bit7	Bit6	Bit5	Bit4	Bit3	Bit2	Bit1	Bit0
0x14	SLIDER_ON	SLIDER_CNT[6]	SLIDER_CNT[5]	SLIDER_CNT[4]	SLIDER_CNT[3]	SLIDER_CNT[2]	SLIDER_CNT[1]	SLIDER_CNT[0]
R/W	R	R	R	R	R	R	R	R
Initial val.	0	0	0	0	0	0	0	0

[0x16, 0x18 : Detection Switch-Off]

Name: DETECT_OFF

Address: 0x16, 0x18

Description: This register indicates the transition from On state to Off state of every switch.

Since SW 0-7 supports multiple presses, each switch has bit recognition. And the matrix key does not support multiple detection, so matrix switch is indicated by 1 bit for ON detection (MAT) and 4 bits (KEY switch). Logical OR of each SW and MAT will be OFFDET interrupt source register.

1 : Detect Off. 0 : No detect.

	Bit7	Bit6	Bit5	Bit4	Bit3	Bit2	Bit1	Bit0
0x16	SW7_OFF	SW6_OFF	SW5_OFF	SW4_OFF	SW3_OFF	SW2_OFF	SW1_OFF	SW0_OFF
0x18	MAT_OFF	-	-	-	KEY_OFF[3]	KEY_OFF[2]	KEY_OFF[1]	KEY_OFF[0]
R/W	R	R	R	R	R	R	R	R
Initial val.	0	0	0	0	0	0	0	0

[0x17 : Detection slider Off]

Name: DETECT_SLIDER_OFF
 Address: 0x17

Description: It is set when IC detects that the slider is in the off state. It is necessary to clear this flag to detect. The corresponding clear register is 0xF5 [7]. 1 : Detect Off. 0 : No detect.

	Bit7	Bit6	Bit5	Bit4	Bit3	Bit2	Bit1	Bit0
0x17	SLIDER_OFF	-	-	-	-	-	-	-
R/W	R	R	R	R	R	R	R	R
Initial val.	0	0	0	0	0	0	0	0

[0x19, 0x1B : Detection continued touch]

Name: DETECT_CONT
 Address: 0x19, 0x1B

Description: This register indicates the detection of continued touch for every switch.
 Since SW 0-7 supports multiple presses, each switch has bit recognition. And the matrix key does not support multiple detection, so matrix switch is indicated by 1 bit for ON detection (MAT) and 4 bits(KEY switch). Logical OR of each SW and MAT will be CONTDDET interrupt source register.
 1 : Detect continued touch. 0 : No detect.

	Bit7	Bit6	Bit5	Bit4	Bit3	Bit2	Bit1	Bit0
0x19	SW7_CONT	SW6_CONT	SW5_CONT	SW4_CONT	SW3_CONT	SW2_CONT	SW1_CONT	SW0_CONT
0x1B	MAT_CONT	-	-	-	KEY_CONT[3]	KEY_CONT[2]	KEY_CONT[1]	KEY_CONT[0]
R/W	R	R	R	R	R	R	R	R
Initial val.	0	0	0	0	0	0	0	0

[0x1C : State of IC]

Name: STATE
 Address: 0x1C

Description: This register indicates the state of IC.

CALIB : Indicates whether the IC is in calibration or not.
 1: In calibration 0: Not in calibration

INTVL : Indicates whether the IC is in Intermittent Operation or not.
 1: Intermittent Operation 0: Not in Intermittent Operation

E_CALIB : When the calibration fails for three consecutive times, it is set.
 1: Calibration Error 0: No Error

	Bit7	Bit6	Bit5	Bit4	Bit3	Bit2	Bit1	Bit0
0x1C	E_CALIB	-	-	-	-	-	INTVL	CALIB
R/W	R	-	-	-	-	-	R	R
Initial val.	0	-	-	-	-	-	0	0

[0x1E : Read register for operation check of MPU]

Name: RACT
 Address: 0x1E

Description: This register is a read register for operational check of the IC. The value written to the write register for operation check (Address is 0xFE) is copied to this register. If the write value and the read value is equal, MPU and I/F are operating normally.

	Bit7	Bit6	Bit5	Bit4	Bit3	Bit2	Bit1	Bit0
0x1E	RACT[7]	RACT[6]	RACT[5]	RACT[4]	RACT[3]	RACT[2]	RACT[1]	RACT[0]
R/W	R	R	R	R	R	R	R	R
Initial val.	0	0	0	0	0	0	0	0

[0x85, 0x8A : Software Reset]

Name: SRST

Address: 0x85, 0x8A

Description: These registers are used for hardware reset. If register 0x85=55h and register 0x8A=AAh, then a hardware reset will be done.

	Bit7	Bit6	Bit5	Bit4	Bit3	Bit2	Bit1	Bit0
0x85	SRST[7]	SRST[6]	SRST[5]	SRST[4]	SRST[3]	SRST[2]	SRST[1]	SRST[0]
0x8A	SRST[15]	SRST[14]	SRST[13]	SRST[12]	SRST[11]	SRST[10]	SRST[9]	SRST[8]
R/W	R/W	R/W	R/W	R/W	R/W	R/W	R/W	R/W
Initial val.	0	0	0	0	0	0	0	0

[0xC0 – 0xC4 : Select a setting for Gain and Threshold for “Off→On”]

Name: CFG_SIN

Address: 0xC0 – 0xC4

Description: You can set 3 values for gain and set 3 values for threshold to the “Off → On” registers of this IC.

These registers are used to select a setting for gain and threshold for every sensor. There are three available settings.

Gain : GA_SIN*[1:0] =
0x0 : Select GA0.
0x1 : Select GA1.
0x2 : Select GA2.
0x3 : Select GA0.Threshold : ON_SIN*[1:0] =
0x0 : Select ON0.
0x1 : Select ON1.
0x2 : Select ON2.
0x3 : Select ON0.

	Bit7	Bit6	Bit5	Bit4	Bit3	Bit2	Bit1	Bit0
0xC0	GA_SIN1[1]	GA_SIN1[0]	ON_SIN1[1]	ON_SIN1[0]	GA_SIN0[1]	GA_SIN0[0]	ON_SIN0[1]	ON_SIN0[0]
0xC1	GA_SIN3[1]	GA_SIN3[0]	ON_SIN3[1]	ON_SIN3[0]	GA_SIN2[1]	GA_SIN2[0]	ON_SIN2[1]	ON_SIN2[0]
0xC2	GA_SIN5[1]	GA_SIN5[0]	ON_SIN5[1]	ON_SIN5[0]	GA_SIN4[1]	GA_SIN4[0]	ON_SIN4[1]	ON_SIN4[0]
0xC3	GA_SIN7[1]	GA_SIN7[0]	ON_SIN7[1]	ON_SIN7[0]	GA_SIN6[1]	GA_SIN6[0]	ON_SIN6[1]	ON_SIN6[0]
0xC4	-	-	-	-	GA_SIN8[1]	GA_SIN8[0]	ON_SIN8[1]	ON_SIN8[0]
R/W	R/W	R/W	R/W	R/W	R/W	R/W	R/W	R/W
Initial val.	0	0	0	0	0	0	0	0

[0xC8 – 0xC9 : Value of GAIN]

Name: GA0, GA1, GA2

Address: 0xC8 – 0xC9

Description: This register is used for setting the gain of AFE. The smaller the value of GA, the higher the gain will be. You can set 3 values for gain. These values are assigned to each sensor by register GA_SIN including CFG_SIN.

The settable range : $0x1 \leq GA \leq 0xF$

	Bit7	Bit6	Bit5	Bit4	Bit3	Bit2	Bit1	Bit0
0xC8	GA1[3]	GA1[2]	GA1[1]	GA1[0]	GA0[3]	GA0[2]	GA0[1]	GA0[0]
0xC9	-	-	-	-	GA2[3]	GA2[2]	GA2[1]	GA2[0]
R/W	R/W	R/W	R/W	R/W	R/W	R/W	R/W	R/W
Initial val.	0	0	0	0	0	0	0	0

[0xCA – 0xCC : Value of the threshold for "Off → On"]

Name: ON0, ON1, ON2

Address: 0xCA – 0xCC

Description: These registers are used for setting the threshold of the “Off → On” operation. You can set 3 values for threshold. If the 8bit ADC value of each sensor (register SENS_DATA) is larger than this value, then the “Off → On” operation of the sensor is valid. These values are assigned to each sensor by register GA_SIN including ON_SIN.

The settable range : $0x00 < OFF < ON < 0xFF$

	Bit7	Bit6	Bit5	Bit4	Bit3	Bit2	Bit1	Bit0
0xCA	ON0[7]	ON0[6]	ON0[5]	ON0[4]	ON0[3]	ON0[2]	ON0[1]	ON0[0]
0xCB	ON1[7]	ON1[6]	ON1[5]	ON1[4]	ON1[3]	ON1[2]	ON1[1]	ON1[0]
0xCC	ON2[7]	ON2[6]	ON2[5]	ON2[4]	ON2[3]	ON2[2]	ON2[1]	ON2[0]
R/W	R/W	R/W	R/W	R/W	R/W	R/W	R/W	R/W
Initial val.	0	0	0	0	0	0	0	0

【0xCD : Value of the threshold for "On → Off"】

Name: OFF
 Address: 0xCD
 Description: This register is used for setting the threshold for "On → Off" operation. If the 8bit ADC value of each sensor (register SENS_DATA) is smaller than this value, then the "On → Off" operation of the sensor is enabled.
 The setting range : 0x00 < OFF < ON < 0xFF

	Bit7	Bit6	Bit5	Bit4	Bit3	Bit2	Bit1	Bit0
0xCD	-	OFF [6]	OFF [5]	OFF [4]	OFF [3]	OFF [2]	OFF [1]	OFF [0]
R/W	-	R/W	R/W	R/W	R/W	R/W	R/W	R/W
Initial val.	-	0	0	0	0	0	0	0

【0xCE :Chattering cancel】

Name: OVERSAMPLES
 Address: 0xCE
 Description: OST[3:0] : This register has the number of times of over sampling for canceling chattering in the "ON" or "OFF" operation.
 The continuous button level of over sampling frequency + three times or less is disregarded.
 If the register value is 0, then the number of times of over sampling is 1.
 Sampling rate : About 6msec.

	Bit7	Bit6	Bit5	Bit4	Bit3	Bit2	Bit1	Bit0
0xCE	OST[3]	OST[2]	OST[1]	OST[0]	-	-	-	-
R/W	R/W	R/W	R/W	R/W	-	-	-	-
Initial val.	0	0	0	0	-	-	-	-

【0xCF :Long press】

Name: CONTTIMES
 Address: 0xCF
 Description: CONTSEL : The output pattern of an interrupt generated after recognizing long press is set up.
 1 : Every continuous touch period.
 0 : First detect only.
 CONT[5:0] : Continuous touch period is about 0.036 [sec] x CONT.
 If the setting value is 0x0, continuous touch function is invalid.
 (0.036sec ≤ Continuous touch period ≤ 2.3sec)

	Bit7	Bit6	Bit5	Bit4	Bit3	Bit2	Bit1	Bit0
0xCF	CONTSEL	-	CONT[5]	CONT[4]	CONT[3]	CONT[2]	CONT[1]	CONT[0]
R/W	R/W	-	R/W	R/W	R/W	R/W	R/W	R/W
Initial val.	0	-	0	0	0	0	0	0

【0xD0, 0xD2, 0xD3 : Mask switch operation】

Name: MSK_SW_KEY
 Address: 0xD0, 0xD2, 0xD3
 Description: This register is used for masking the operation of each matrix switches and each simple switches. The masked switches are excluded from the interrupt factor. It is prohibited to assign one sensor to both matrix switch and a simple switch. Unused switches must be masked.
 1 : Masked. 0 : Unmasked.

	Bit7	Bit6	Bit5	Bit4	Bit3	Bit2	Bit1	Bit0
0xD0	MSK_SW7	MSK_SW6	MSK_SW5	MSK_SW4	MSK_SW3	MSK_SW2	MSK_SW1	MSK_SW0
0xD2	MSK_KEYH	MSK_KEYG	MSK_KEYF	MSK_KEYE	MSK_KEYD	MSK_KEYC	MSK_KEYB	MSK_KEYA
0xD3	MSK_KEYP	MSK_KEYO	MSK_KEYN	MSK_KEYM	MSK_KEYL	MSK_KEYK	MSK_KEYJ	MSK_KEYI
R/W	R/W	R/W	R/W	R/W	R/W	R/W	R/W	R/W
Initial val.	0	0	0	0	0	0	0	0

[0xD9 : Slider]

Name: EN_SLIDER
 Address: 0xD9
 Description: EN_SLID_SIN [7:0]: It is used for enabling a sensor for a slider.
 The sensor by which 1 was set is enabled as a slider. The order is SIN0, 1, 2, 3, 4, 5, 6, and 7, and the disabled sensor is skipped. For example, when only SIN1, 2, 5, and 6 are enabled, the order is SIN1, 2, 5, 6. Moreover, when SLIDER_LOOP (0xE0 2) is enabled, SIN7 and SIN0 are processed as a consecutive sensor. When touch is detected in any of the sensors operating in intermittent mode, all enabled sensors start sensing.

	Bit7	Bit6	Bit5	Bit4	Bit3	Bit2	Bit1	Bit0
0xD9	EN_SLID_SIN7	EN_SLID_SIN6	EN_SLID_SIN5	EN_SLID_SIN4	EN_SLID_SIN3	EN_SLID_SIN2	EN_SLID_SIN1	EN_SLID_SIN0
R/W	R/W	R/W	R/W	R/W	R/W	R/W	R/W	R/W
Initial val.	0	0	0	0	0	0	0	0

[0xDA : Keep intermittent sensing]

Name: KEEP_SENS_NUM
 Address: 0xDA
 Description: KEEP_SENS_NUM[7:0] : This is used for setting how long sensing operates from last intermittent operation.
 It works only in the intermittent operation.

	Bit7	Bit6	Bit5	Bit4	Bit3	Bit2	Bit1	Bit0
0xDA	KEEP_SENS_NUM[7]	KEEP_SENS_NUM[6]	KEEP_SENS_NUM[5]	KEEP_SENS_NUM[4]	KEEP_SENS_NUM[3]	KEEP_SENS_NUM[2]	KEEP_SENS_NUM[1]	KEEP_SENS_NUM[0]
R/W	R/W	R/W	R/W	R/W	R/W	R/W	R/W	R/W
Initial val.	0	0	0	0	0	0	0	0

[0xDB : Frequency of normal sensing during check sensing]

Name: UNIT_SENS_NUM
 Address: 0xDB
 Description: UNIT_SENS_NUM[3:0] : It is used to set the number of times normal sensing is done during check sensing for intermittent return. It works only in the intermittent operation. The number of times normal sensing is done is equal to the set value + 1.
 For example, when 3 is set up, it becomes check -> Normal -> Normal -> Normal -> Normal -> check -> Normal -> Normal --.

	Bit7	Bit6	Bit5	Bit4	Bit3	Bit2	Bit1	Bit0
0xDB	-	-	-	-	UNIT_SENS_NUM [3]	UNIT_SENS_NUM [2]	UNIT_SENS_NUM [1]	UNIT_SENS_NUM [0]
R/W	R/W	R/W	R/W	R/W	R/W	R/W	R/W	R/W
Initial val.	0	0	0	0	0	0	0	0

[0xDC : Intermittent operation return threshold setting]

Name: TH_SLEEP_H
 Address: 0xDC
 Description: TH_SLEEP[15:8] : It is the upper 8 bits of the return threshold value from intermittent operation to normal operation. The lower 8 bits is register 0xDD. When the result of check sensing shifts from the median and more than this threshold value, that sensor is returned from intermittent operation and normal sensing operates.

	Bit7	Bit6	Bit5	Bit4	Bit3	Bit2	Bit1	Bit0
0xDC	TH_SLEEP[15]	TH_SLEEP[14]	TH_SLEEP[13]	TH_SLEEP[12]	TH_SLEEP[11]	TH_SLEEP[10]	TH_SLEEP[9]	TH_SLEEP[8]
R/W	R/W	R/W	R/W	R/W	R/W	R/W	R/W	R/W
Initial val.	0	0	0	0	0	0	0	0

[0xDD : Intermittent sensing return threshold setting]

Name: TH_SLEEP_L
 Address: 0xDD
 Description: TH_SLEEP[7:0] : It is the lower 8 bits of the return threshold value from intermittent operation to normal operation. Please refer to register 0xDC.

	Bit7	Bit6	Bit5	Bit4	Bit3	Bit2	Bit1	Bit0
0xDD	TH_SLEEP[7]	TH_SLEEP[6]	TH_SLEEP[5]	TH_SLEEP[4]	TH_SLEEP[3]	TH_SLEEP[2]	TH_SLEEP[1]	TH_SLEEP[0]
R/W	R/W	R/W	R/W	R/W	R/W	R/W	R/W	R/W
Initial val.	0	0	0	0	0	0	0	0

【0xDE : Sensor value offset setting】

Name: OUTPUT_OFFSET
Address: 0xDE

Description: OUTPUT_OFFSET[7:0] : The offset added to the sensor value output to SD_SIN0-SD_SIN8(0x00-0x08) is set. When the calibration is completed, these sensor values reach the value of about 0. Therefore, it is shown as 0, and doesn't acquire an accurate value when swinging to negative. When offset is added, monitoring data at the minus side and acquiring an accurate value becomes possible.

	Bit7	Bit6	Bit5	Bit4	Bit3	Bit2	Bit1	Bit0
0xDE	OUTPUT_OFFSET[7]	OUTPUT_OFFSET[6]	OUTPUT_OFFSET[5]	OUTPUT_OFFSET[4]	OUTPUT_OFFSET[3]	OUTPUT_OFFSET[2]	OUTPUT_OFFSET[1]	OUTPUT_OFFSET[0]
R/W	R/W	R/W	R/W	R/W	R/W	R/W	R/W	R/W
Initial val.	0	0	0	0	0	0	0	0

【0xDF : Mask interrupt】

Name: MSK_INTERRUPT
Address: 0xDF

Description: This register is for masking the interrupt factor. The masked interrupt factor is not shown on the register "Interrupt factor (address 0x10)", so it does not affect the output port INT.
1 : Masked. 0 : Unmasked.

MSK_CAL : Mask for Software-calibration finish.

This bit is used for masking the interrupt of Software-calibration finish (the bit CAL in the register INTERRUPT(address 0x10)).

MSK_ERCAL : Mask for Self-calibration finish.

This bit is used for masking the interrupt of Self-calibration finish (the bit ERCAL in the register INTERRUPT(address 0x10)).

MSK_WDT : Mask for watch dog timer.

This bit is used for masking the interrupt of initialization by WDT.
WDT of register interrupt factor (address 0x10) is masked.

MSK_PERCAL : Mask for Periodic calibration finish.

This bit is used for masking the interrupt of Periodic calibration finish (the bit PERCAL in the register INTERRUPT(address 0x10)).

	Bit7	Bit6	Bit5	Bit4	Bit3	Bit2	Bit1	Bit0
0xDF	-	-	-	MSK_PERCAL	MSK_WDT-	MSK_ERCAL	MSK_CAL	-
R/W	-	-	-	R/W	R/W	R/W	R/W	-
Initial val.	-	-	-	0	-0	0	0	-

【0xE0 : Operation mode setting0】

Name: MODE_CONFIG0
Address: 0xE0

Description: FIX_BASE_CYC : Sensing frequency is changed at the time of calibration failure, and returns the error occurrence time. The noise measure function is disabled.

FIX_SNS_CYC : The noise measures function to change the frequency of sensing to each sensing is invalidated.

SLID_LOOP : Process which treats CH recognized as a slider like a sensor continuous like SIN6->SIN7->SIN0 and SIN1 ->SIN0 ->SIN7 is enabled.

EN_DSLP : The main clock is stopped when the main clock is not necessary while intermittent is operating and the operating current is lowered.

EN_SLP : Intermittent operation is activated and the operating current is lowered.

	Bit7	Bit6	Bit5	Bit4	Bit3	Bit2	Bit1	Bit0
0xE0	-	-	FIX_BASE_CYC	FIX_SNS_CYC	-	SLID_LOOP	EN_DSLP	EN_SLP
R/W	R/W	R/W	R/W	R/W	R/W	R/W	R/W	R/W
Initial val.	0	0	0	0	0	0	0	0

[0xE1 : Operation mode setting1]

Name: MODE_CONFIG1
Address: 0xE1

Description: DIS_SIN8: Disables SIN8 for noise detection. Since sensing is not done when it is disabled, the operating current decreases.
RERCAL_DIS : Disables regular calibration.
RET_DIS : Disables return calibration. 1: disable function.
HOP_DIS : Disables hopping calibration. 1: disable function.
ERROR_DIS : Disables error calibration. 1: disable function.
DRIFT_DIS : Disables drift calibration. 1: disable function.

	Bit7	Bit6	Bit5	Bit4	Bit3	Bit2	Bit1	Bit0
0xE1	DIS_SIN8	-	-	RERCAL_DIS	RET_DIS	HOP_DIS	ERROR_DIS	DRIFT_DIS
R/W	R/W	R/W	R/W	R/W	R/W	R/W	R/W	R/W
Initial val.	0	0	0	0	0	0	0	0

[0xE2 : Effective sensor setting]

Name: EN_SIN
Address: 0xE2

Description: EN_SIN[7:0]: Enables sensors
The sensor by which 1 was set is enabled. Sensing is done only when the sensor is enabled. Disabling unnecessary sensors can lower current consumption.

	Bit7	Bit6	Bit5	Bit4	Bit3	Bit2	Bit1	Bit0
0xE2	EN_SIN[7]	EN_SIN[6]	EN_SIN[5]	EN_SIN[4]	EN_SIN[3]	EN_SIN[2]	EN_SIN[1]	EN_SIN[0]
R/W	R/W	R/W	R/W	R/W	R/W	R/W	R/W	R/W
Initial val.	0	0	0	0	0	0	0	0

[0xE3 : Data compare frequency setting]

Name: SENS_NUM
Address: 0xE3

Description: SENS_NUM[7:0] : The number of times data comparison is performed during 1 time of sensing .
Increasing the value also increases the accuracy but time and its current consumption also increases.

	Bit7	Bit6	Bit5	Bit4	Bit3	Bit2	Bit1	Bit0
0xE3	SENS_NUM[7]	SENS_NUM[6]	SENS_NUM[5]	SENS_NUM[4]	SENS_NUM[3]	SENS_NUM[2]	SENS_NUM[1]	SENS_NUM[0]
R/W	R/W	R/W	R/W	R/W	R/W	R/W	R/W	R/W
Initial val.	0	0	0	0	0	0	0	0

[0xE4 : Normal sensing timing setting 1]

Name: SENS_RD_TIME
Address: 0xE4

Description: SENS_RD_TIME [7:0] : Comparator initial waiting time at normal sensing.
The time of one normal sensing increases by increasing the value.

	Bit7	Bit6	Bit5	Bit4	Bit3	Bit2	Bit1	Bit0
0xE4	SENS_RD_TIME[7]	SENS_RD_TIME[6]	SENS_RD_TIME[5]	SENS_RD_TIME[4]	SENS_RD_TIME[3]	SENS_RD_TIME[2]	SENS_RD_TIME[1]	SENS_RD_TIME[0]
R/W	R/W	R/W	R/W	R/W	R/W	R/W	R/W	R/W
Initial val.	0	0	0	0	0	0	0	0

[0xE5 : Normal sensing timing setting 2]

Name: SENS_RST_TIME
 Address: 0xE5
 Description: SENS_RST_TIME [7:0] : Setting of normal sensing at impressed time.
 The time of normal sensing increases by increasing the value.

	Bit7	Bit6	Bit5	Bit4	Bit3	Bit2	Bit1	Bit0
0xE5	SENS_RST_TIME[7]	SENS_RST_TIME[6]	SENS_RST_TIME[5]	SENS_RST_TIME[4]	SENS_RST_TIME[3]	SENS_RST_TIME[2]	SENS_RST_TIME[1]	SENS_RST_TIME[0]
R/W	R/W	R/W	R/W	R/W	R/W	R/W	R/W	R/W
Initial val.	0	0	0	0	0	0	0	0

[0xE6 : Normal sensing timing setting 3]

Name: SENS_IRST_TIME
 Address: 0xE6
 Description: SENS_IRST_TIME [7:0] : Setting of normal sensing at initial impressed time.
 The time of normal sensing increases by increasing the value.

	Bit7	Bit6	Bit5	Bit4	Bit3	Bit2	Bit1	Bit0
0xE6	SENS_IRST_TIME[7]	SENS_IRST_TIME[6]	SENS_IRST_TIME[5]	SENS_IRST_TIME[4]	SENS_IRST_TIME[3]	SENS_IRST_TIME[2]	SENS_IRST_TIME[1]	SENS_IRST_TIME[0]
R/W	R/W	R/W	R/W	R/W	R/W	R/W	R/W	R/W
Initial val.	0	0	0	0	0	0	0	0

[0xE7 : Datacompare frequency setting at check sensing]

Name: CHK_NUM
 Address: 0xE7
 Description: CHK_NUM[7:0] : Frequency of data comparison by check sensing and one time of calibration sensing.
 Increasing the value also increases the accuracy but sensing time and its current consumption also increases.

	Bit7	Bit6	Bit5	Bit4	Bit3	Bit2	Bit1	Bit0
0xE7	CHK_NUM[7]	CHK_NUM[6]	CHK_NUM[5]	CHK_NUM[4]	CHK_NUM[3]	CHK_NUM[2]	CHK_NUM[1]	CHK_NUM[0]
R/W	R/W	R/W	R/W	R/W	R/W	R/W	R/W	R/W
Initial val.	0	0	0	0	0	0	0	0

[0xE8 : Check sensing timing setting1]

Name: CHK_RD_TIME
 Address: 0xE8
 Description: CHK_RD_TIME [7:0] :Setting of comparator initial waiting time for check sensing and calibration sensing.
 Increasing the value also increases the time for one sensing.

	Bit7	Bit6	Bit5	Bit4	Bit3	Bit2	Bit1	Bit0
0xE8	CHK_RD_TIME[7]	CHK_RD_TIME[6]	CHK_RD_TIME[5]	CHK_RD_TIME[4]	CHK_RD_TIME[3]	CHK_RD_TIME[2]	CHK_RD_TIME[1]	CHK_RD_TIME[0]
R/W	R/W	R/W	R/W	R/W	R/W	R/W	R/W	R/W
Initial val.	0	0	0	0	0	0	0	0

[0xE9 : Check sensing timing setting 2]

Name: CHK_RST_TIME
 Address: 0xE9
 Description: CHK_RST_TIME [7:0] : Setup time setting for check sensing and calibration sensing.
 Increasing the value also increases the time for one sensing.

	Bit7	Bit6	Bit5	Bit4	Bit3	Bit2	Bit1	Bit0
0xE9	CHK_RST_TIME[7]	CHK_RST_TIME[6]	CHK_RST_TIME[5]	CHK_RST_TIME[4]	CHK_RST_TIME[3]	CHK_RST_TIME[2]	CHK_RST_TIME[1]	CHK_RST_TIME[0]
R/W	R/W	R/W	R/W	R/W	R/W	R/W	R/W	R/W
Initial val.	0	0	0	0	0	0	0	0

【0xEA : Check sensing timing setting 3】

Name: CHK_IRST_TIME

Address: 0xEA

Description: CHK_IRST_TIME [7:0] : Setup time setting for check sensing and calibration sensing. The value also increases the time for one sensing.

	Bit7	Bit6	Bit5	Bit4	Bit3	Bit2	Bit1	Bit0
0xEA	CHK_IRST_TIME[7]	CHK_IRST_TIME[6]	CHK_IRST_TIME[5]	CHK_IRST_TIME[4]	CHK_IRST_TIME[3]	CHK_IRST_TIME[2]	CHK_IRST_TIME[1]	CHK_IRST_TIME[0]
R/W	R/W	R/W	R/W	R/W	R/W	R/W	R/W	R/W
Initial val.	0	0	0	0	0	0	0	0

【0xEB : Digital gain setting】

Name: DIG_GAIN

Address: 0xEB

Description: CHK_DIG_GAIN [3:0]: The digital gain result at the time of check sensing and calibration sensing is shifted to the right only by the set value. The sensor value obtained with 0x00-0x08 is the value after the digital gain is applied.

SENS_DIG_GAIN [3:0]: Digital gain at the time of normal sensing

The result is shifted to the right only by the set value.

Moreover, the sensor value obtained with 0x00-0x08 is the value after the digital gain is applied.

	Bit7	Bit6	Bit5	Bit4	Bit3	Bit2	Bit1	Bit0
0xEB	CHK_DIG_GAIN[3]	CHK_DIG_GAIN[2]	CHK_DIG_GAIN[1]	CHK_DIG_GAIN[0]	SENS_DIG_GAIN[3]	SENS_DIG_GAIN[2]	SENS_DIG_GAIN[1]	SENS_DIG_GAIN[0]
R/W	R/W	R/W	R/W	R/W	R/W	R/W	R/W	R/W
Initial val.	0	0	0	0	0	0	0	0

【0xEC : Setting at intermittent operation time】

Name: CHK_WAIT_TIME

Address: 0xEC

Description: CHK_WAIT_TIME [7:0] : It decides the execution interval between the check sensing and the next check sensing. Corresponds to check intervals when all sensors are judged OFF through touch judgement of check sensing. Check interval = (set value + 1) X 4 ms

When ON judgment is done, the check sensing interval is decided by the sensing execution interval.

Intermittent sensing is applied only when it is enabled.

	Bit7	Bit6	Bit5	Bit4	Bit3	Bit2	Bit1	Bit0
0xEC	CHK_WAIT_TIME[7]	CHK_WAIT_TIME[6]	CHK_WAIT_TIME[5]	CHK_WAIT_TIME[4]	CHK_WAIT_TIME[3]	CHK_WAIT_TIME[2]	CHK_WAIT_TIME[1]	CHK_WAIT_TIME[0]
R/W	R/W	R/W	R/W	R/W	R/W	R/W	R/W	R/W
Initial val.	0	0	0	0	0	0	0	0

【0xED : Setting at normal sensing waiting time】

Name: SENS_WAIT_TIME

Address: 0xED

Description: SENS_WAIT_TIME [7:0] : Waiting time until the next sensing starts.

Normal sensing interval = set value x 4 ms

When 0 is set, the next sensing starts after the MPU calculation ends.

	Bit7	Bit6	Bit5	Bit4	Bit3	Bit2	Bit1	Bit0
0xE0	SENS_WAIT_TIME[7]	SENS_WAIT_TIME[6]	SENS_WAIT_TIME[5]	SENS_WAIT_TIME[4]	SENS_WAIT_TIME[3]	SENS_WAIT_TIME[2]	SENS_WAIT_TIME[1]	SENS_WAIT_TIME[0]
R/W	R/W	R/W	R/W	R/W	R/W	R/W	R/W	R/W
Initial val.	0	0	0	0	0	0	0	0

[0xEE : Calibration setting 0]

Name: CALIB_CONFIG0
 Address: 0xEE
 Description: RET_NUM[7:0] : Frequency setting for Calibration
 The return calibration starts when the sensing that touch detection is not performed and it is operated continuously more than the setting value after returning from intermittent operation to normal operation.

	Bit7	Bit6	Bit5	Bit4	Bit3	Bit2	Bit1	Bit0
0xEE	RET_NUM[7]	RET_NUM[6]	RET_NUM[5]	RET_NUM[4]	RET_NUM[3]	RET_NUM[2]	RET_NUM[1]	RET_NUM[0]
R/W	R/W	R/W	R/W	R/W	R/W	R/W	R/W	R/W
Initial val.	0	0	0	0	0	0	0	0

[0xEF : Calibration setting 1]

Name: CALIB_CONFIG1
 Address: 0xEF
 Description: PRECAL_PERIOD [7:4]: Setting at cyclic calibration execution intervals
 When either of the next conditions is filled, a cyclic calibration is executed.
 Sleep function disabled and (setting value +1) x 500 >= the number of sensing
 Sleep function enabled and (setting value +1) x 50 >= the number of check sensing
 DRIFT_SIM_NUM[3:0]: Number of drift calibration detection sensor channels
 When the drift detected with the sensor channel is more than this setting value, the drift calibration is activated.

	Bit7	Bit6	Bit5	Bit4	Bit3	Bit2	Bit1	Bit0
0xEF	PRECAL_PERIOD [7]	PRECAL_PERIOD [6]	PRECAL_PERIOD [5]	PRECAL_PERIOD [4]	DRIFT_SIM_NUM[3]	DRIFT_SIM_NUM[2]	DRIFT_SIM_NUM[1]	DRIFT_SIM_NUM[0]
R/W	R/W	R/W	R/W	R/W	R/W	R/W	R/W	R/W
Initial val.	0	0	0	0	0	0	0	0

[0xF0 : Clear interrupt]

Name: CLR_INTERRUPT
 Address: 0xF0
 Description: Clear Interrupt Register
 C_INI : Clear Interrupt of Initialization finish.
 Clears the INI interrupt by writing '0' in this register.
 C_CAL : Clear Interrupt of Software-calibration finish.
 Clears the CAL interrupt by writing '0' in this register.
 C_ERCAL : Clear Interrupt of Self-calibration finish.
 Clears the ERCAL interrupt by writing '0' in this register.
 C_WDT : '0' is set when clearing the bit WDT of the interrupt factor register.
 C_PERCAL : Clear Interrupt of Periodic calibration finish.
 Clears the PERCAL interrupt by writing '0' in this register.

	Bit7	Bit6	Bit5	Bit4	Bit3	Bit2	Bit1	Bit0
0xF0	-	-	-	C_PERCAL	C_WDT	C_ERCAL	C_CAL	C_INI
R/W	-	-	-	R/W	R/W	R/W	R/W	R/W
Initial val.	-	-	-	0	0	0	0	0

[0xF1, 0xF3 : Clear Switch-ON]

Name: CLR_DETECT_ON
 Address: 0xF1, 0xF3
 Description: DETECT_ON Clear Register. Clear the DETECT_ON by writing '0' in these registers. If you write '1', the operation is disabled. SW 0-15 has individual clear bit because SW 0-15 supports multiple presses. The matrix key's DETECT_ON clear bit is 1bit for MAT because the matrix key does not support multiple press.
 1 : Invalid. 0 :Clear.

	Bit7	Bit6	Bit5	Bit4	Bit3	Bit2	Bit1	Bit0
0xF1	C_SW7_ON	C_SW6_ON	C_SW5_ON	C_SW4_ON	C_SW3_ON	C_SW2_ON	C_SW1_ON	C_SW0_ON
0xF3	C_MAT_ON	-	-	-	-	-	-	-
R/W	R/W	R/W	R/W	R/W	R/W	R/W	R/W	R/W
Initial val.	0	0	0	0	0	0	0	0

[0xF4, 0xF6 : Clear Switch-OFF]

Name: CLR_DETECT_OFF
 Address: 0xF4, 0xF6

Description: DETECT_OFF Clear Register. Clears the DETECT_OFF by writing '0' in these registers. If you write '1', the operation is disabled. SW 0-7 has individual clear bit because SW 0-7 supports multiple press. The matrix key's DETECT_OFF clear bit is 1bit for MAT because the matrix key does not support multiple press.
 1 : Invalid. 0 :Clear.

	Bit7	Bit6	Bit5	Bit4	Bit3	Bit2	Bit1	Bit0
0xF4	C_SW7_OFF	C_SW6_OFF	C_SW5_OFF	C_SW4_OFF	C_SW3_OFF	C_SW2_OFF	C_SW1_OFF	C_SW0_OFF
0xF6	C_MAT_OFF	-	-	-	-	-	-	-
R/W	R/W	R/W	R/W	R/W	R/W	R/W	R/W	R/W
Initial val.	0	0	0	0	0	0	0	0

[0xF5 : Slider Off recognition clear]

Name: CLR_DETECT_SLIDER_OFF
 Address: 0xF5

Description: C_SLIDER_OFF: Clear Slider off detection flag
 SLIDER_OFF (0x17 7) is cleared by writing 0. The next slider is not detected until this flag is cleared.

	Bit7	Bit6	Bit5	Bit4	Bit3	Bit2	Bit1	Bit0
0xF4	C_SLIDER_OFF	-	-	-	-	-	-	-
R/W	R/W	R/W	R/W	R/W	R/W	R/W	R/W	R/W
Initial val.	0	0	0	0	0	0	0	0

[0xF7-0xF9 : Clear continuous touch]

Name: CLR_DETECT_CONT
 Address: 0xF7-0xF9

Description: DETECT_CONT Clear Register. Clears the DETECT_CONT by writing '0' in these registers. If you write '1', the operation is disabled. SW 0-7 has individual clear bit because SW 0-7 supports multiple press. The matrix key's DETECT_CONT clear bit is 1bit for MAT because the matrix key does not support multiple press.
 1 : Invalid. 0 :Clear.

	Bit7	Bit6	Bit5	Bit4	Bit3	Bit2	Bit1	Bit0
0xF7	C_SW7_CONT	C_SW6_CONT	C_SW5_CONT	C_SW4_CONT	C_SW3_CONT	C_SW2_CONT	C_SW1_CONT	C_SW0_CONT
0xF9	C_MAT_CONT	-	-	-	-	-	-	-
R/W	R/W	R/W	R/W	R/W	R/W	R/W	R/W	R/W
Initial val.	0	0	0	0	0	0	0	0

[0xFE : Write register for operation check of MPU]

Name: WACT
 Address: 0xFE

Description: This register is a write register for operational check of the IC. The value written to this register is copied to the register for operation check (Address is 0x1E). If the write value with the read value is equal then the MPU and I/F are operating normally.

	Bit7	Bit6	Bit5	Bit4	Bit3	Bit2	Bit1	Bit0
0xFE	WACT[7]	WACT[6]	WACT[5]	WACT[4]	WACT[3]	WACT[2]	WACT[1]	WACT[0]
R/W	R/W	R/W	R/W	R/W	R/W	R/W	R/W	R/W
Initial val.	0	0	0	0	0	0	0	0

[0xFF : AFE control]

Name: CNT
 Address: 0xFF
 Description: This register is for controlling AFE.

ACT : Scan Enable :

This bit is the scan enable for sensors. 1:Normal Scan Enable. 0:Normal Scan Disable.

CAL : Act Software-calibration :

The calibration is operated by setting '1'.

CFG : Enable Configuration Value :

Writing '1' to this bit renew the values of Sensor Configuration (Address 0xC0-0xCF), Mask Configuration except for 0xDF(Address 0xD0-0xDE), Analog setting Configuration (Address 0xE0-0xEF), FRCRLS and CALOVF. Also It affect the IC's operation.

CALMOD : Select Software-calibration mode :

0: All sensors are the targets for software-calibration. If some sensor has the value more than the threshold for "Off→On", the sensors are changed to OFF, and DETECT_OFF registers are enabled. (default)
 1: Sensors with value more than the threshold for "Off→On are not included"

CALOVF : Select Self-calibration mode detected overflow :

When the periodic calibration is active, it selects whether to activate self-calibration or not to activate in the case that the sensor values are over the dynamic range of included ADC.
 0: Deactivate self-calibration (default) 1: Activate self-calibration.

FRCRLS : Select Force OFF at continued touch :

When the continued touch is active, select whether to activate force OFF or not in the case that the max value after detect continued touch minus the current sensor value is more than the threshold for "Off→On".
 0: Deactivate force OFF(default) 1:Activate force OFF.
 The continued touch sensor is changed to OFF, and DETECT_OFF register is enabled.

	Bit7	Bit6	Bit5	Bit4	Bit3	Bit2	Bit1	Bit0
0xFF	FRCRLS	CALOVF	-	CALMOD	-	CFG	CAL	ACT
R/W	R/W	R/W	-	R/W	-	R/W	R/W	R/W
Initial val.	0	0	-	0	-	0	0	0

Timing Charts

•Host interface

2-wire serial bus.
 Compatible with I2C protocol.
 Supports slave mode only.
 Slave Address = 0x5C
 Supports Standard-mode (data transfer rate is 100 kbit/s) and Fast-mode (data transfer rate is 400 kbit/s).
 Supports sequential read.

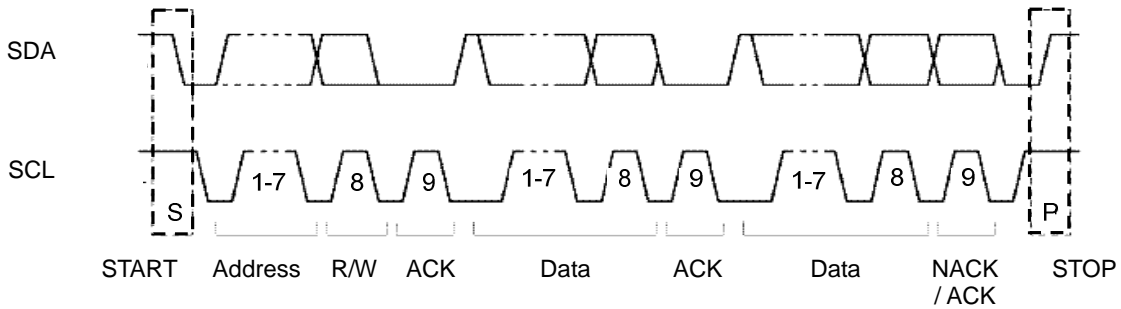

Fig 7. 2-wire serial bus data format

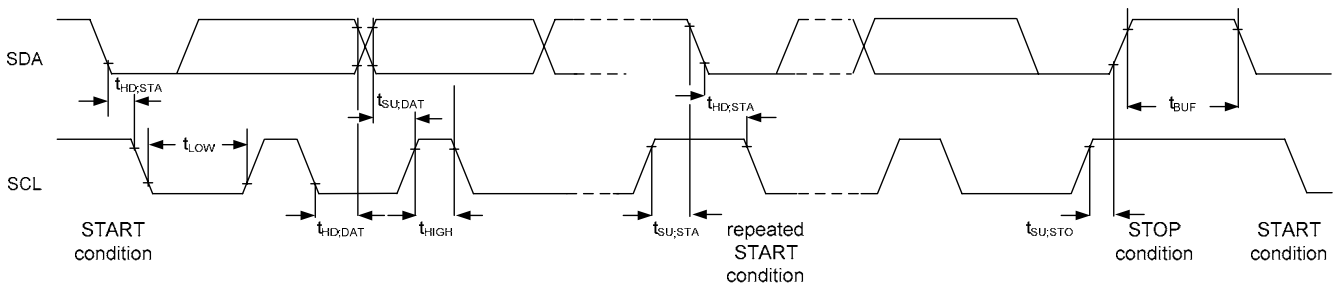
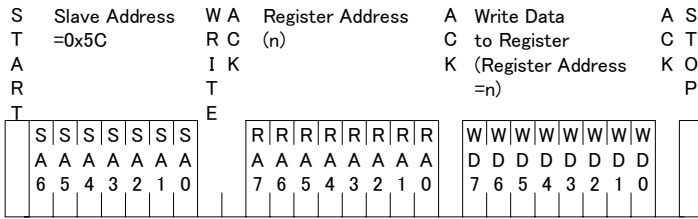

Fig 8. 2-wire serial bus timing chart

Parameter	Symbol	Standard-mode		Fast-mode		Unit
		MIN	MAX	MIN	MAX	
Hold time (repeated) START condition	f_{SCL}	0	100	0	400	kHz
LOW period of the SCL clock	$t_{HD,STA}$	4.0	-	0.6	-	μ sec
HIGH period of the SCL clock	t_{LOW}	4.7	-	1.3	-	μ sec
Data hold time	t_{HIGH}	4.0	-	0.6	-	μ sec
Data set-up time	$t_{HD,DAT}$	0.1	3.45	0.1	0.9	μ sec
Set-up time for a repeated START condition	$t_{SU,DAT}$	0.25	-	0.1	-	μ sec
Set-up time for STOP condition	$t_{SU,STA}$	4.7	-	0.6	-	μ sec
Bus free time between a STOP and START condition	$t_{SU,STO}$	4.0	-	0.6	-	μ sec
Hold time (repeated) START condition	t_{BUF}	4.7	-	1.3	-	μ sec

●Byte Write



SA : Slave Address
 RA : Register Address
 RD : Read Data
 WD : Write Data

●Random Read

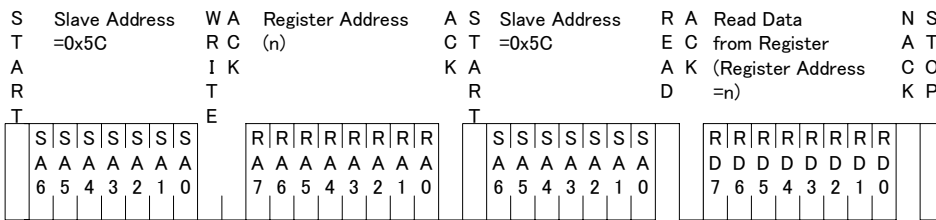

●Sequential Read

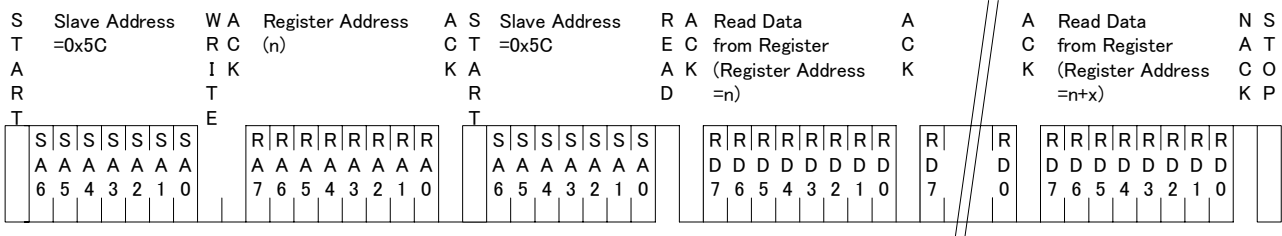

Figure 9. 2-wire serial bus protocol

Scan rate

After scanning each sensor in time series, MPU converts the detected results to switch operations. One scan rate is about 6msec at typical.

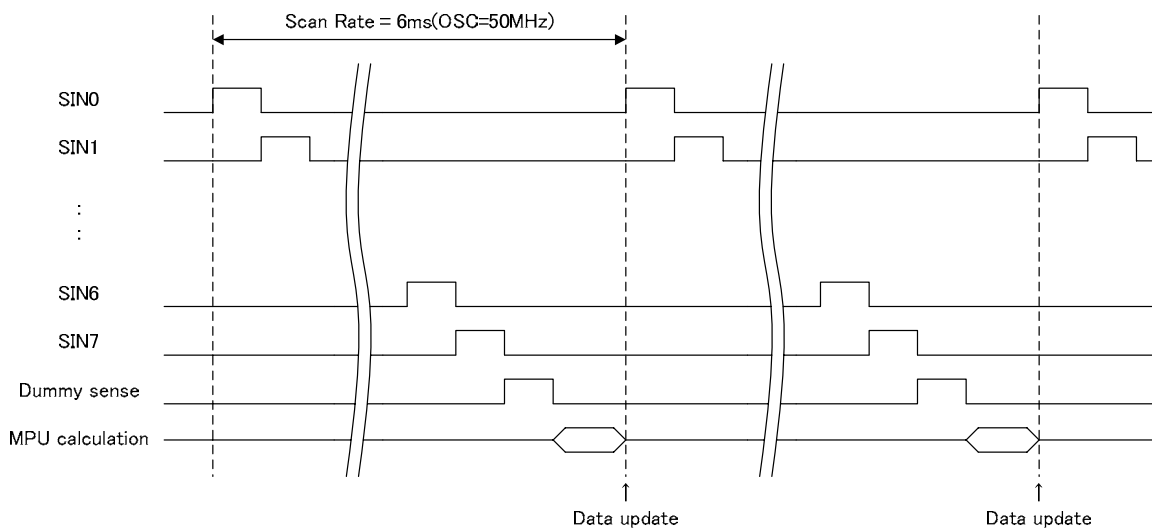

Figure 10. Timing chart of scan rate

Power on sequence

The power supply pin is only VDD. Because AVDD and DVDD are generated by a built-in LDO, there is no need for an external supply. The internal reference voltage is started up by the VDD supply, and DVDD starts up continuously. Power-on reset is released when DVDD reaches the required voltage.

Recommended value of external capacitors

C ₁	0.1μF	VDD decoupling capacitor
C ₂	1.0μF	DVDD decoupling capacitor
C ₃	2.2μF	AVDD decoupling capacitor

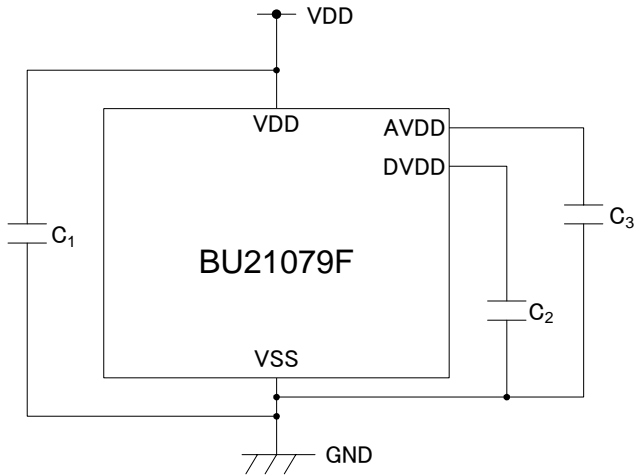

Figure 11. Arrangement of external decoupling capacitors

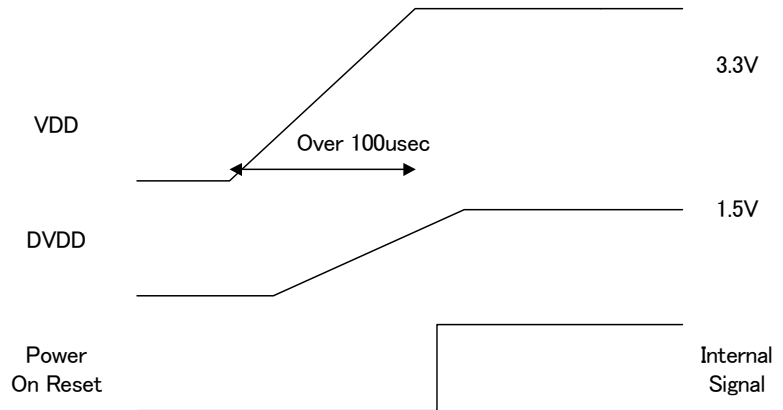

Figure 12. Power on sequence

When power-on-reset is released, MPU starts initial sequence. INT port informs the host that the initialization has been completed. After verifying if the initialization is completed, the host will need to send the command to the IC. In the case that WDTR is released as well, MPU starts initial sequence. If WDTR is released, all registers have been initialized so the host will need to resend the command to the IC.

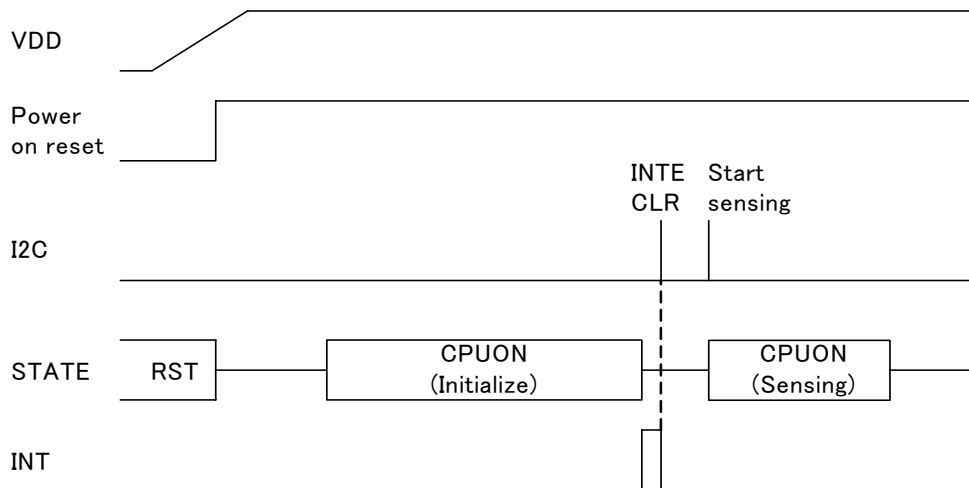

Figure 13. Timing chart of initialization

Operational mode

This IC has three operational modes, [Stop mode], [Intermittent mode], and [Normal mode].

【Stop mode】

It is the state where detection is disabled.

Detection is stopped by setting '0' to ACT of the sensor motion control register CNT (address 0xFF).

A detection process is stopped and consumption current decreases by performing the power down of AFE.

【Normal mode】

In normal mode, detection is continuous.

Sensing is started by setting '1' to ACT of the sensor motion control register CNT (address 0xFF).

Starting detection and soft calibration is operated simultaneously.

Sensing in normal mode is defined as normal sensing.

【Intermittent mode】

Detection is thinned out. If the touch detection beyond a definite period of time is not recognized, it will shift to intermittent operation. In this state, since the frequency of sensing is low, current consumption can be reduced.

Sensing in intermittent operation is defined as check sensing.

【 Normal operation 】

①An effective sensor is sensing by the SENS setting.

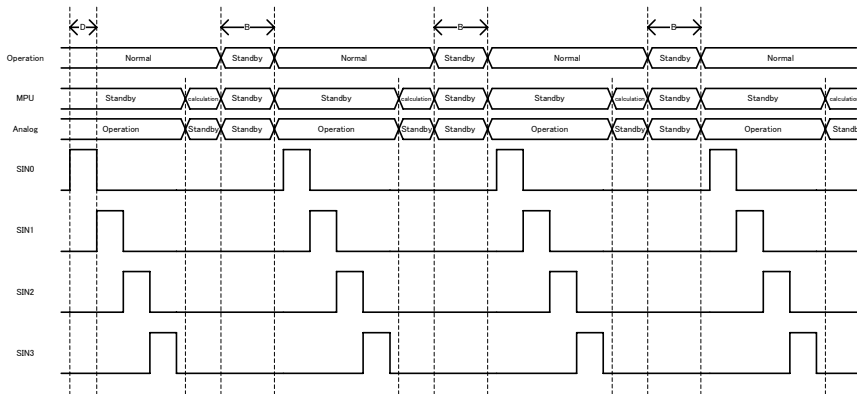

【 Intermittent operation 】

- ①All sensors are checked sensing by each CHK setting of the register.
- ②The sensor of ON judgment is done normal sensing by the check sensing result, and it uses it for the touch judgment that outputs only the result.
- ③It stands by until time equal with all channel sensing when sensors of ON judgment are less than 8 channels in the check sensing result.
- ④It stands by at time that even the next check timing was set when there is no sensor of ON judgment in the check sensing result.
- ⑤The frequency of the sensor while check sensing is operated is specified by the register. Minimum is 1 time. (A below figure is shown twice.)

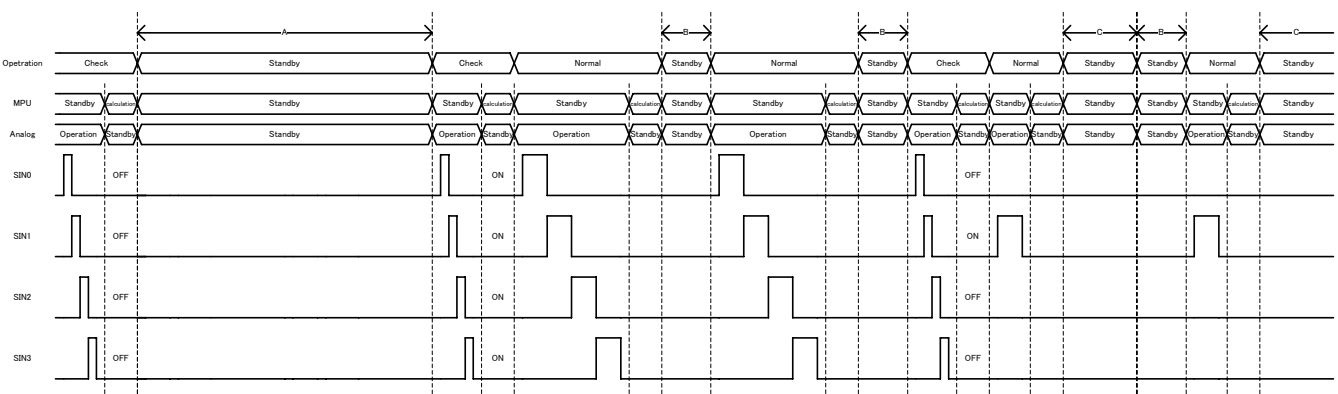

- A: Check waiting time. It is possible to set it at CHK_WAIT_TIME. (About 4 to 1024ms)
- B: Sense waiting time. It is possible to set it at SENS_WAIT_TIME. (About 0 to 1020ms)
- C: Sense adjustment time. It changes according to the number of sensors in which not sensing. (About 4ms unit)
- D: Sensing time of each sensor

Figure14. Operation sequence of normal operation and intermittent operation

Initialized operation

This IC is initialized and all registers are cleared by Power-on reset, WDT time-out reset, and Software reset command. When initialization is complete, the register INI is '1' and I/O port INT is "H". After the IC is initialized, write the configuration values to registers. After setting configuration values, the next action is sensor calibration. Set '1' to the registers ACT, CFG and CAL on Address 0xFF, and calibration sequence is performed.

The initialization process after the ROM hardware reset

- Power activation
- WDT timeout
- Software reset

Also in the case of hardware reset by any, all the register is cleared.

Since reset to MPU is also operated, MPU follows the firmware in Program ROM and initializes IC.

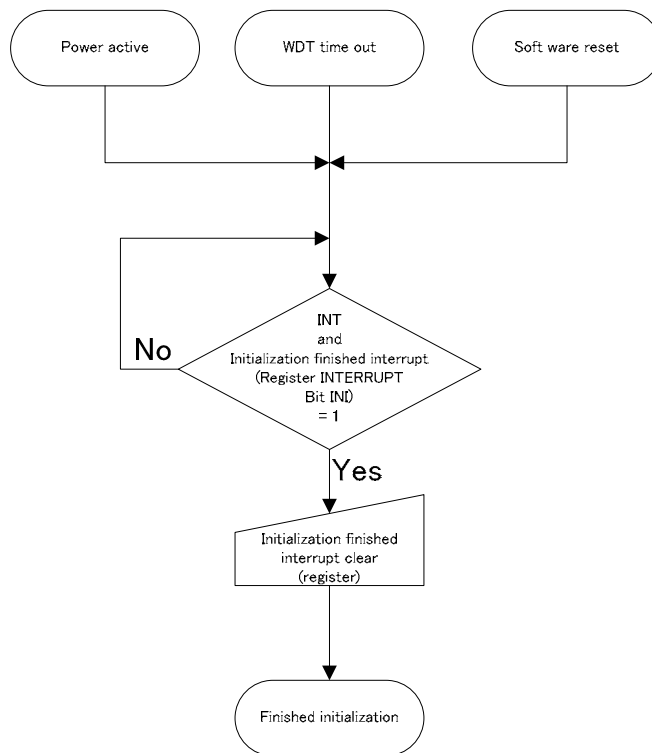

Figure15. The initialization process after hardware reset

The relation of sequence after power on and interrupt

After power on, a system reset is performed by the power-on-reset circuit inside the IC, and download of firmware from ROM is started. When downloading of the firmware is completed, the initialization is finished. Since interrupt is active, please send an interrupt clear command. Calibration starts to setup CNT (0xFF) =03h. Since interrupt is active after finishing, please send an interrupt clear command.

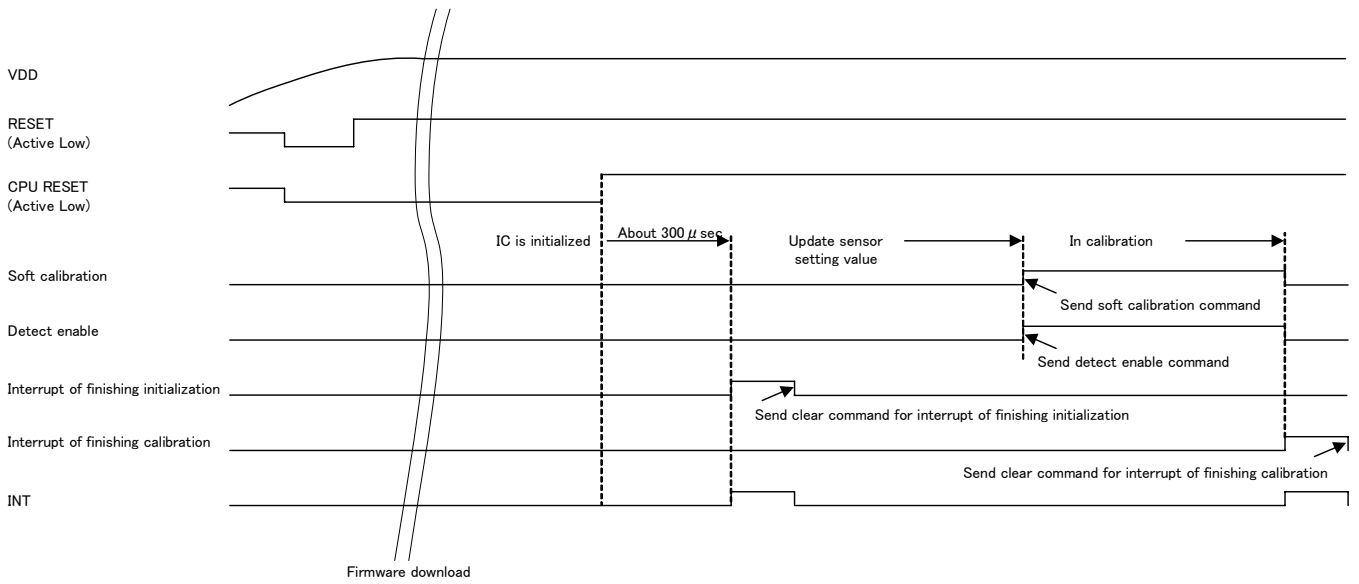

Figure16. The setting processes after a system reset and interrupt, and interrupt clear.

Calibration

There are three kinds of calibration: soft calibration, period calibration and recalibration according to error.

There are four kinds of recalibration according to error: drift calibration, calib-error calibration, hopping calibration and return calibration.

Soft calibration (CAL)

When the sensor setting value is changed, it is necessary to execute a soft calibration.

When a soft calibration ends, soft calibration end interrupt bit is '1' and INT (interrupt) pin is active.

Interrupt by soft calibration completion have mask function. (0: Off mask 1: On mask).

Bit of the soft calibration end interrupt is cleared by writing '0'.

When a soft calibration is operated, the register by the result of detecting the sensor value and the switch operation that has been detected is cleared.

IC doesn't update sensor value during calibration, therefore, the sensor operation is also disabled.

The calibration is operated by the next sampling while a soft calibration is sent during the sensor sampling.

0xFF(CALMOD) can set soft calibration execution for ON detection sensor in touch.

Period calibration (PERCAL)

The execution of self calibration can be selected at each passage at a fixed time. The selection of the execution/non-execution selects registers 0xE1[4] (PERCAL_DIS 0: Execute period calibration, 1: disable period calibration)

Calibration is not done for ON detection sensor in touch even when the period calibration is executed.

When the finger does not touch the sensor, the calibration is executed.

Whenever the period calibration is executed, an interrupt factor PERCAL is set '1' and INT (interrupt) pin is active.

Interrupt by period calibration completion have mask function (0: MASK Off , 1: MASK On).

Recalibration according to error (ERCAL)

When the next four situations are generated, the calibration is automatically executed. The completion of the recalibration can be identified through the INT interrupt.

The mask function is prepared in the interrupt factor recalibration completion. (0: MASK Off, 1: MASK On).

The completion interrupt bit of the recalibration is cleared by writing '0'.

1. Drift calibration

When the IC detects the drift condition, the IC activates self-calibration. When calibration is complete, the interrupt factor register CAL is '1' and I/O port INT is "H". When there is a sensor with a value more than the threshold for "Off→On", IC does not detect drift condition.

2. Calib-error calibration

When the finger is on the sensor at the calibration, the sensor base state is with the finger. Without the finger, the sensor value is under the base state value. This abnormal condition is defined to be an incorrect operation. When incorrect operation is detected, the IC activates self-calibration.

3. Hopping calibration

When the IC detects noise, the IC changes the scan rate so it does not synchronize with the noise, and the IC activates self-calibration. When calibration is complete, the Interrupt factor register CAL is '1' and I/O port INT is "H".

4. Return calibration

Though it returned to normal operation from intermittent operation, when sensing not on detected is more than the regulated frequency, self-calibration is executed, recalibration end interrupt bit become '1' and INT is output.

The frequency can be set by register 0xEE.

Matrix Switch

The cross points of the sensors which are arranged in a matrix can be assigned to individual switches. The matrix layout of the sensors is shown in Figure 17.

Each matrix switch has the registers of detected Touch (DETECT_ON) / Release (DETECT_OFF) / Hold (DETECT_COND) operations. It is recommended to mask unused matrix switches. If there are unstructured matrix switches (in the case that under 4x4 matrix layout), it is a must that the unstructured matrix switches are masked.

Matrix switches do not support multi-detect Touch/Release/Hold. The condition of acceptable matrix switch operation is that every sensor's value is under the threshold for "On→Off" and DETECT_OFF register of matrix switch is cleared. It is a must that the matrix switches that are made by the sensor assigned to a simple switch are masked.

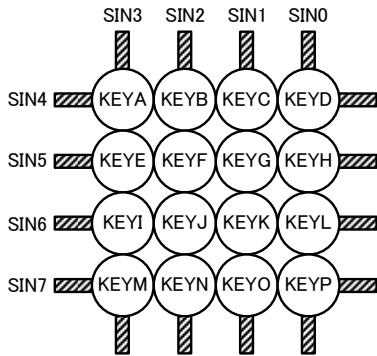

KEYA : KEY[3:0] = 0x00	KEYI : KEY[3:0] = 0x08
KEYB : KEY[3:0] = 0x01	KEYJ : KEY[3:0] = 0x09
KEYC : KEY[3:0] = 0x02	KEYK : KEY[3:0] = 0x0A
KEYD : KEY[3:0] = 0x03	KEYL : KEY[3:0] = 0x0B
KEYE : KEY[3:0] = 0x04	KEYM : KEY[3:0] = 0x0C
KEYF : KEY[3:0] = 0x05	KEYN : KEY[3:0] = 0x0D
KEYG : KEY[3:0] = 0x06	KEYO : KEY[3:0] = 0x0E
KEYH : KEY[3:0] = 0x07	KEYP : KEY[3:0] = 0x0F

Figure 17. Layout for matrix switch

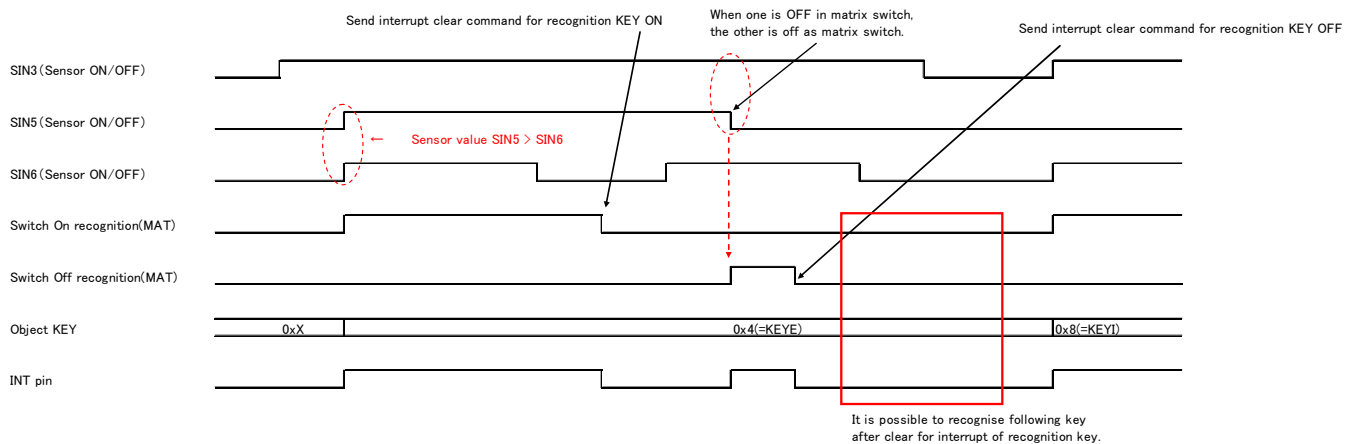

Figure 18. Interrupt of matrix switch (1)

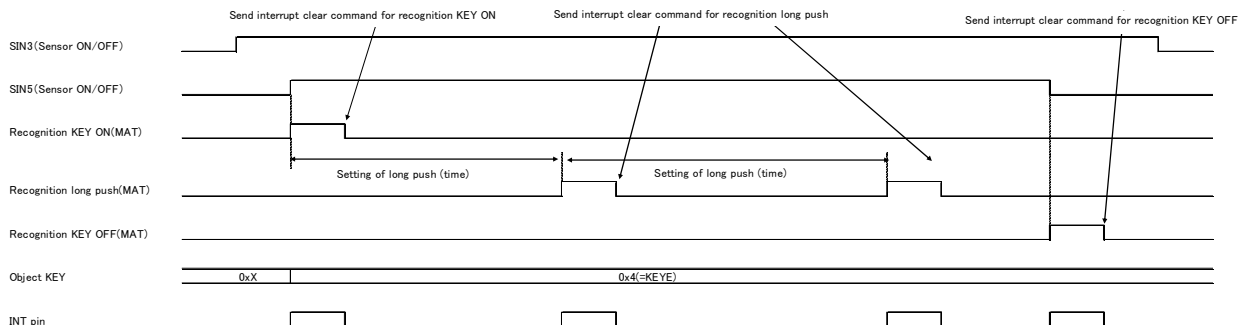
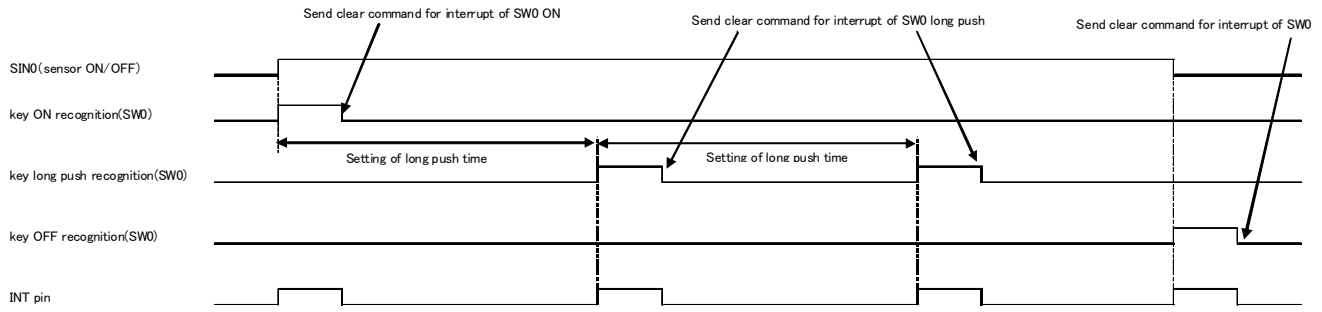

Figure 19. Interrupt of matrix switch (2)

Simple Switch

Every sensor is used for simple switch. Each simple switch has the registers of detected Touch/Release/Hold operations. Simple switches support multi-detect Touch/Release/Hold. It is possible to mask each switch.

Case1 Long push setting **CONTSEL = 1**



Case2 Long push setting **CONTSEL = 0**

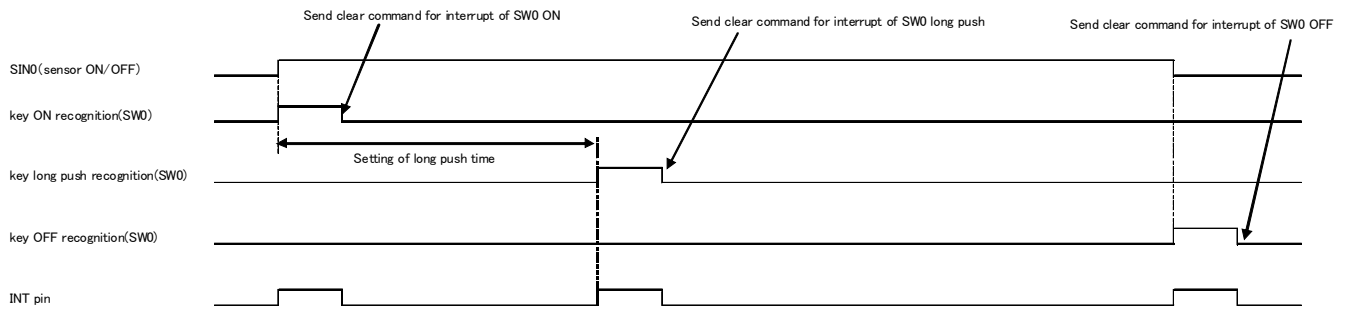

Figure 20. Interrupt of simple switch (1)

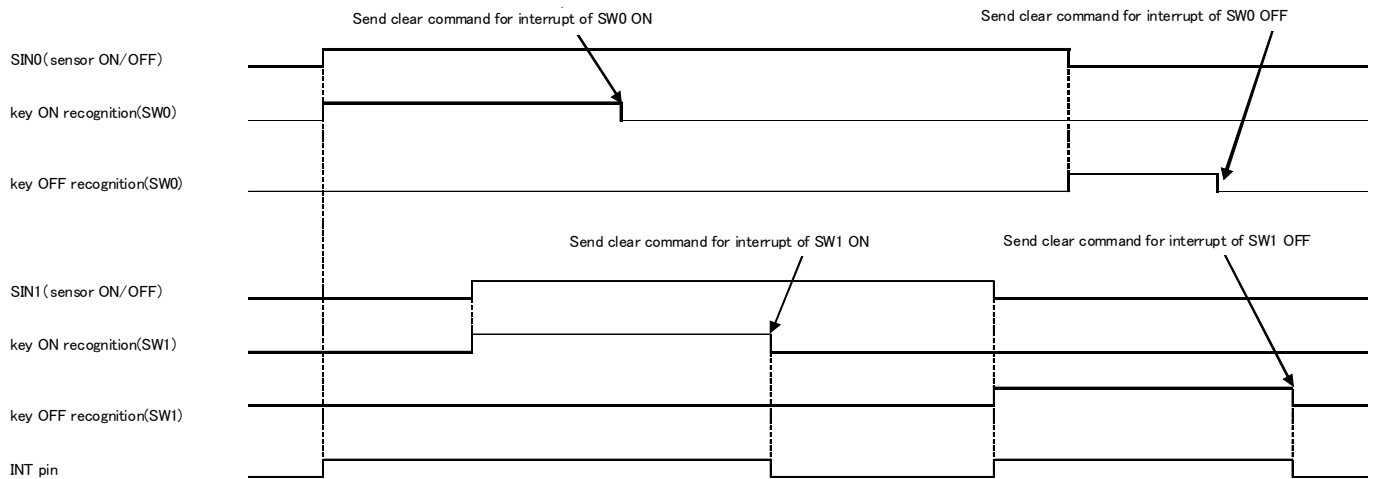

Figure 21. Interrupt of simple switch (2)

Application Examples

BU21079F offers 2 methods of switch. One method is simple switch, another method is matrix switch. The maximum number of matrix switches that BU21079F can handle is 16.

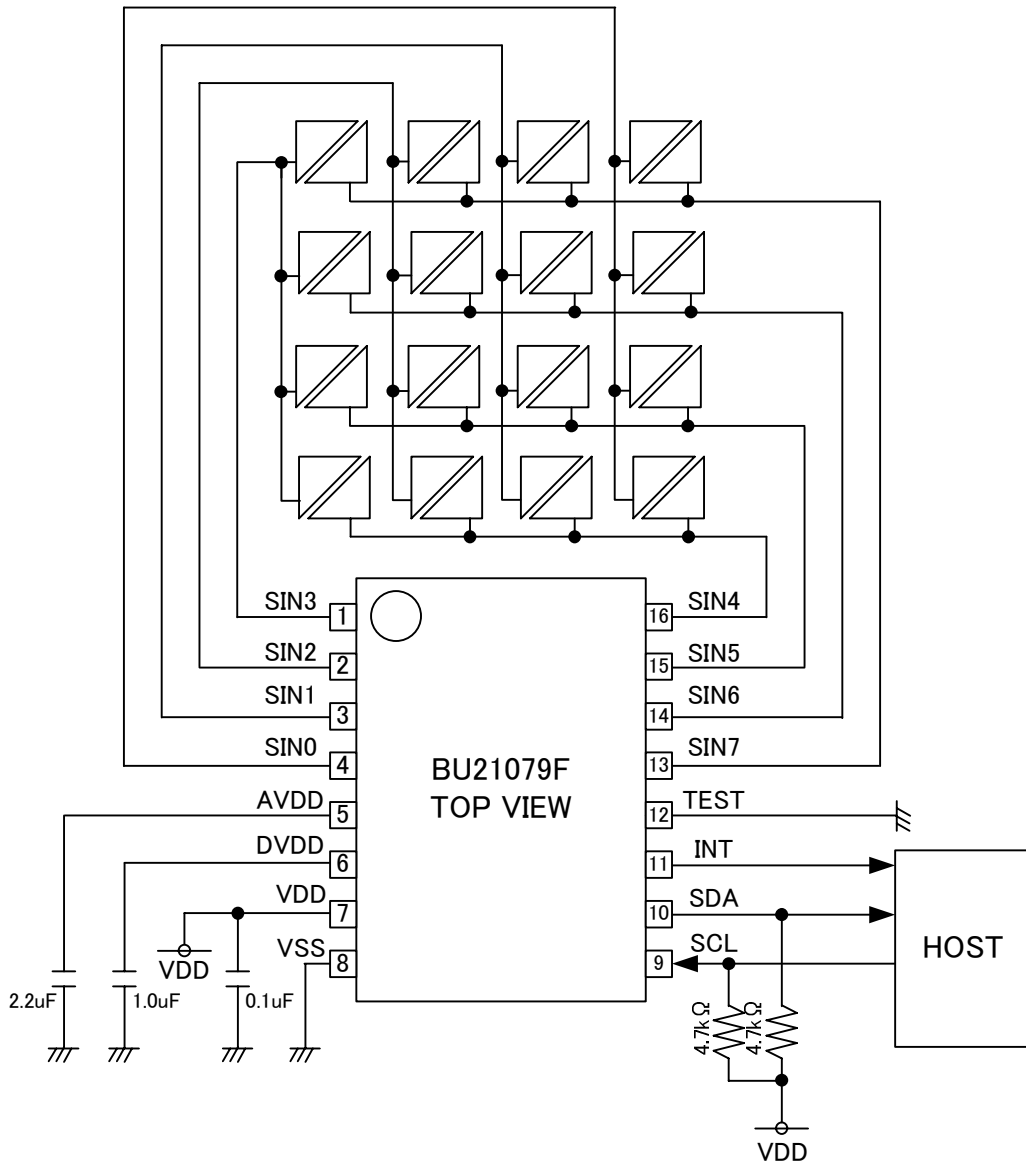

Figure 22. Application example 1. (Matrix 4 x 4 composition by BU21079F)

Operational Notes**(1) Absolute Maximum Ratings**

An excess in the absolute maximum ratings, such as supply voltage, temperature range of operating conditions, etc., can break down the device, thus making it impossible to identify the reason for breakdown such as a short circuit or an open circuit. If any special mode exceeding the absolute maximum ratings is assumed, consideration should be given and apply safety measures including the use of fuses, etc.

(2) Operating conditions

These conditions represent the range within which characteristics can be provided approximately as expected. The electrical characteristics are guaranteed under these conditions for each parameter.

(3) Reverse connection of power supply connector

The reverse connection of power supply can break down the IC. Take protective measures against the breakdown due to the reverse connection by using methods such as mounting an external diode between the power supply and the IC's power supply terminal.

(4) Power supply line

Design PCB trace to provide low impedance for the wiring between the power supply and the GND lines. In this regard, for the digital block power supply and the analog block power supply, even though these power supplies has the same level of potential, separate the power supply trace for the digital block from that of the analog block, thus suppressing the diffraction of digital noises to the analog block power supply resulting from impedance common to the trace. For the GND line, give consideration to design the trace in a similar manner.

Furthermore, for all power supply terminals of the ICs, mount a capacitor between the power supply and the GND terminal. At the same time, when using an electrolytic capacitor, be sure that the characteristics of the capacitor to be used will introduce no problem including the occurrence of capacity dropout at a low temperature, thus determining the constant.

(5) GND voltage

Set the potential of the GND terminal so that it will be maintained at the minimum in any operating state. Furthermore, ensure that no terminals are at a potential lower than the GND voltage including transient conditions.

(6) Short circuit between terminals and erroneous mounting

When mounting ICs on a PCB, pay attention to the orientation of the ICs. Erroneous mounting can break down the ICs. Furthermore, if a short circuit occurs due to foreign objects entering between terminals or between the terminal and the power supply or the GND terminal, the ICs can break down.

(7) Operation in strong electromagnetic field

Please note that using the ICs in the presence of a strong electromagnetic field can cause malfunction.

(8) Inspection with set PCB

On the inspection with the set PCB, if a capacitor is connected to a low-impedance IC terminal, the IC can suffer stress. Therefore, be sure to discharge capacitors connected to the set PCB after each process. Furthermore, in mounting or dismounting the set PCB to/from the jig for the inspection process, be sure to turn OFF the power supply and then mount the set PCB to the jig. After the completion of the inspection, be sure to turn OFF the power supply and then dismount it from the jig. In addition, for protection against static electricity, establish a ground for the assembly process and pay thorough attention to the transportation and the storage of the set PCB.

(9) Input terminals

In terms of the construction of IC, parasitic elements are inevitably formed in relation to potential. The operation of the parasitic element can cause interference with circuit operation, thus resulting in a malfunction and then breakdown of the input terminal. Therefore, pay thorough attention not to handle the input terminals, such as to apply to the input terminals a voltage lower than the GND respectively, so that any parasitic element will operate. Furthermore, do not apply a voltage to the input terminals when no power supply voltage is applied to the IC. In addition, even if the power supply voltage is applied, apply to the input terminals a voltage lower than the power supply voltage or within the guaranteed value of electrical characteristics.

(10) Ground wiring pattern

If small-signal GND and large-current GND are provided it is recommended to separate the large-current GND trace from the small-signal GND trace and establish a single ground at the reference point of the set PCB so that resistance to the wiring pattern and voltage fluctuations due to a large current will cause no fluctuations in voltages of the small-signal GND. Pay attention not to cause fluctuations in the GND wiring pattern of external parts as well.

(11) External capacitor

When using a ceramic capacitor as the external capacitor, determine the value while also considering the degradation in the nominal capacitance due to DC bias and changes in the capacitance due to temperature, etc.

(12) Rush current

When supplying power to the IC, a rush of current may occur due to the procedure and delay at power-on. Pay attention to the capacitance of the coupling capacitors and the wiring pattern width and routing of the power supply and the GND lines.

Ordering Information

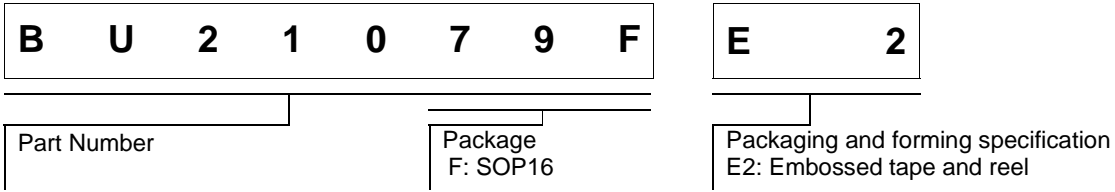

Line-up

Sensor ports	Package	Orderable Part Number
8ch	SOP16	BU21079F-E2

Physical Dimension Tape and Reel Information

SOP16

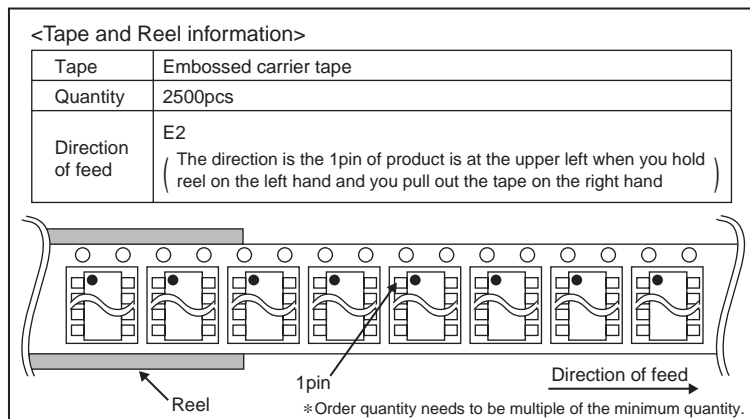
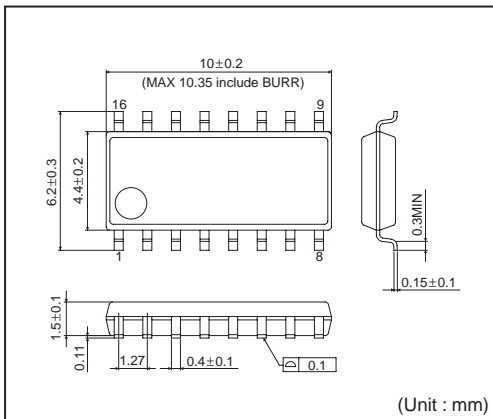

Marking Diagrams (TOP VIEW)

SOP16 (TOP VIEW)

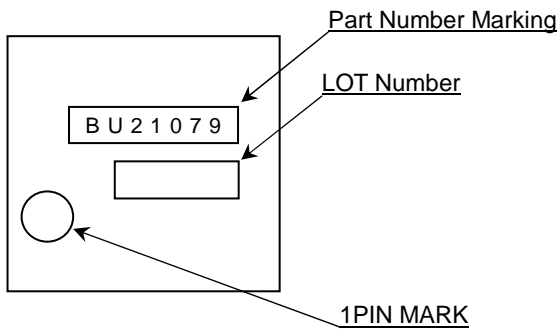

Revision History

Date	Revision	Changes
2013.9.25	Rev.001	New
—	—	—

Notice

Precaution on using ROHM Products

- Our Products are designed and manufactured for application in ordinary electronic equipments (such as AV equipment, OA equipment, telecommunication equipment, home electronic appliances, amusement equipment, etc.). If you intend to use our Products in devices requiring extremely high reliability (such as medical equipment ^(Note 1), transport equipment, traffic equipment, aircraft/spacecraft, nuclear power controllers, fuel controllers, car equipment including car accessories, safety devices, etc.) and whose malfunction or failure may cause loss of human life, bodily injury or serious damage to property ("Specific Applications"), please consult with the ROHM sales representative in advance. Unless otherwise agreed in writing by ROHM in advance, ROHM shall not be in any way responsible or liable for any damages, expenses or losses incurred by you or third parties arising from the use of any ROHM's Products for Specific Applications.

(Note1) Medical Equipment Classification of the Specific Applications

JAPAN	USA	EU	CHINA
CLASS III	CLASS III	CLASS II b	CLASS III
CLASS IV		CLASS III	

- ROHM designs and manufactures its Products subject to strict quality control system. However, semiconductor products can fail or malfunction at a certain rate. Please be sure to implement, at your own responsibilities, adequate safety measures including but not limited to fail-safe design against the physical injury, damage to any property, which a failure or malfunction of our Products may cause. The following are examples of safety measures:
 - Installation of protection circuits or other protective devices to improve system safety
 - Installation of redundant circuits to reduce the impact of single or multiple circuit failure
- Our Products are designed and manufactured for use under standard conditions and not under any special or extraordinary environments or conditions, as exemplified below. Accordingly, ROHM shall not be in any way responsible or liable for any damages, expenses or losses arising from the use of any ROHM's Products under any special or extraordinary environments or conditions. If you intend to use our Products under any special or extraordinary environments or conditions (as exemplified below), your independent verification and confirmation of product performance, reliability, etc. prior to use, must be necessary:
 - Use of our Products in any types of liquid, including water, oils, chemicals, and organic solvents
 - Use of our Products outdoors or in places where the Products are exposed to direct sunlight or dust
 - Use of our Products in places where the Products are exposed to sea wind or corrosive gases, including Cl₂, H₂S, NH₃, SO₂, and NO₂
 - Use of our Products in places where the Products are exposed to static electricity or electromagnetic waves
 - Use of our Products in proximity to heat-producing components, plastic cords, or other flammable items
 - Sealing or coating our Products with resin or other coating materials
 - Use of our Products without cleaning residue of flux (even if you use no-clean type fluxes, cleaning residue of flux is recommended); or Washing our Products by using water or water-soluble cleaning agents for cleaning residue after soldering
 - Use of the Products in places subject to dew condensation
- The Products are not subject to radiation-proof design.
- Please verify and confirm characteristics of the final or mounted products in using the Products.
- In particular, if a transient load (a large amount of load applied in a short period of time, such as pulse. is applied, confirmation of performance characteristics after on-board mounting is strongly recommended. Avoid applying power exceeding normal rated power; exceeding the power rating under steady-state loading condition may negatively affect product performance and reliability.
- De-rate Power Dissipation (Pd) depending on Ambient temperature (Ta). When used in sealed area, confirm the actual ambient temperature.
- Confirm that operation temperature is within the specified range described in the product specification.
- ROHM shall not be in any way responsible or liable for failure induced under deviant condition from what is defined in this document.

Precaution for Mounting / Circuit board design

- When a highly active halogenous (chlorine, bromine, etc.) flux is used, the residue of flux may negatively affect product performance and reliability.
- In principle, the reflow soldering method must be used; if flow soldering method is preferred, please consult with the ROHM representative in advance.

For details, please refer to ROHM Mounting specification

Precautions Regarding Application Examples and External Circuits

1. If change is made to the constant of an external circuit, please allow a sufficient margin considering variations of the characteristics of the Products and external components, including transient characteristics, as well as static characteristics.
2. You agree that application notes, reference designs, and associated data and information contained in this document are presented only as guidance for Products use. Therefore, in case you use such information, you are solely responsible for it and you must exercise your own independent verification and judgment in the use of such information contained in this document. ROHM shall not be in any way responsible or liable for any damages, expenses or losses incurred by you or third parties arising from the use of such information.

Precaution for Electrostatic

This Product is electrostatic sensitive product, which may be damaged due to electrostatic discharge. Please take proper caution in your manufacturing process and storage so that voltage exceeding the Products maximum rating will not be applied to Products. Please take special care under dry condition (e.g. Grounding of human body / equipment / solder iron, isolation from charged objects, setting of ionizer, friction prevention and temperature / humidity control).

Precaution for Storage / Transportation

1. Product performance and soldered connections may deteriorate if the Products are stored in the places where:
 - [a] the Products are exposed to sea winds or corrosive gases, including Cl₂, H₂S, NH₃, SO₂, and NO₂
 - [b] the temperature or humidity exceeds those recommended by ROHM
 - [c] the Products are exposed to direct sunshine or condensation
 - [d] the Products are exposed to high Electrostatic
2. Even under ROHM recommended storage condition, solderability of products out of recommended storage time period may be degraded. It is strongly recommended to confirm solderability before using Products of which storage time is exceeding the recommended storage time period.
3. Store / transport cartons in the correct direction, which is indicated on a carton with a symbol. Otherwise bent leads may occur due to excessive stress applied when dropping of a carton.
4. Use Products within the specified time after opening a humidity barrier bag. Baking is required before using Products of which storage time is exceeding the recommended storage time period.

Precaution for Product Label

QR code printed on ROHM Products label is for ROHM's internal use only.

Precaution for Disposition

When disposing Products please dispose them properly using an authorized industry waste company.

Precaution for Foreign Exchange and Foreign Trade act

Since our Products might fall under controlled goods prescribed by the applicable foreign exchange and foreign trade act, please consult with ROHM representative in case of export.

Precaution Regarding Intellectual Property Rights

1. All information and data including but not limited to application example contained in this document is for reference only. ROHM does not warrant that foregoing information or data will not infringe any intellectual property rights or any other rights of any third party regarding such information or data. ROHM shall not be in any way responsible or liable for infringement of any intellectual property rights or other damages arising from use of such information or data.:
2. No license, expressly or implied, is granted hereby under any intellectual property rights or other rights of ROHM or any third parties with respect to the information contained in this document.

Other Precaution

1. This document may not be reprinted or reproduced, in whole or in part, without prior written consent of ROHM.
2. The Products may not be disassembled, converted, modified, reproduced or otherwise changed without prior written consent of ROHM.
3. In no event shall you use in any way whatsoever the Products and the related technical information contained in the Products or this document for any military purposes, including but not limited to, the development of mass-destruction weapons.
4. The proper names of companies or products described in this document are trademarks or registered trademarks of ROHM, its affiliated companies or third parties.

General Precaution

1. Before you use our Products, you are requested to carefully read this document and fully understand its contents. ROHM shall not be in any way responsible or liable for failure, malfunction or accident arising from the use of any ROHM's Products against warning, caution or note contained in this document.
2. All information contained in this document is current as of the issuing date and subject to change without any prior notice. Before purchasing or using ROHM's Products, please confirm the latest information with a ROHM sales representative.
3. The information contained in this document is provided on an "as is" basis and ROHM does not warrant that all information contained in this document is accurate and/or error-free. ROHM shall not be in any way responsible or liable for any damages, expenses or losses incurred by you or third parties resulting from inaccuracy or errors of or concerning such information.