

UNLESS OTHERWISE NOTED TOLERANCES ARE:

ONE PLACE DECIMALS ± .1	THREE PLACE DECIMALS ± .005	ANGLES ± 5°
TWO PLACE DECIMALS ± .01	FOUR PLACE DECIMALS ± .0020	

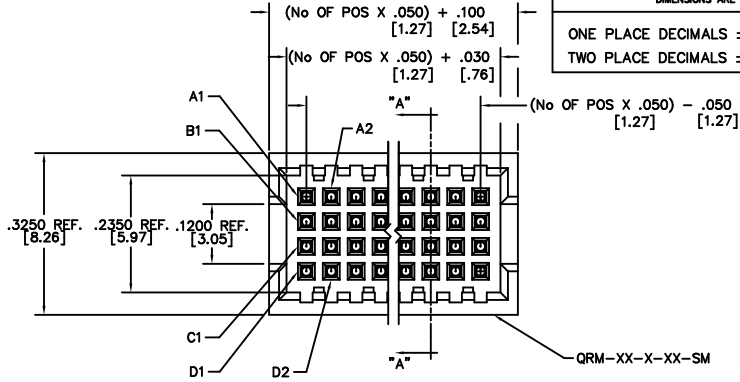

- MOLC-1XX-02-XXX-Q-XX-XX
- No OF POSITIONS
-05 THRU -50
- LEAD STYLE
-02: SURFACE MOUNT
- OPTION
-P: PICK AND PLACE PAD (USE PPP-19)
-TR: TAPE & REEL
- OPTION
-LC: LOCKING CLIP (USE LC-09-TM) (SEE NOTE 6)
- BODY SPECIFICATION
-Q: 4 ROW (USE QRM-XX-Q-01-SM)
- PLATING SPECIFICATIONS
-S: 30µ" SELECTIVE GOLD IN CONTACT AREA, MATTE TIN ON TAIL
-H: 30µ" HEAVY GOLD IN CONTACT AREA, 3µ" ON TAIL
-STL: 30µ" SELECTIVE GOLD IN CONTACT AREA, TIN/LEAD (90/10 +/-5%) TAIL
-SM: 30µ" SELECTIVE GOLD IN CONTACT AREA, MATTE TIN ON TAIL
-L: 15µ" LIGHT SELECTIVE GOLD IN CONTACT AREA, MATTE TIN ON TAIL

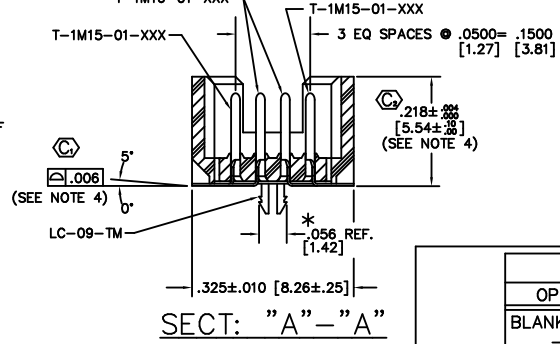
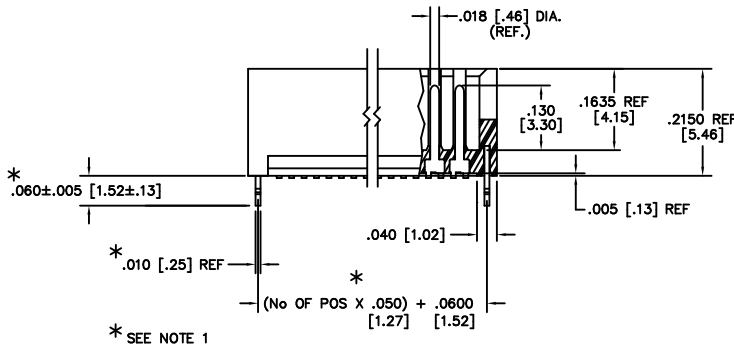
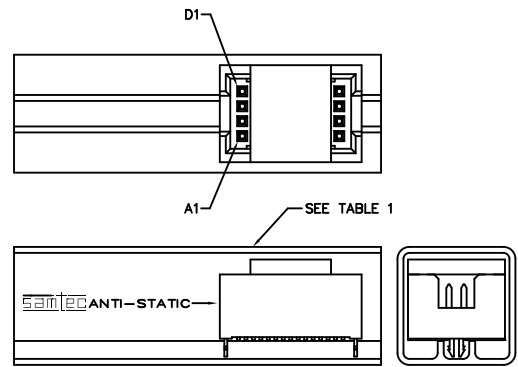
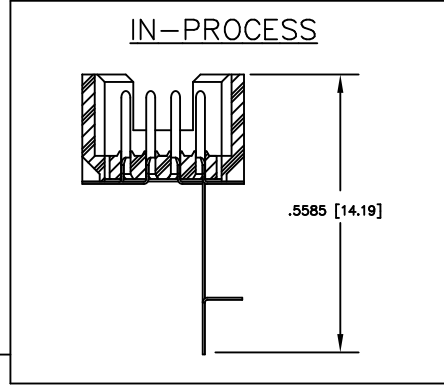
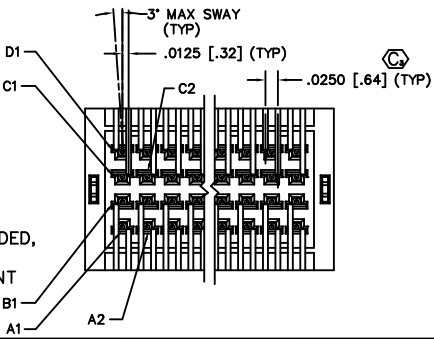

TABLE 1

OPTION	TUBE	PLUG
BLANK, -LC	PT-1-24-04-38	TP-03
-P	PT-1-24-03-38	TP-03

- NOTES:
1. DIMENSIONS PERTAIN TO -LC OPTION ONLY.
 2. INSULATOR MATERIAL: VECTRA E130
 3. NOTE DELETED
 4. DIMENSION TO BE MEASURED AT BEND OF THE LEAD, AND LEADS MUST REST ON PLASTIC RIBS.
 5. Ⓢ REPRESENTS CRITICAL DIMENSION FOR
 6. DUE TO THE HIGH AMOUNT OF INSERTION FORCE NEEDED, THE -LC OPTION IS NOT COMPATIBLE WITH AUTO PLACEMENT. SAMTEC RECOMMENDS MANUAL PLACEMENT FOR ALL ASSEMBLIES WITH THE -LC OPTION.



"A" = $\frac{(\text{NO. OF POS. X .050 [1.27]} + .100 [2.54])}{2} - .135$

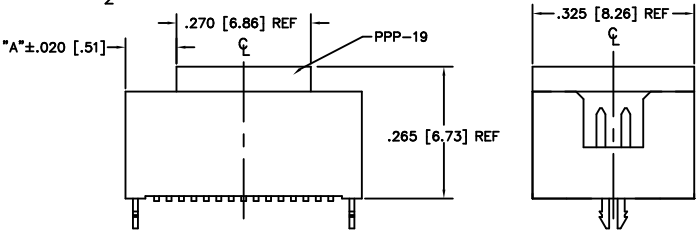

-P: PICK AND PLACE PAD

PACKAGE PARTS IN TUBE AS SHOWN

PROPRIETARY NOTE
THIS DOCUMENT CONTAINS INFORMATION CONFIDENTIAL AND PROPRIETARY TO SAMTEC INC. AND SHALL NOT BE REPRODUCED OR TRANSMITTED TO OTHER DOCUMENTS OR DISCLOSED TO OTHERS OR USED FOR ANY PURPOSE OTHER THAN THAT FOR WHICH IT WAS OBTAINED WITHOUT THE EXPRESSED WRITTEN CONSENT OF SAMTEC INC.

MATERIAL:
INSULATOR:
BLACK, LCP, UL 94 VO
CONTACT:
PHOSPHOR BRONZE

EXISPROD/ASSEMBLY050
MOLC-SMT

samtec

520 PARK EAST BLVD. NEW ALBANY, INDIANA 47150
PHONE (812) 944-6733 P.O. BOX 1147
CODE 55322

MADE BY: GREG REIDINGER 3-29-93
CHECKED BY: McCARTIN

ENG APPROVAL
DEM

MOLC-1XX-02-XXX-Q-XX-XX
SHEET 1 OF 1