

ITEM NO.	NAME	MATERIAL	NOTES
1	HOUSING	PA66	UL94-V0
2	SCREW	STEEL	M2.5/ZN PLATED
3	WIRE CONNECTOR	STEEL	M2.5/ZN PLATED
4	CONDUCTOR	COPPER ALLOY	TIN PLATED

PART NO.	COLOR	PANTONE #
DDNS10-GY	GREY	COOL GRAY2U

REVISIONS					
REV	ZONE	DESCRIPTION	DATE	ECN	BY
A	-	INITIAL RELEASE	09/24/2012	BU-J12374	TJN

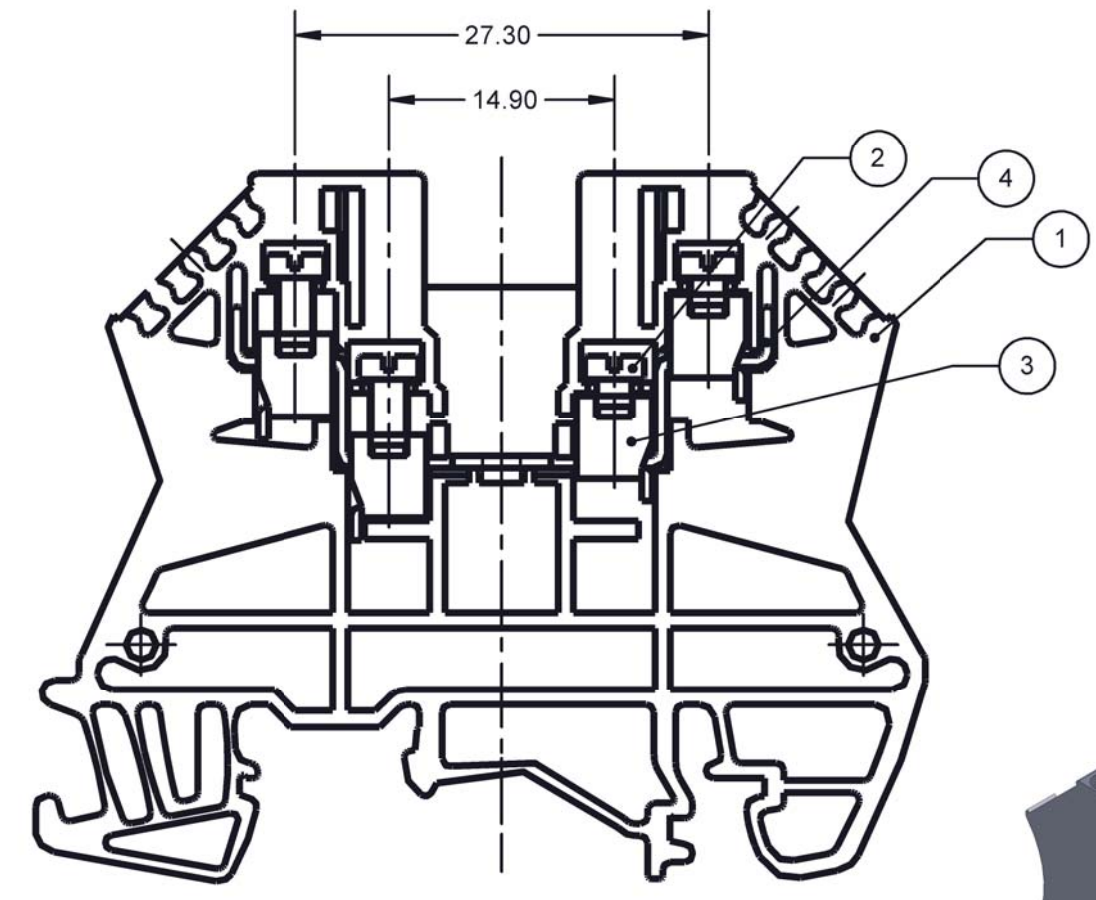
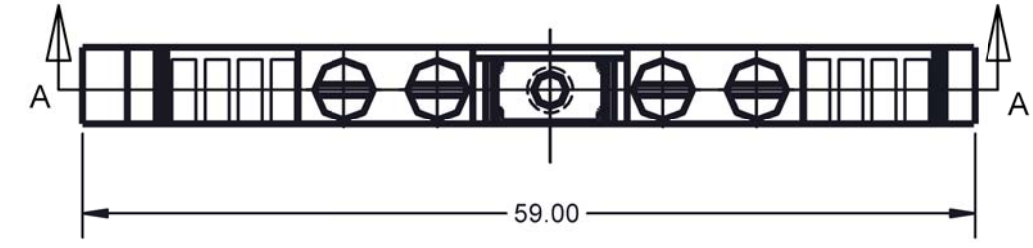
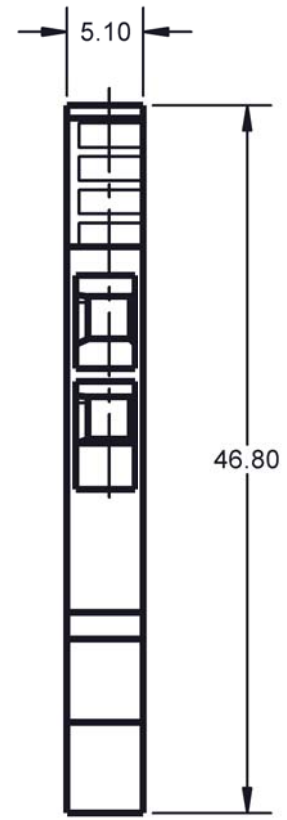
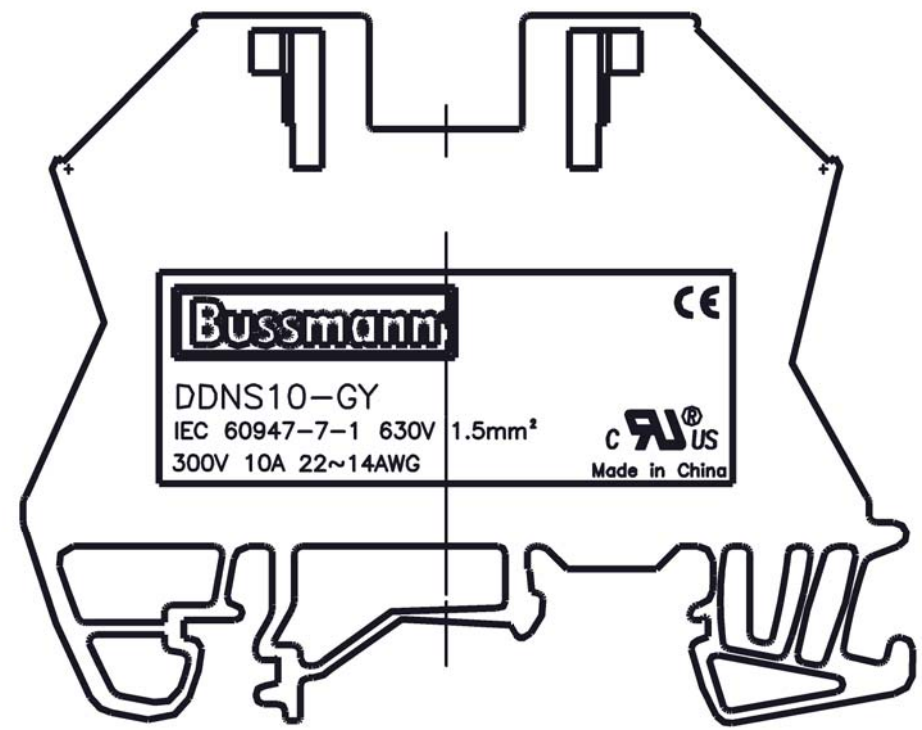

SECTION A-A

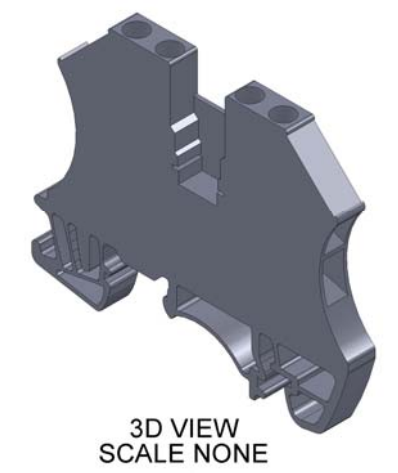

- NOTES:
- RATINGS: UL 300V/10A, IEC 630V/17.5A
INSULATION WITHSTAND VOLTAGE 2000VAC/1MINUTE
TEMPERATURE RANGE -40°C~105°C
 - SEE 2A2943 FOR DIN DIMENSION DETAILS
 - SCREW TORQUE 0.4N-M (3.5IN-LB)
 - WIRE RANGE UL 22~14AWG, IEC 0.5~1.5 mm²
 - ASSEMBLY MUST BE FREE OF OIL, GREASE AND OTHER FOREIGN MATERIALS.
 - ASSEMBLY MUST COMPLY WITH RoHS SPECIFICATION #1P2163.

MODEL SOURCE DATA --	MODEL VERSION --	GENERAL DRAWING PRACTICES IN ACCORDANCE WITH ASME - Y14.100-2004 DIMENSIONS AND TOLERANCES IN ACCORDANCE WITH ASME - Y14.5M-1994	APPROVALS DESIGNED: TJN DRAWN: TJN MANUFACTURING ENGINEER: -- MATERIAL: SEE TABLE FINISH: SEE TABLE	DATE 09/26/2012 09/26/2012 --/--/----	 St. Louis, MO 63178 (USA)
THIS DRAWING IS AN UNCONTROLLED COPY IF PRINTED OR SENT ELECTRONICALLY. DO NOT SCALE DRAWING.		UNLESS OTHERWISE SPECIFIED DIMENSIONS ARE IN MILLIMETERS TOLERANCES TO BE: ONE PLACE X.X = ±0.3 mm TWO PLACE X.X X = ±0.13 mm ALL ANGLES X X = ±1°	TITLE FEED THROUGH TERMINAL BLOCK		
CONFIDENTIAL. THE INFORMATION CONTAINED IN THIS DOCUMENT IS THE PROPERTY OF COOPER INDUSTRIES, INC. IT IS NOT FOR PUBLIC DISCLOSURE. POSSESSION OF THE INFORMATION DOES NOT CONVEY ANY RIGHT TO LOAN, SELL, OR DISCLOSE THE INFORMATION. UNAUTHORIZED REPRODUCTION OR USE OF THE INFORMATION IS PROHIBITED. THIS DOCUMENT IS TO BE RETURNED TO COOPER INDUSTRIES, INC. UPON COMPLETION OF THE PURPOSE FOR WHICH IT WAS LOANED OR UPON REQUEST.		SPECIAL CHARACTERISTIC $\diamond (0)$ SIGNIFICANT CHARACTERISTIC $\triangle (0)$	SIZE A3		DWG NO. DDNS10-XX
COPYRIGHT, COOPER INDUSTRIES, INC. THIS IS AN UNPUBLISHED WORK. THE DISCLOSURE OF THIS WORK IS LIMITED TO SELECT PERSONNEL. FURTHER DISSEMINATION OR DISCLOSURE TO THE PUBLIC IS PROHIBITED. THIS UNPUBLISHED WORK IS PROTECTED BY FEDERAL COPYRIGHT LAW AND ALL RIGHTS THEREUNDER ARE RESERVED BY COOPER INDUSTRIES, INC.		THIRD ANGLE PROJECTION	SCALE: 2:1		SHEET 1 OF 1