

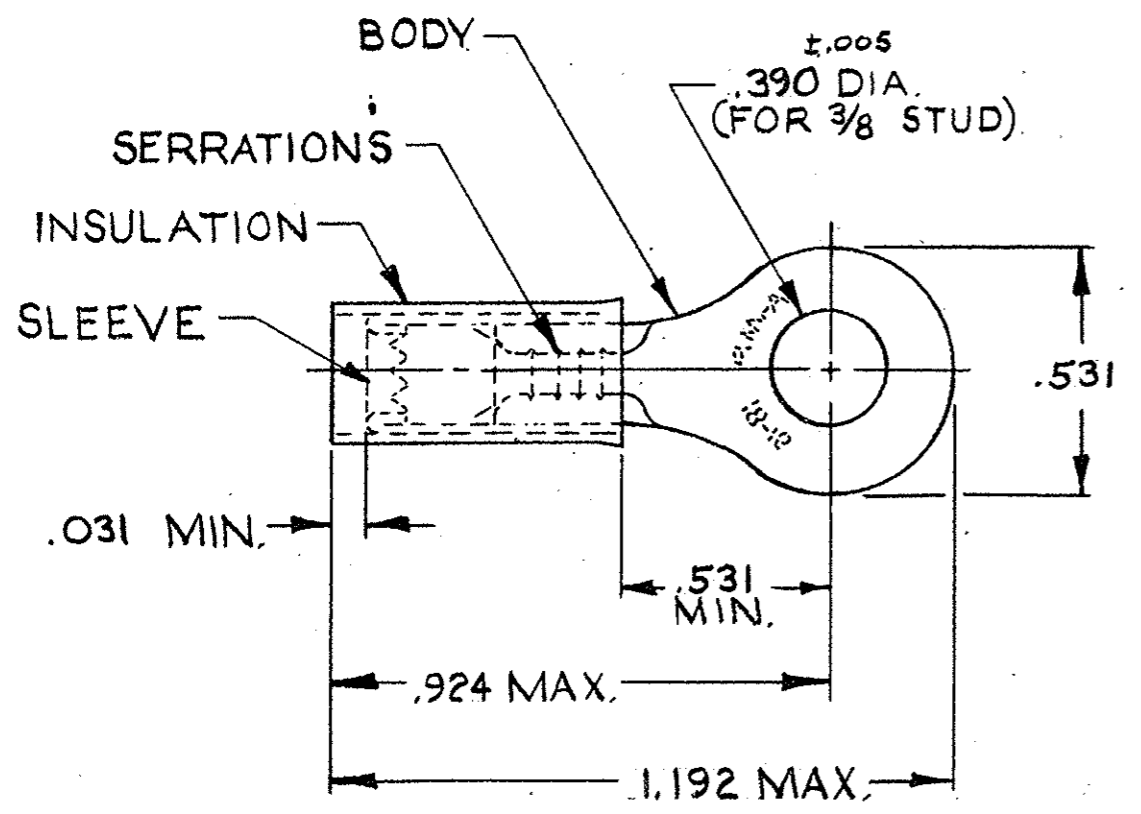

© 1967 BY AMP INCORPORATED. ALL RIGHTS RESERVED. AMP PRODUCTS COVERED BY PATENTS AND/OR PATENTS PENDING.

REVISIONS				
ZONE	LTR	DESCRIPTION	DATE	APPROVED
	B	REDRAWN & REV. P6077 SK	7-30-69	FCY
	C	REVISED PC-5579 LHM	10-8-70	JME
	D	REVISED PC-5578 TC	2-23-77	LJD
	E	REV/ 0410-0094-98	2-5-99	ME/MS
	E1	REV PER ECR 05-013140	10/20/05	DR/TM



FOR .055 TO .135 WIRE INSULATION DIA.
TONGUE MATERIAL THK = .031 ±.002

1	WIRE TERMINAL	50838	BODY: COPPER (ASTM B152) NICKEL PLATE (QQ-N-290) .0003 AVG. EXT. THK.		
			SLEEVE: COPPER (ASTM B152) NICKEL PL (QQ-N-290). 00003 AVG. EXT. THK.		
			INSULATION: TEFLON (ASTM D3295) COLOR: ORANGE		
QTY	DESCRIPTION	PART NO.	MATERIAL & FINISH		
UNLESS OTHERWISE SPECIFIED DIMENSIONS ARE IN INCHES TOLERANCES ON: DECIMALS ± .008 ANGLES ± 5°		CONTRACT NO. H	 AMP INCORPORATED HARRISBURG, PENNSYLVANIA		
MATERIAL		DR. <i>Steve Kantz</i> 7-24-69			
SEE TABLE		CHK. <i>R.C. Longfield</i> 7-30-69	NAME WIRE TERMINAL		
		APPD. <i>L. Swabel</i> 8-6-69	PIDG - STRATO-THERM - RING TONGUE		
		REL. <i>J.M. Evans</i> 8/6/69	WIRE SIZE: 18-16		
		DSGN APPD.	SIZE B	CODE IDENT NO. 00779	NUMBER 50838
		OTHER APPD.	SCALE NTS	SHEET 10F1	