

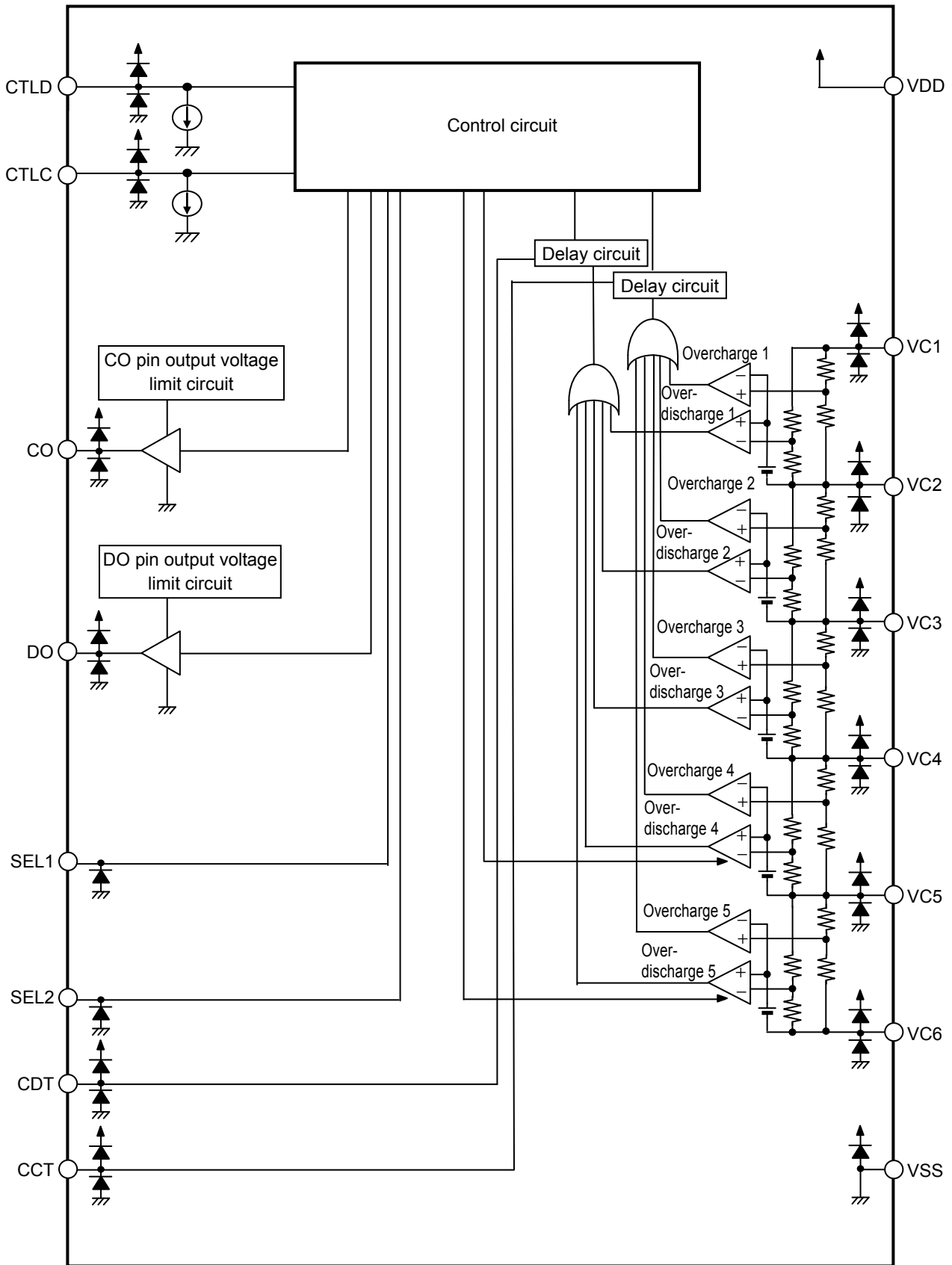

■ **Block Diagram**



**Remark** Diodes in the figure are parasitic diodes.

**Figure 1**

**■ Product Name Structure**

**1. Product name**

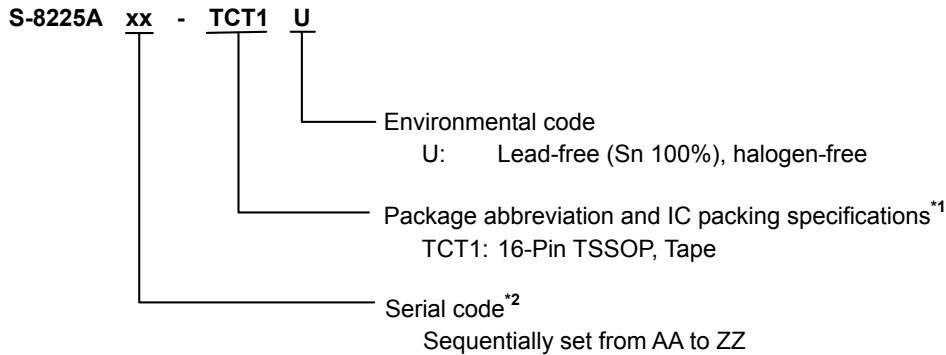

\*1. Refer to the tape drawing.

\*2. Refer to "3. Product name list".

**2. Package**

**Table 1 Package Drawing Codes**

Package Name	Dimension	Tape	Reel
16-Pin TSSOP	FT016-A-P-SD	FT016-A-C-SD	FT016-A-R-S1

**3. Product name list**

**Table 2**

Product Name	Overcharge Detection Voltage [V <sub>CU</sub> ]	Overcharge Release Voltage [V <sub>CL</sub> ]	Overdischarge Detection Voltage [V <sub>DL</sub> ]	Overdischarge Release Voltage [V <sub>DU</sub> ]	0 V Battery Detection Function
S-8225AAA-TCT1U	4.225 V	4.125 V	2.300 V	2.500 V	Available
S-8225AAB-TCT1U	4.400 V	4.300 V	2.300 V	2.500 V	Available
S-8225AAC-TCT1U	4.250 V	4.150 V	2.500 V	3.000 V	Unavailable
S-8225AAD-TCT1U	4.350 V	4.350 V	2.500 V	2.700 V	Unavailable
S-8225AAE-TCT1U	4.225 V	4.125 V	2.300 V	3.000 pV	Unavailable
S-8225AAF-TCT1U	4.215 V	4.155 V	2.800 V	3.000 V	Available
S-8225AAG-TCT1U	4.250 V	4.250 V	2.500 V	2.700 V	Unavailable
S-8225AAH-TCT1U	4.150 V	4.000 V	2.500V	3.000 V	Available
S-8225AAI-TCT1U	4.200 V	4.150 V	2.500V	2.550 V	Available

**Remark** Please contact our sales office for products with detection voltage values other than those specified above.

■ **Pin Configuration**

1. 16-Pin TSSOP

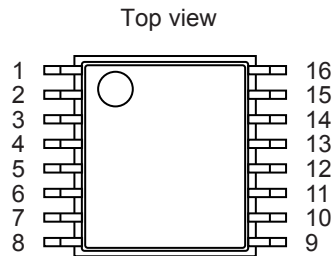

**Figure 2**

**Table 3**

Pin No.	Symbol	Description
1	CTLD	DO control pin
2	CTLC	CO control pin
3	CO	Output pin for overcharge detection
4	DO	Output pin for overdischarge detection
5	SEL1	Switching pins for 3-serial to 5-serial cell*1
6	SEL2	
7	CDT	Capacitor connection pin for delay for overdischarge detection voltage
8	CCT	Capacitor connection pin for delay for overcharge detection voltage
9	VSS	Input pin for negative power supply, connection pin for negative voltage of battery 5
10	VC6	Connection pin for negative voltage of battery 5
11	VC5	Connection pin for negative voltage of battery 4, connection pin for positive voltage of battery 5
12	VC4	Connection pin for negative voltage of battery 3, connection pin for positive voltage of battery 4
13	VC3	Connection pin for negative voltage of battery 2, connection pin for positive voltage of battery 3
14	VC2	Connection pin for negative voltage of battery 1, connection pin for positive voltage of battery 2
15	VC1	Connection pin for positive voltage of battery 1
16	VDD	Input pin for positive power supply, connection pin for positive voltage of battery 1

\*1. Refer to "7. SEL pin" in "■ Operation" for setting of the SEL1 pin and the SEL2 pin.

■ **Absolute Maximum Ratings**

**Table 4**

(Ta = +25°C unless otherwise specified)

Item	Symbol	Applied Pin	Absolute Maximum Rating	Unit
Input voltage between VDD pin and VSS pin	V <sub>DS</sub>	VDD	V <sub>SS</sub> – 0.3 to V <sub>SS</sub> + 28	V
Input pin voltage	V <sub>IN</sub>	VC1, VC2, VC3, VC4, VC5, VC6, SEL1, SEL2, CTLC, CTLD, CCT, CDT	V <sub>SS</sub> – 0.3 to V <sub>DD</sub> + 0.3	V
Output pin voltage	V <sub>OUT</sub>	DO, CO	V <sub>SS</sub> – 0.3 to V <sub>DD</sub> + 0.3	V
Power dissipation	P <sub>D</sub>	–	1100 <sup>*1</sup>	mW
Operation ambient temperature	T <sub>opr</sub>	–	–40 to +85	°C
Storage temperature	T <sub>stg</sub>	–	–40 to +125	°C

- \*1. When mounted on board  
 [Mounted board]  
 (1) Board size: 114.3 mm × 76.2 mm × t1.6 mm  
 (2) Board name: JEDEC STANDARD51-7

**Caution** The absolute maximum ratings are rated values exceeding which the product could suffer physical damage. These values must therefore not be exceeded under any conditions.

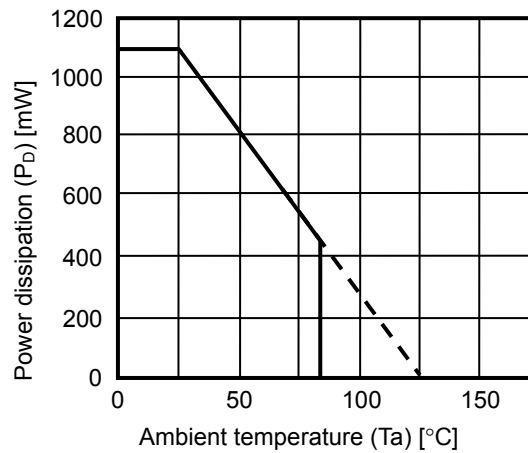

**Figure 3 Power Dissipation of Package (When Mounted on Board)**

■ **Electrical Characteristics**

**Table 5 (1 / 2)**

(Ta = +25°C, V<sub>DS</sub> = V<sub>DD</sub> - V<sub>SS</sub> = V1 + V2 + V3 + V4 + V5 unless otherwise specified)

Item	Symbol	Condition	Min.	Typ.	Max.	Unit	Test Circuit
<b>Detection Voltage</b>							
Overcharge detection voltage n (n = 1, 2, 3, 4, 5)	V <sub>CU<sub>n</sub></sub>	Ta = +25°C V1 = V2 = V3 = V4 = V5 = V <sub>CU</sub> - 0.05 V	V <sub>CU<sub>n</sub></sub> - 0.020	V <sub>CU<sub>n</sub></sub>	V <sub>CU<sub>n</sub></sub> + 0.020	V	1
		Ta = 0°C to +60°C*1 V1 = V2 = V3 = V4 = V5 = V <sub>CU</sub> - 0.05 V	V <sub>CU<sub>n</sub></sub> - 0.030	V <sub>CU<sub>n</sub></sub>	V <sub>CU<sub>n</sub></sub> + 0.030	V	1
Overcharge release voltage n (n = 1, 2, 3, 4, 5)	V <sub>CL<sub>n</sub></sub>	-	V <sub>CL<sub>n</sub></sub> - 0.050	V <sub>CL<sub>n</sub></sub>	V <sub>CL<sub>n</sub></sub> + 0.050	V	1
Overdischarge detection voltage n (n = 1, 2, 3, 4, 5)	V <sub>DL<sub>n</sub></sub>	-	V <sub>DL<sub>n</sub></sub> - 0.080	V <sub>DL<sub>n</sub></sub>	V <sub>DL<sub>n</sub></sub> + 0.080	V	1
Overdischarge release voltage n (n = 1, 2, 3, 4, 5)	V <sub>DU<sub>n</sub></sub>	-	V <sub>DU<sub>n</sub></sub> - 0.100	V <sub>DU<sub>n</sub></sub>	V <sub>DU<sub>n</sub></sub> + 0.100	V	1
0 V battery detection voltage n (n = 1, 2, 3, 4, 5)	V <sub>0INH<sub>n</sub></sub>	0 V battery detection function "available"	0.4	0.7	1.1	V	1
<b>Delay Time Function*2</b>							
Overcharge detection delay time	t <sub>CU</sub>	C <sub>CCT</sub> = 0.1 μF	0.67	1.00	1.33	s	2
Overdischarge detection delay time	t <sub>DL</sub>	C <sub>CDT</sub> = 0.1 μF	0.67	1.00	1.33	s	2
CCT pin voltage	V <sub>CCT</sub>	-	-	1.5	5.0	V	2
CDT pin voltage	V <sub>CDT</sub>	-	-	1.5	5.0	V	2
<b>Input Voltage</b>							
Operation voltage between VDD pin and VSS pin	V <sub>DSOP</sub>	Fixed output voltage of CO pin and DO pin	4	-	26	V	-
CTLC pin voltage "H"	V <sub>CTLCH</sub>	-	-	-	V <sub>DS</sub> - 0.8	V	3
CTLC pin voltage "L"	V <sub>CTLCL</sub>	-	V <sub>DS</sub> - 4.0	-	-	V	3
CTLD pin voltage "H"	V <sub>CTLDH</sub>	-	-	-	V <sub>DS</sub> - 0.8	V	3
CTLD pin voltage "L"	V <sub>CTLDL</sub>	-	V <sub>DS</sub> - 4.0	-	-	V	3
SEL1 pin voltage "H"	V <sub>SELH1</sub>	-	V <sub>DS</sub> × 0.8	-	-	V	3
SEL2 pin voltage "H"	V <sub>SELH2</sub>	-	V <sub>DS</sub> × 0.8	-	-	V	3
SEL1 pin voltage "L"	V <sub>SELL1</sub>	-	-	-	V <sub>DS</sub> × 0.2	V	3
SEL2 pin voltage "L"	V <sub>SELL2</sub>	-	-	-	V <sub>DS</sub> × 0.2	V	3
<b>Output Voltage</b>							
CO pin voltage "H"	V <sub>COH</sub>	-	5.0	8.0	12.0	V	4
DO pin voltage "H"	V <sub>DOH</sub>	-	5.0	8.0	12.0	V	4
<b>Input Current</b>							
Current consumption during operation	I <sub>OPE</sub>	V1 = V2 = V3 = V4 = V5 = 3.4 V	-	13	22	μA	5
Current consumption during power-down	I <sub>PDN</sub>	V1 = V2 = V3 = V4 = V5 = 1.6 V	-	2.6	4.5	μA	5
VC1 pin current	I <sub>VC1</sub>	V1 = V2 = V3 = V4 = V5 = 3.4 V, V6 = V7 = V <sub>DS</sub> , V8 = V9 = 0 V	-	0.4	0.8	μA	6
VC2 to VC5 pins current	I <sub>VC2 to VC5</sub>	V1 = V2 = V3 = V4 = V5 = 3.4 V, V6 = V7 = V <sub>DS</sub> , V8 = V9 = 0 V	-1.0	-	1.0	μA	6
VC6 pin current	I <sub>VC6</sub>	V1 = V2 = V3 = V4 = V5 = 3.4 V, V6 = V7 = V <sub>DS</sub> , V8 = V9 = 0 V	-3.0	-1.0	-	μA	6
CTLC pin current "H"	I <sub>CTLCH</sub>	V1 = V2 = V3 = V4 = V5 = 3.4 V, V6 = V7 = V <sub>DS</sub> , V8 = V9 = 0 V	0.4	0.6	0.8	μA	6
CTLD pin current "H"	I <sub>CTLDH</sub>	V1 = V2 = V3 = V4 = V5 = 3.4 V, V6 = V7 = V <sub>DS</sub> , V8 = V9 = 0 V	0.4	0.6	0.8	μA	6

**BATTERY MONITORING IC FOR 3-SERIAL TO 5-SERIAL CELL PACK**  
**S-8225A Series**

Rev.1.8\_00

**Table 5 (2 / 2)**

(Ta = +25°C, V<sub>DS</sub> = V<sub>DD</sub> - V<sub>SS</sub> = V1 + V2 + V3 + V4 + V5 unless otherwise specified)

Item	Symbol	Condition	Min.	Typ.	Max.	Unit	Test Circuit
SEL1 pin current "H"	I <sub>SELH1</sub>	V1 = V2 = V3 = V4 = V5 = 3.4 V, V6 = V7 = V8 = V <sub>DS</sub> , V9 = 0 V	–	–	0.1	μA	6
SEL2 pin current "H"	I <sub>SELH2</sub>	V1 = V2 = V3 = V4 = V5 = 3.4 V, V6 = V7 = V9 = V <sub>DS</sub> , V8 = 0 V	–	–	0.1	μA	6
SEL1 pin current "L"	I <sub>SELL1</sub>	V1 = V2 = V3 = V4 = V5 = 3.4 V, V6 = V7 = V <sub>DS</sub> , V8 = V9 = 0 V	–0.1	–	–	μA	6
SEL1 pin current "L"	I <sub>SELL2</sub>	V1 = V2 = V3 = V4 = V5 = 3.4 V, V6 = V7 = V <sub>DS</sub> , V8 = V9 = 0 V	–0.1	–	–	μA	6
<b>Output Current</b>							
CO pin source current	I <sub>COH</sub>	–	–	–	–10	μA	7
CO pin sink current	I <sub>COL</sub>	–	10	–	–	μA	7
DO pin source current	I <sub>DOH</sub>	–	–	–	–10	μA	7
DO pin sink current	I <sub>DOL</sub>	–	10	–	–	μA	7

- \*1. Since products are not screened at high and low temperature, the specification for this temperature range is guaranteed by design, not tested in production.
- \*2. Refer to "6. Delay time setting" in "■ Operation" for details of the delay time function.

## ■ Test Circuits

1. **Overcharge detection voltage ( $V_{CU(n)}$ ), overcharge release voltage ( $V_{CL(n)}$ ), overdischarge detection voltage ( $V_{DL(n)}$ ), overdischarge release voltage ( $V_{DU(n)}$ )  
(Test circuit 1)**

$V_{CU1}$  is defined as the voltage V1 when V1 is gradually increased and the CO pin output becomes detection status after setting  $V1 = V2 = V3 = V4 = V5 = V_{CU} - 0.05$  V. After that,  $V_{CL1}$  is defined as the voltage V1 when V1 is gradually decreased and the CO pin output becomes release status after setting  $V2 = V3 = V4 = V5 = 3.2$  V. Moreover,  $V_{DL1}$  is defined as the voltage V1 when V1 is gradually decreased and the DO pin output becomes detection status after setting  $V1 = V2 = V3 = V4 = V5 = 3.5$  V. After that,  $V_{DU1}$  is defined as the voltage V1 when V1 is gradually increased and the DO pin output becomes release status.

Similarly,  $V_{CU(n)}$ ,  $V_{CL(n)}$ ,  $V_{DL(n)}$  and  $V_{DU(n)}$  can be defined by changing Vn (n = 2 to 5).

2. **0 V battery detection voltage ( $V_{0INH(n)}$ ) (0 V battery detection function "available")  
(Test circuit 1)**

$V_{0INH1}$  is defined as the voltage V1 when V1 is gradually decreased and the CO pin output becomes detection status after setting  $V1 = V2 = V3 = V4 = V5 = 3.4$  V.

Similarly,  $V_{0INH(n)}$  can be defined by changing Vn (n = 2 to 5).

3. **Overcharge detection delay time ( $t_{CU}$ ), overdischarge detection delay time ( $t_{DL}$ )  
(Test circuit 2)**

$t_{CU}$  is defined as the time period from when V1 changes from 3.4 V to 4.5 V to when the CO pin output becomes detection status after setting  $V1 = V2 = V3 = V4 = V5 = 3.4$  V.

Moreover,  $t_{DL}$  is defined as the time period from when V1 changes from 3.4 V to 1.6 V to when the DO pin output becomes detection status after setting  $V1 = V2 = V3 = V4 = V5 = 3.4$  V.

4. **CCT pin voltage ( $V_{CCT}$ ), CDT pin voltage ( $V_{CDT}$ )  
(Test circuit 2)**

$V_{CCT}$  is defined as the voltage between the CCT pin and the VSS pin during the time period when V1 changes from 3.4 V to 4.5 V to when the CO pin output becomes detection status after setting  $V1 = V2 = V3 = V4 = V5 = 3.4$  V.

Moreover,  $V_{CDT}$  is defined as the voltage between the CDT pin and the VSS pin during the time period when V1 changes from 3.4 V to 1.6 V to when the DO pin output becomes detection status after setting  $V1 = V2 = V3 = V4 = V5 = 3.4$  V.

5. **CTLC pin voltage "H" ( $V_{CTLCH}$ ), CTLC pin voltage "L" ( $V_{CTLCL}$ ), CTLD pin voltage "H" ( $V_{CTLDH}$ ), CTLD pin voltage "L" ( $V_{CTLDL}$ )  
(Test circuit 3)**

$V_{CTLCL}$  is defined as the voltage V6 when V6 is gradually decreased and the CO pin output becomes detection status after setting  $V1 = V2 = V3 = V4 = V5 = 3.4$  V,  $V6 = V7 = V_{DS} (= V1 + V2 + V3 + V4 + V5)$ ,  $V8 = V9 = 0$  V. After that,  $V_{CTLCH}$  is defined as the voltage V6 when V6 is gradually increased and the CO pin output becomes release status. Moreover,  $V_{CTLDL}$  is defined as the voltage V7 when V7 is gradually decreased and the DO pin output becomes detection status after setting  $V1 = V2 = V3 = V4 = V5 = 3.4$  V,  $V6 = V7 = V_{DS} (= V1 + V2 + V3 + V4 + V5)$ ,  $V8 = V9 = 0$  V. After that,  $V_{CTLDH}$  is defined as the voltage V7 when V7 is gradually increased and the DO pin output becomes release status.



**6. SEL1 pin voltage "H" ( $V_{SELH1}$ ), SEL2 pin voltage "H" ( $V_{SELH2}$ ), SEL1 pin voltage "L" ( $V_{SELL1}$ ), SEL2 pin voltage "L" ( $V_{SELL2}$ )  
(Test circuit 3)**

$V_{SELH1}$  is defined as the voltage V8 when V8 is gradually increased and the DO pin output becomes release status after setting  $V1 = V2 = V3 = V5 = 3.5\text{ V}$ ,  $V4 = 0\text{ V}$ ,  $V6 = V7 = V_{DS} (= V1 + V2 + V3 + V4 + V5)$ ,  $V8 = V9 = 0\text{ V}$ . After that,  $V_{SELL1}$  is defined as the voltage V8 when V8 is gradually decreased and the DO pin output becomes detection status.

Moreover,  $V_{SELH2}$  is defined as the voltage V9 when V9 is gradually increased and the DO pin output becomes release status after setting  $V1 = V2 = V3 = V4 = 3.5\text{ V}$ ,  $V5 = 0\text{ V}$ ,  $V6 = V7 = V_{DS} (= V1 + V2 + V3 + V4 + V5)$ ,  $V8 = V9 = 0\text{ V}$ . After that,  $V_{SELL2}$  is defined as the voltage V9 when V9 is gradually decreased and the DO pin output becomes detection status.

**7. CO pin voltage "H" ( $V_{COH}$ ), DO pin voltage "H" ( $V_{DOH}$ )  
(Test circuit 4)**

$V_{COH}$  is defined as the voltage between the CO pin and the VSS pin when  $V1 = V2 = V3 = V4 = V5 = 3.4\text{ V}$ .

$V_{DOH}$  is defined as the voltage between the DO pin and the VSS pin when  $V1 = V2 = V3 = V4 = V5 = 3.4\text{ V}$ .

**8. CO pin source current ( $I_{COH}$ ), CO pin sink current ( $I_{COL}$ ), DO pin source current ( $I_{DOH}$ ), DO pin sink current ( $I_{DOL}$ )  
(Test circuit 7)**

$I_{COH}$  is defined as the CO pin current when  $V1 = V2 = V3 = V4 = V5 = 3.4\text{ V}$ ,  $V6 = V_{COH} - 0.5\text{ V}$ .

$I_{COL}$  is defined as the CO pin current when  $V1 = 6.8\text{ V}$ ,  $V2 = 0\text{ V}$ ,  $V3 = V4 = V5 = 3.4\text{ V}$ ,  $V6 = 0.5\text{ V}$ .

$I_{DOH}$  is defined as the DO pin current when  $V1 = V2 = V3 = V4 = V5 = 3.4\text{ V}$ ,  $V7 = V_{DOH} - 0.5\text{ V}$ .

$I_{DOL}$  is defined as the DO pin current when  $V1 = 6.8\text{ V}$ ,  $V2 = 0\text{ V}$ ,  $V3 = V4 = V5 = 3.4\text{ V}$ ,  $V7 = 0.5\text{ V}$ .

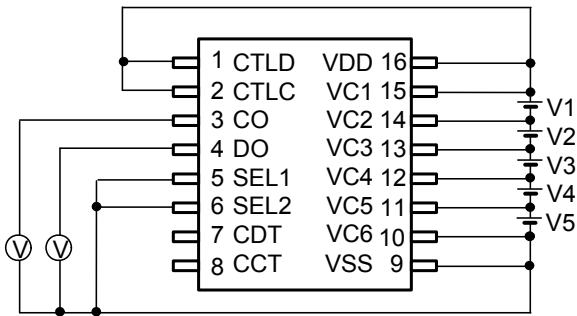

**Figure 4 Test Circuit 1**

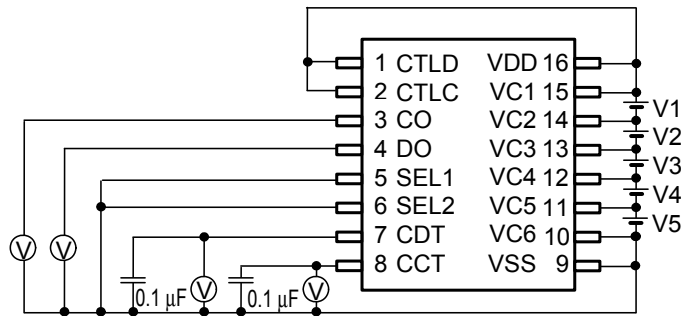

**Figure 5 Test Circuit 2**

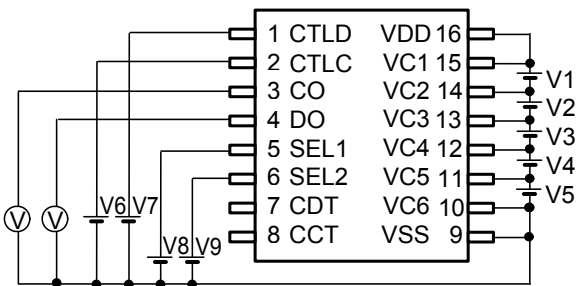

**Figure 6 Test Circuit 3**

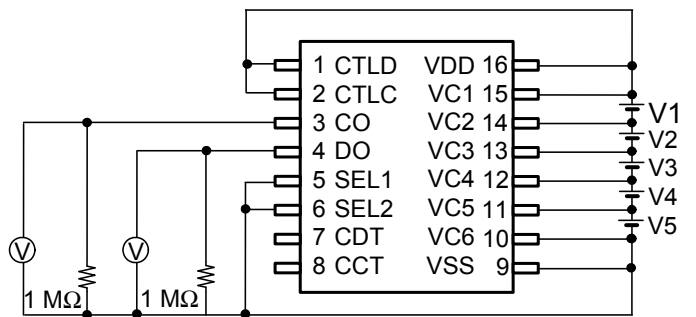

**Figure 7 Test Circuit 4**

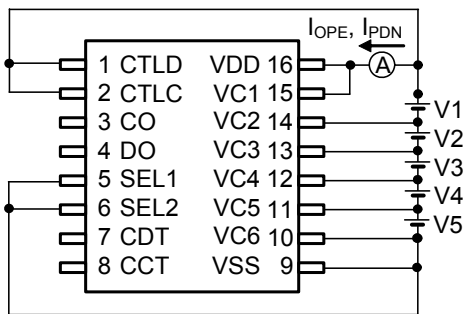

**Figure 8 Test Circuit 5**

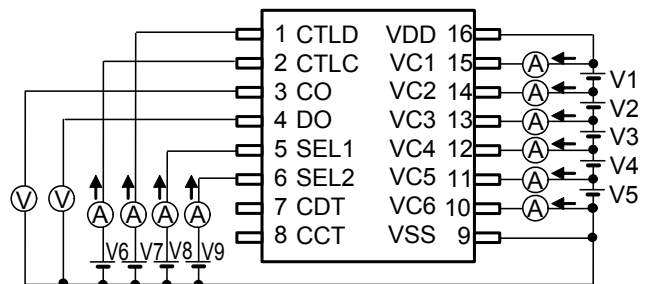

**Figure 9 Test Circuit 6**

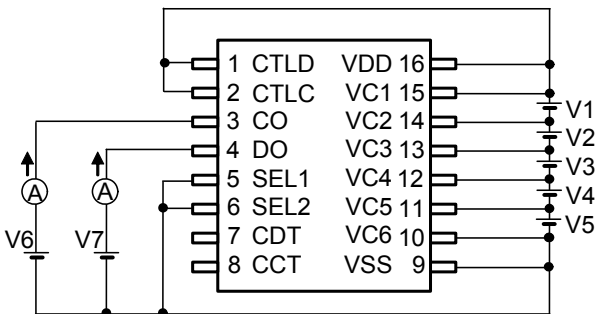

**Figure 10 Test Circuit 7**

## ■ Operation

**Remark** Refer to "■ Connection Examples of Battery Monitoring IC".

### 1. Normal status

When the voltage of each of the batteries is in the range from overcharge detection voltage ( $V_{CU_n}$ ) to overdischarge detection voltage ( $V_{DL_n}$ ), and the CTLC pin input voltage ( $V_{CTLC}$ ) and the CTLD pin input voltage ( $V_{CTLD}$ ) are higher than the CTLC pin voltage "H" ( $V_{CTLCH}$ ) and the CTLD pin voltage "H" ( $V_{CTLDH}$ ), respectively, the S-8225A Series defines each of the CO pin output voltage ( $V_{CO}$ ) and the DO pin output voltage ( $V_{DO}$ ) as "H". This is called normal status.

$V_{CO}$  is defined as the CO pin voltage "H" ( $V_{COH}$ ) when it is "H". Similarly,  $V_{DO}$  is defined as the DO pin voltage "H" ( $V_{DOH}$ ) when it is "H".

**Caution** When the battery is connected for the first time, the S-8225A Series becomes normal status if the voltage of each of the batteries is in the range from overcharge release voltage ( $V_{CL_n}$ ) to overdischarge release voltage ( $V_{DU_n}$ ).

### 2. Overcharge status

When the voltage of one of the batteries becomes  $V_{CU_n}$  or higher, the CO pin output inverts and the S-8225A Series becomes detection status. This is called overcharge status.

When the voltage of each of the batteries becomes overcharge release voltage ( $V_{CL_n}$ ) or lower, the overcharge status is released and the S-8225A Series returns to normal status.

### 3. Overdischarge status

When the voltage of one of the batteries becomes  $V_{DL_n}$  or lower, the DO pin output inverts and the S-8225A Series becomes detection status. This is called overdischarge status.

When the voltage of each of the batteries becomes overdischarge release voltage ( $V_{DU_n}$ ) or higher, the overdischarge status is released and the S-8225A Series returns to normal status.

#### 4. CTLC pin and CTLD pin

The S-8225A Series has two pins to control.

The CTLC pin controls the output voltage from the CO pin; the CTLD pin controls the output voltage from the DO pin. Thus it is possible for users to control the output voltages from the CO pin and DO pin, respectively. These controls precede the battery protection circuit.

**Table 6 Status Set by CTLC Pin**

CTLC Pin	CO Pin
"H" <sup>*1</sup>	Normal status <sup>*4</sup>
Open <sup>*2</sup>	V <sub>SS</sub>
"L" <sup>*3</sup>	V <sub>SS</sub>

\*1. "H": CTLC  $\geq$  V<sub>CTLCH</sub>

\*2. Pulled down by I<sub>CTLCH</sub>

\*3. "L": CTLC  $\leq$  V<sub>CTLCL</sub>

\*4. The status is controlled by the voltage detection circuit.

**Table 7 Status Set by CTLD Pin**

CTLD Pin	DO Pin
"H" <sup>*1</sup>	Normal status <sup>*4</sup>
Open <sup>*2</sup>	V <sub>SS</sub>
"L" <sup>*3</sup>	V <sub>SS</sub>

\*1. "H": CTLD  $\geq$  V<sub>CTLDH</sub>

\*2. Pulled down by I<sub>CTLDH</sub>

\*3. "L": CTLD  $\leq$  V<sub>CTLDL</sub>

\*4. The status is controlled by the voltage detection circuit.

**Caution** When the power supply fluctuates, unexpected behavior might occur if an electrical potential is generated between the potentials of "H" level input to the CTLC / CTLD pins and IC's V<sub>DD</sub> by external filters.

#### 5. 0 V battery detection function

In the S-8225A Series, users are able to select a 0 V battery detection "available" function.

If this optional function is selected, the CO pin becomes detection status when the voltage of one of the batteries becomes 0 V battery detection voltage (V<sub>0INHR</sub>) or lower.

## 6. Delay time setting

When the voltage of one of the batteries becomes  $V_{CUH}$  or higher, the S-8225A Series charges the capacitor connected to the CCT pin rapidly up to the CCT pin voltage ( $V_{CCT}$ ). After that, The S-8225A Series discharges the capacitor with the constant current of 100 nA, and the CO pin output is defined as detection status at the time when the CCT pin voltage falls to a certain level or lower. The overcharge detection delay time ( $t_{CU}$ ) changes depending on the capacitor connected to the CCT pin.

$t_{CU}$  is calculated by the following formula.

Min. Typ. Max.

$$t_{CU} [s] = (6.7, 10, 13.3) \times C_{CCT} [\mu F]$$

Similarly, the overdischarge detection delay time ( $t_{DL}$ ) changes depending on the capacitor connected to the CDT pin.  $t_{DL}$  is calculated by the following formula.

Min. Typ. Max.

$$t_{DL} [s] = (6.7, 10, 13.3) \times C_{CDT} [\mu F]$$

Since the S-8225A Series charges the capacitor for delay rapidly, the voltage of the CCT pin and the CDT pin becomes large if the capacitance value is small. As a result, a variation between the calculated value of the delay time and the actual delay time is generated.

If the capacitance value is so large that the rapid charging can not be finished within the internal delay time, the output pin becomes detection status simultaneously with the end of internal delay time.

In addition, the charging current to the capacitor for delay passes through the VDD pin. Therefore, a large resistor connected to the VDD pin results in a big drop of the power supply voltage at the time of rapid charging which causes malfunction.

Regarding the recommended values for external components, refer to "**Table 9 Constants for External Components**".

## 7. SEL pin

In the S-8225A Series, switchable monitoring control between 3-cell to 5-cell is possible by using the SEL1 pin and the SEL2 pin. For example, since the overdischarge detection of V4 or V5 is prohibited and the overdischarge is not detected even if V4 or V5 is shorted when the SEL1 pin is "H" and the SEL2 pin is "L", the S-8225A Series can be used for 3-cell monitoring.

Be sure to use the SEL1 pin and the SEL2 pin at "H" or "L" potential.

**Table 8 Settings of SEL1 Pin and SEL2 Pin**

SEL1 pin	SEL2 pin	Setting
"H" <sup>*1</sup>	"H" <sup>*1</sup>	Prohibition
"H" <sup>*1</sup>	"L" <sup>*2</sup>	3-cell monitoring
"L" <sup>*2</sup>	"H" <sup>*1</sup>	4-cell monitoring
"L" <sup>*2</sup>	"L" <sup>*2</sup>	5-cell monitoring

\*1. "H":  $SEL1 \geq V_{SELH1}$  and  $SEL2 \geq V_{SELH2}$

\*2. "L":  $SEL1 \leq V_{SELL1}$  and  $SEL2 \leq V_{SELL2}$

■ **Timing Charts**

**1. Overcharge detection and overdischarge detection**

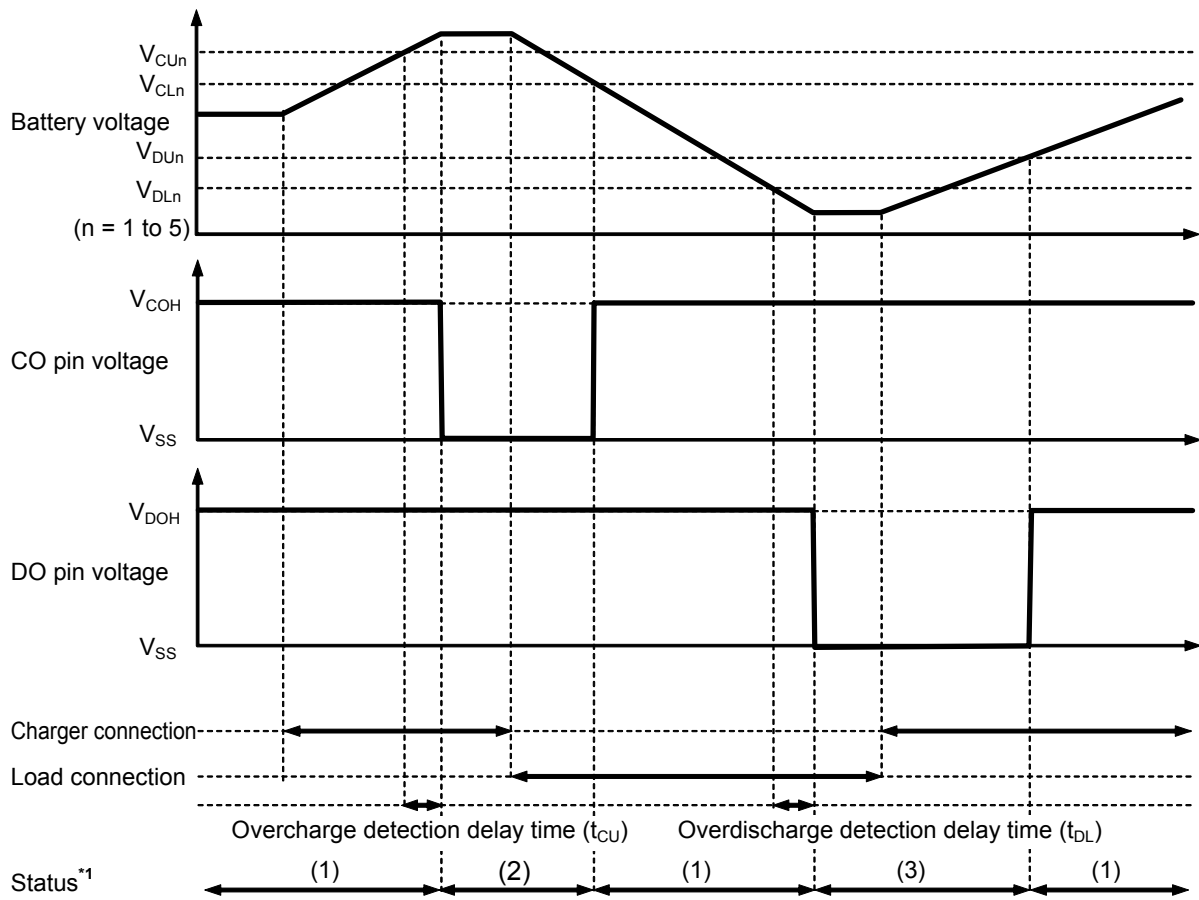

- \*1. (1): Normal status
- (2): Overcharge status
- (3): Overdischarge status

**Figure 11**

**2. Overcharge detection delay**

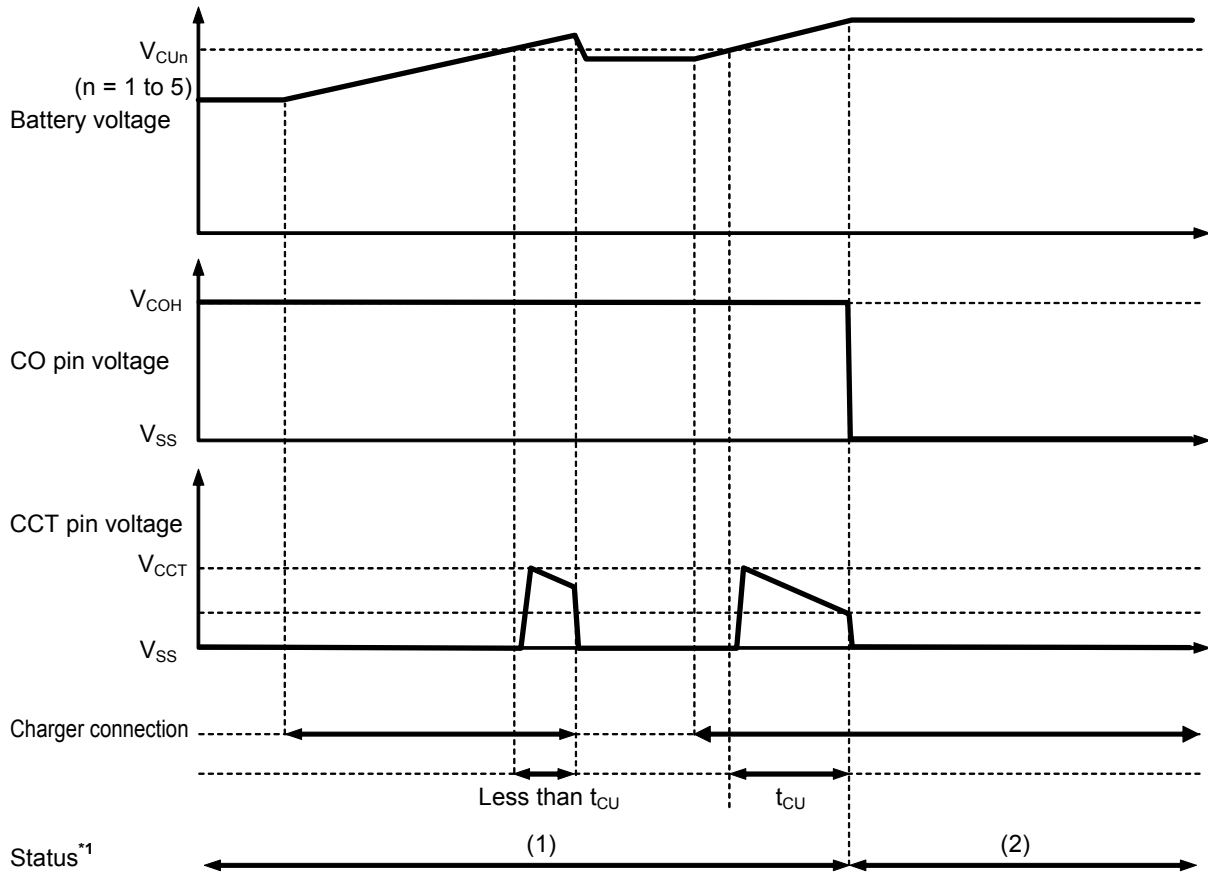

\*1. (1): Normal status  
 (2): Overcharge status

**Figure 12**

**3. Overdischarge detection delay**

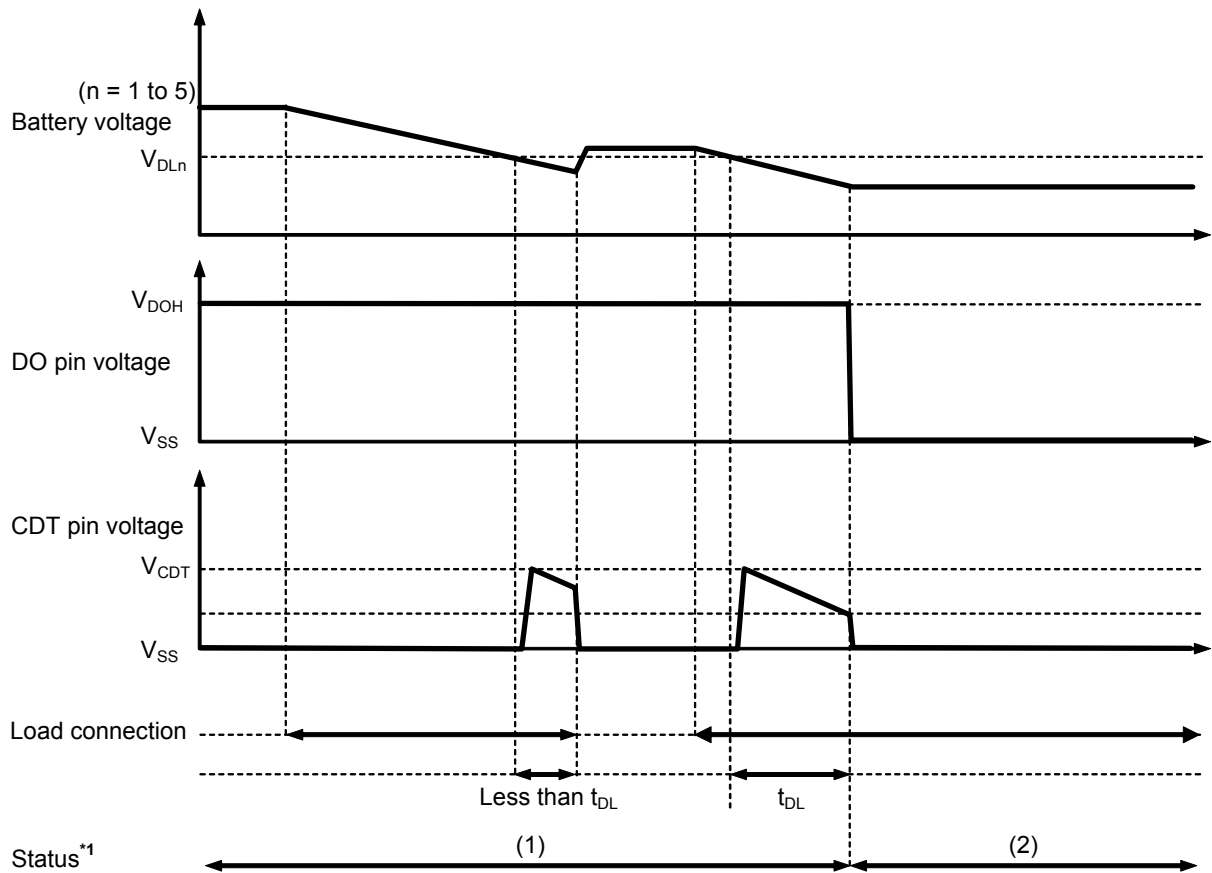

\*1. (1): Normal status  
 (2): Overdischarge status

**Figure 13**



■ **Connection Examples of Battery Monitoring IC**

1. **10-serial cell**

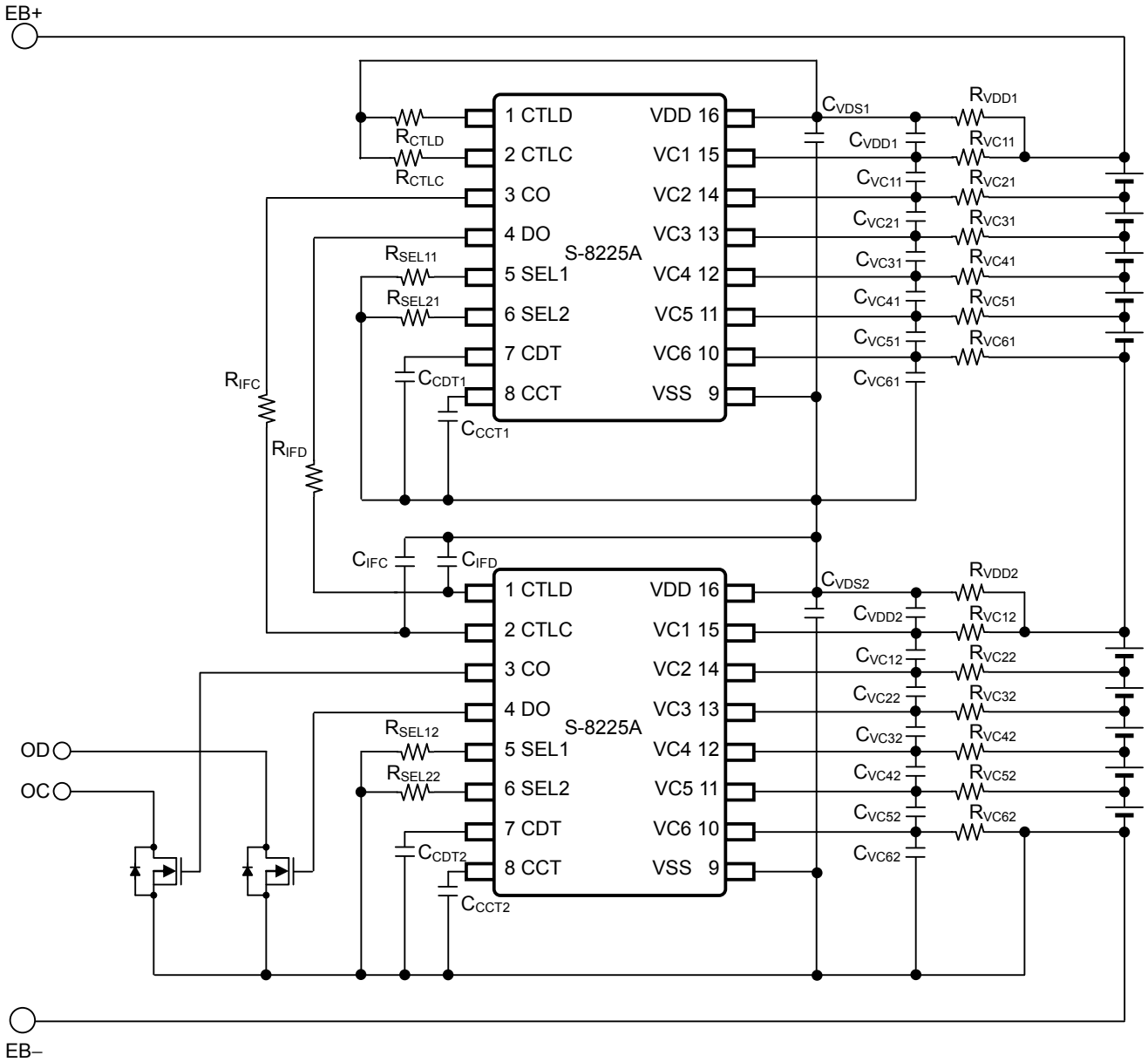

**Remark** Regarding the recommended values for external components, refer to "Table 9 Constants for External Components".

**Figure 14**

**2. 9-serial cell**

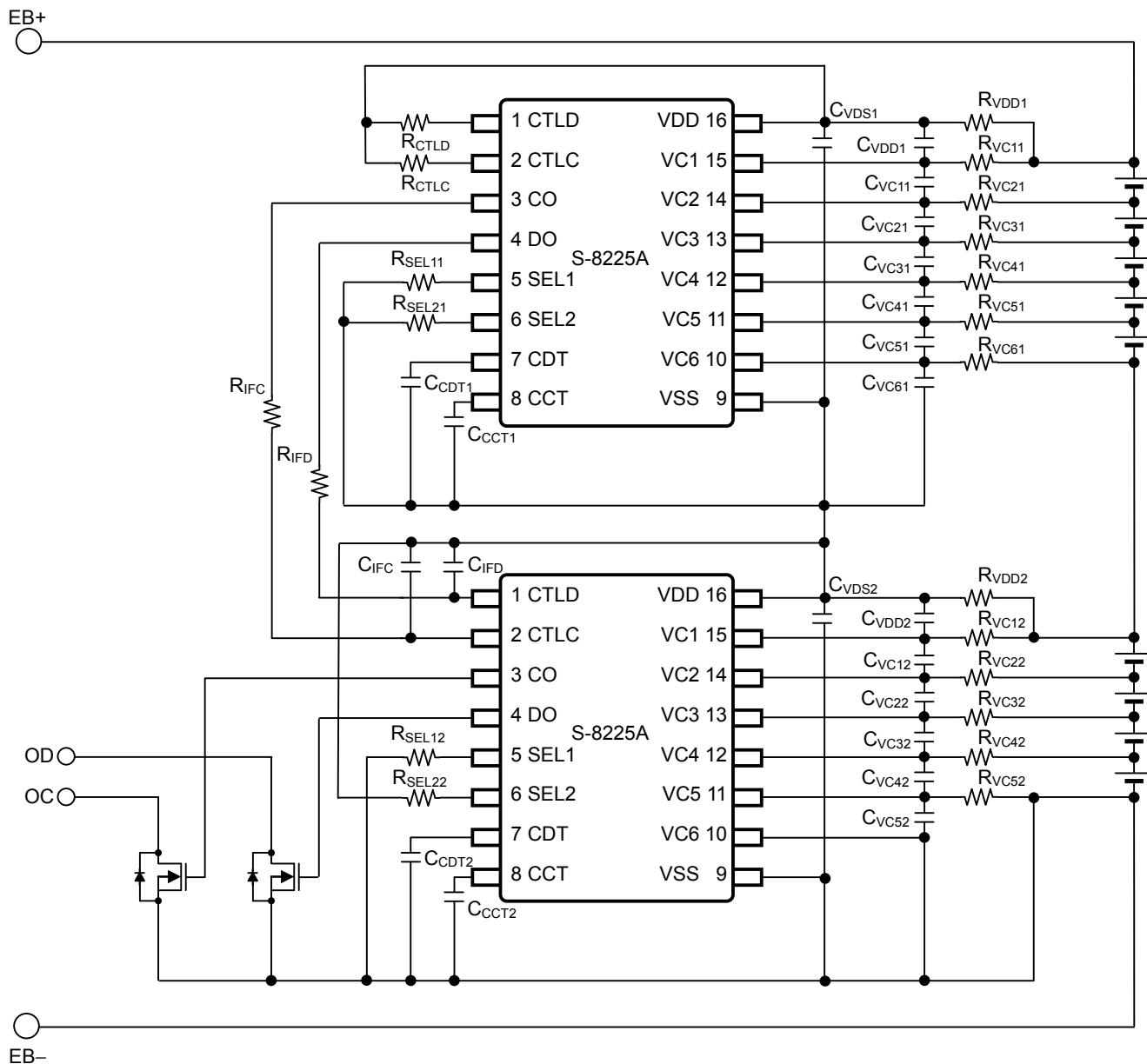

**Remark** Regarding the recommended values for external components, refer to "Table 9 Constants for External Components".

**Figure 15**

**BATTERY MONITORING IC FOR 3-SERIAL TO 5-SERIAL CELL PACK**  
**S-8225A Series**

Rev.1.8\_00

**3. 7-serial cell**

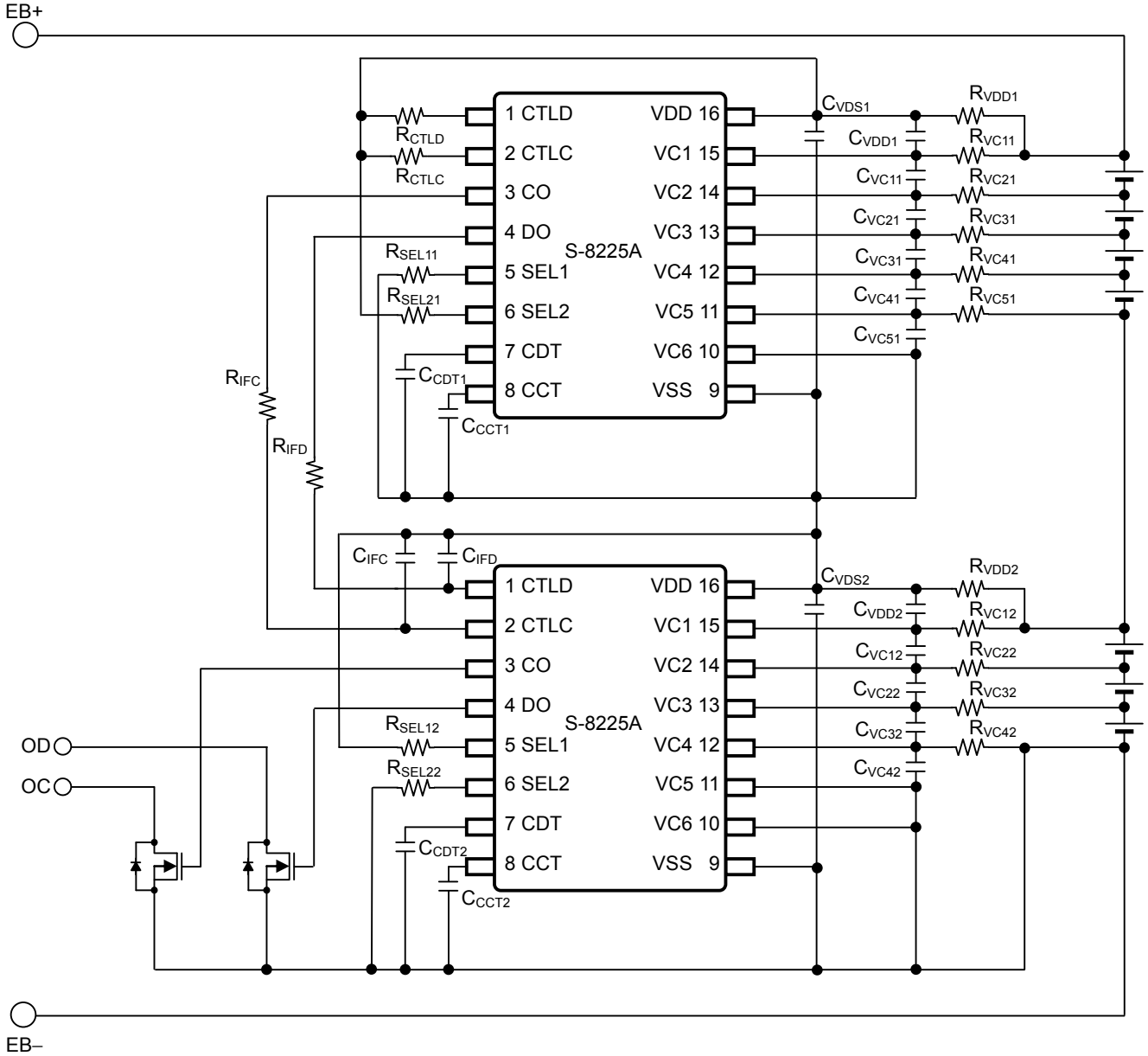

**Remark** Regarding the recommended values for external components, refer to "Table 9 Constants for External Components".

**Figure 16**

**Table 9 Constants for External Components**

Symbol	Min.	Typ.	Max.	Unit
R <sub>VDD1</sub> , R <sub>VDD2</sub>	50	100	1000	Ω
R <sub>VCn1</sub> , R <sub>VCn2</sub>	0.5	1	2	kΩ
C <sub>VDS1</sub> , C <sub>VDS2</sub>	0.01	0.1	1	μF
C <sub>VDD1</sub> , C <sub>VDD2</sub>	–	0	1	μF
C <sub>VCn1</sub> , C <sub>VCn2</sub>	0.01	0.1	1	μF
C <sub>CCT1</sub> , C <sub>CCT2</sub>	0.001	0.1	0.22	μF
C <sub>CDT1</sub> , C <sub>CDT2</sub>	0.001	0.1	0.22	μF
R <sub>IFC</sub> , R <sub>IFD</sub>	–	5.1	–	MΩ
C <sub>IFC</sub> , C <sub>IFD</sub>	–	1000	–	pF
R <sub>CTL1</sub> , R <sub>CTL2</sub>	–	1	–	kΩ
R <sub>SEL11</sub> , R <sub>SEL21</sub>	0.5	1	–	kΩ
R <sub>SEL12</sub> , R <sub>SEL22</sub>	0.5	1	–	kΩ

- Caution**
1. The above constants may be changed without notice.
  2. The example of connection shown above and the constant do not guarantee proper operation. Perform thorough evaluation using the actual application to set the constant.
  3. R<sub>VC1</sub> to R<sub>VC6</sub> and C<sub>VC1</sub> to C<sub>VC6</sub> should be the same constant, respectively.
  4. Set up R<sub>VCn</sub> and C<sub>VCn</sub> as  $R_{VCn} \times C_{VCn} \geq 50 \times 10^{-6}$ .
  5. Set up R<sub>VDD</sub> and C<sub>VDS</sub> as  $5 \times 10^{-6} \leq R_{VDD} \times C_{VDS} \leq 100 \times 10^{-6}$ .
  6. Set  $(R_{VDD} \times C_{VDS}) / (R_{VCn} \times C_{VCn}) = 0.1$ .

**Remark** n = 1 to 6

## ■ Precautions

- The application conditions for the input voltage, output voltage, and load current should not exceed the package power dissipation.
- If both an overcharge battery and an overdischarge battery are included among the whole batteries, the condition is set in overcharge status and overdischarge status. Therefore either charging or discharging is impossible.
- Do not apply an electrostatic discharge to this IC that exceeds the performance ratings of the built-in electrostatic protection circuit.
- SII Semiconductor Corporation claims no responsibility for any disputes arising out of or in connection with any infringement by products including this IC of patents owned by a third party.

■ **Characteristics (Typical Data)**

**1. Detection voltage**

**1. 1  $V_{CU}$  vs.  $T_a$**

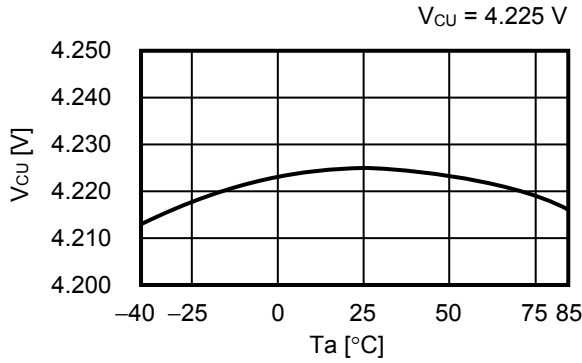

**1. 2  $V_{CL}$  vs.  $T_a$**

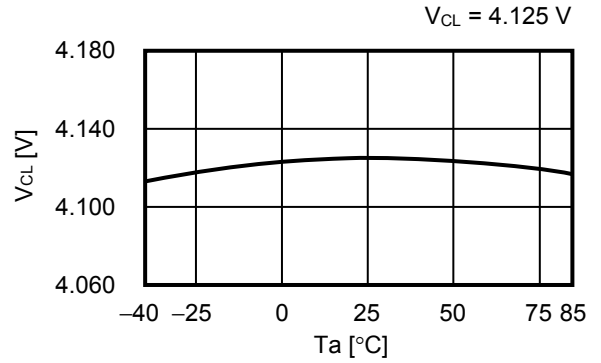

**1. 3  $V_{DL}$  vs.  $T_a$**

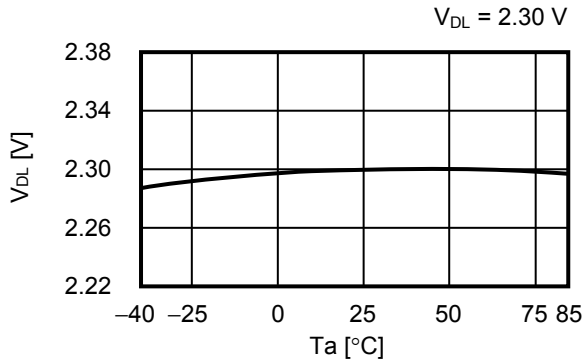

**1. 4  $V_{DU}$  vs.  $T_a$**

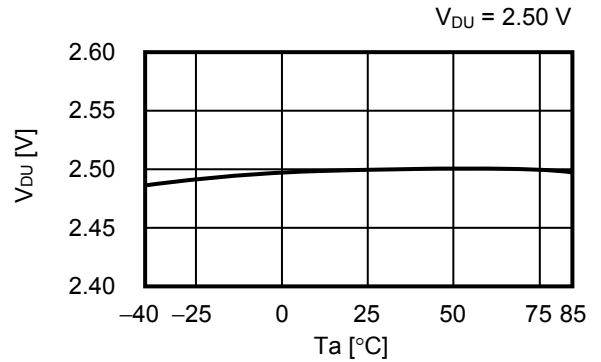

**2. Current consumption**

**2. 1  $I_{OPE}$  vs.  $T_a$**

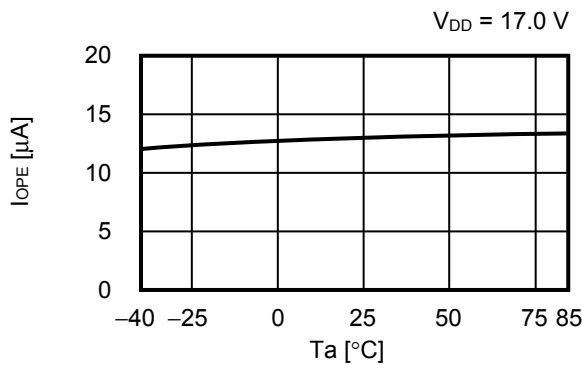

**2. 2  $I_{PDN}$  vs.  $T_a$**

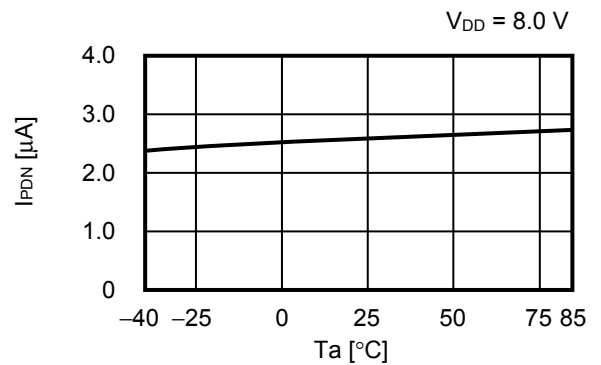

**2. 3  $I_{OPE}$  vs.  $V_{DD}$**

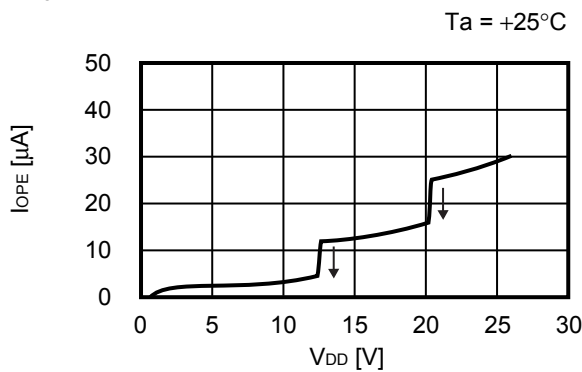

**3. Delay time**

**3.1  $t_{CU}$  vs.  $T_a$**

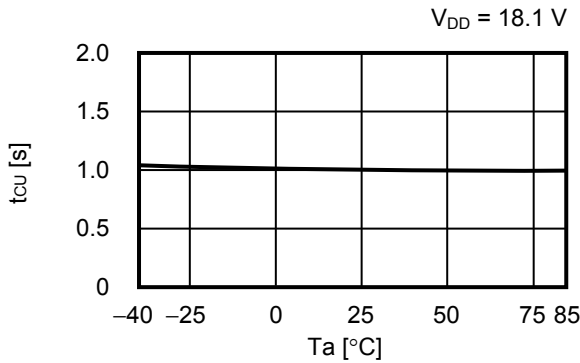

**3.2  $t_{DL}$  vs.  $T_a$**

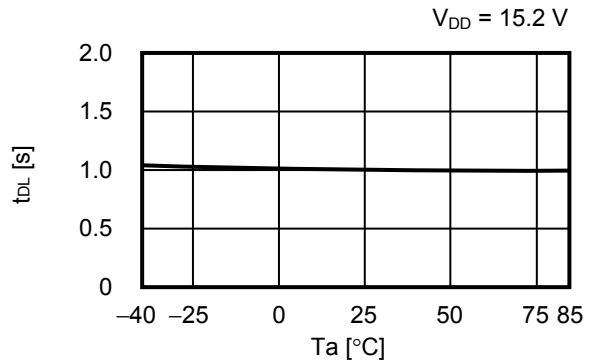

**4. Output current**

**4.1  $I_{COL}$  vs.  $V_{DD}$**

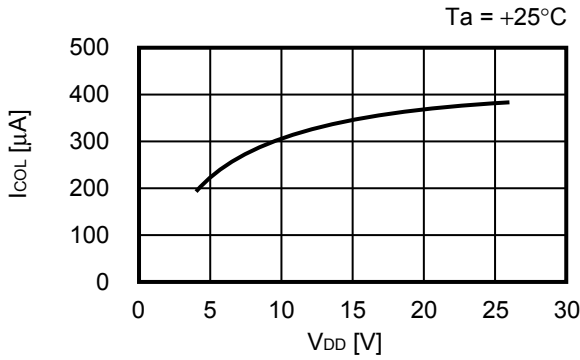

**4.2  $I_{COH}$  vs.  $V_{DD}$**

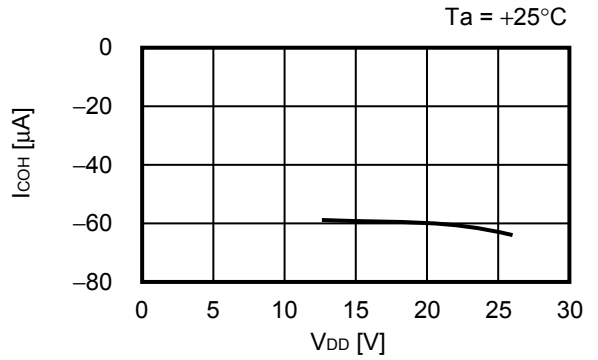

**4.3  $I_{DOL}$  vs.  $V_{DD}$**

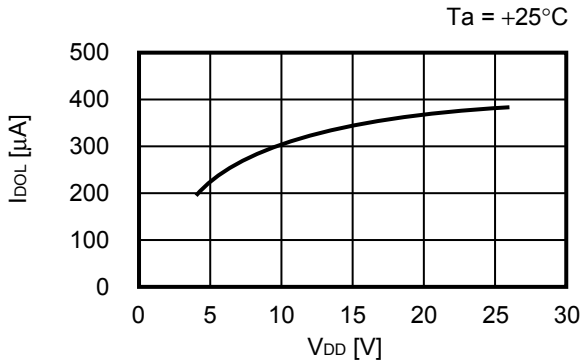

**4.4  $I_{DOH}$  vs.  $V_{DD}$**

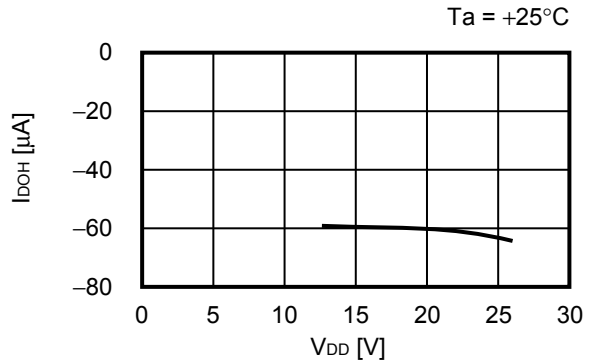

**5. Output voltage**

**5.1  $V_{COH}$  vs.  $V_{DD}$**

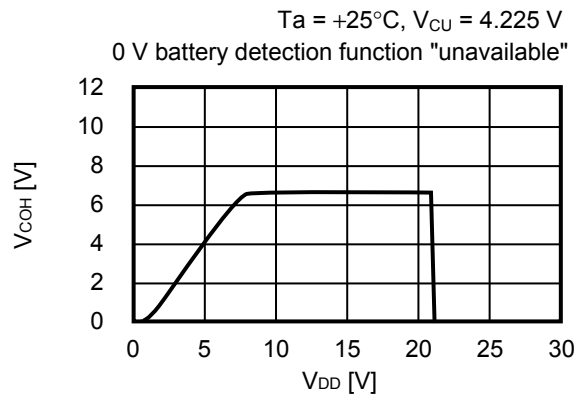

**5.2  $V_{DOH}$  vs.  $V_{DD}$**

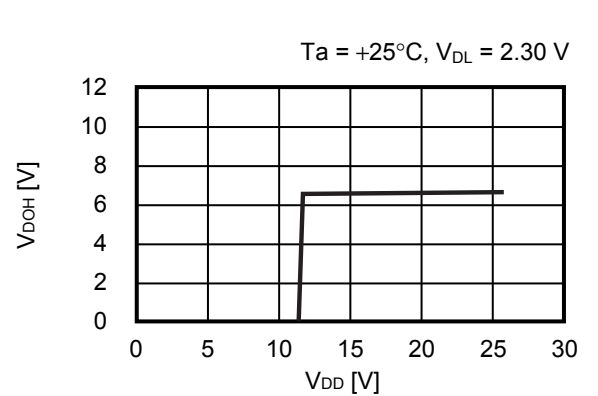



No. FT016-A-P-SD-1.2

TITLE	TSSOP16-A-PKG Dimensions
No.	FT016-A-P-SD-1.2
ANGLE	
UNIT	mm
SII Semiconductor Corporation	





No. FT016-A-C-SD-1.1

TITLE	TSSOP16-A-Carrier Tape
No.	FT016-A-C-SD-1.1
ANGLE	
UNIT	mm
SII Semiconductor Corporation	



Enlarged drawing in the central part

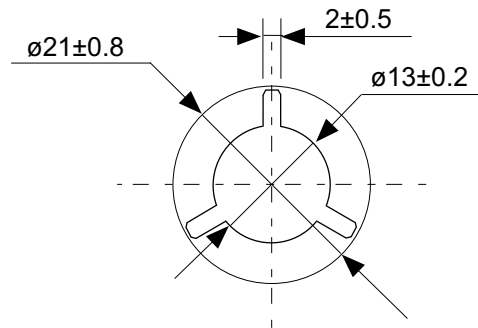

No. FT016-A-R-S1-1.0

TITLE	TSSOP16-A- Reel		
No.	FT016-A-R-S1-1.0		
ANGLE		QTY.	4,000
UNIT	mm		
SII Semiconductor Corporation			

## Disclaimers (Handling Precautions)

1. All the information described herein (product data, specifications, figures, tables, programs, algorithms and application circuit examples, etc.) is current as of publishing date of this document and is subject to change without notice.
2. The circuit examples and the usages described herein are for reference only, and do not guarantee the success of any specific mass-production design.  
SII Semiconductor Corporation is not responsible for damages caused by the reasons other than the products or infringement of third-party intellectual property rights and any other rights due to the use of the information described herein.
3. SII Semiconductor Corporation is not responsible for damages caused by the incorrect information described herein.
4. Take care to use the products described herein within their specified ranges. Pay special attention to the absolute maximum ratings, operation voltage range and electrical characteristics, etc.  
SII Semiconductor Corporation is not responsible for damages caused by failures and/or accidents, etc. that occur due to the use of products outside their specified ranges.
5. When using the products described herein, confirm their applications, and the laws and regulations of the region or country where they are used and verify suitability, safety and other factors for the intended use.
6. When exporting the products described herein, comply with the Foreign Exchange and Foreign Trade Act and all other export-related laws, and follow the required procedures.
7. The products described herein must not be used or provided (exported) for the purposes of the development of weapons of mass destruction or military use. SII Semiconductor Corporation is not responsible for any provision (export) to those whose purpose is to develop, manufacture, use or store nuclear, biological or chemical weapons, missiles, or other military use.
8. The products described herein are not designed to be used as part of any device or equipment that may affect the human body, human life, or assets (such as medical equipment, disaster prevention systems, security systems, combustion control systems, infrastructure control systems, vehicle equipment, traffic systems, in-vehicle equipment, aviation equipment, aerospace equipment, and nuclear-related equipment), excluding when specified for in-vehicle use or other uses. Do not use those products without the prior written permission of SII Semiconductor Corporation. Especially, the products described herein cannot be used for life support devices, devices implanted in the human body and devices that directly affect human life, etc.  
Prior consultation with our sales office is required when considering the above uses.  
SII Semiconductor Corporation is not responsible for damages caused by unauthorized or unspecified use of our products.
9. Semiconductor products may fail or malfunction with some probability.  
The user of these products should therefore take responsibility to give thorough consideration to safety design including redundancy, fire spread prevention measures, and malfunction prevention to prevent accidents causing injury or death, fires and social damage, etc. that may ensue from the products' failure or malfunction.  
The entire system must be sufficiently evaluated and applied on customer's own responsibility.
10. The products described herein are not designed to be radiation-proof. The necessary radiation measures should be taken in the product design by the customer depending on the intended use.
11. The products described herein do not affect human health under normal use. However, they contain chemical substances and heavy metals and should therefore not be put in the mouth. The fracture surfaces of wafers and chips may be sharp. Take care when handling these with the bare hands to prevent injuries, etc.
12. When disposing of the products described herein, comply with the laws and ordinances of the country or region where they are used.
13. The information described herein contains copyright information and know-how of SII Semiconductor Corporation.  
The information described herein does not convey any license under any intellectual property rights or any other rights belonging to SII Semiconductor Corporation or a third party. Reproduction or copying of the information described herein for the purpose of disclosing it to a third-party without the express permission of SII Semiconductor Corporation is strictly prohibited.
14. For more details on the information described herein, contact our sales office.

1.0-2016.01

