

THIS DRAWING IS UNPUBLISHED. RELEASED FOR PUBLICATION
 © COPYRIGHT - By - ALL RIGHTS RESERVED.

LOC		DIST		REVISIONS			
P	LTR	DESCRIPTION	DATE	DWN	APVD		
FT	0	T1	REVISED PER ECO-11-004917	11MAR11	RK	HMR	

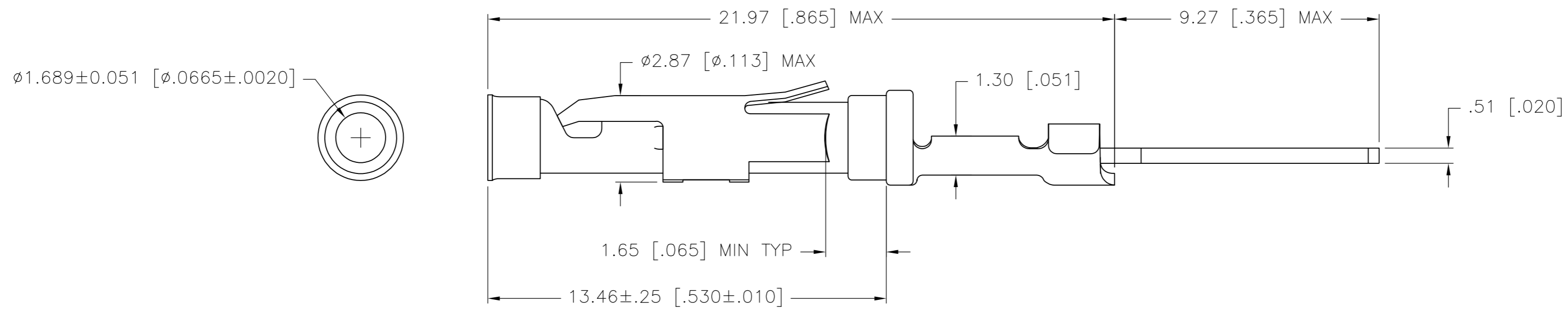
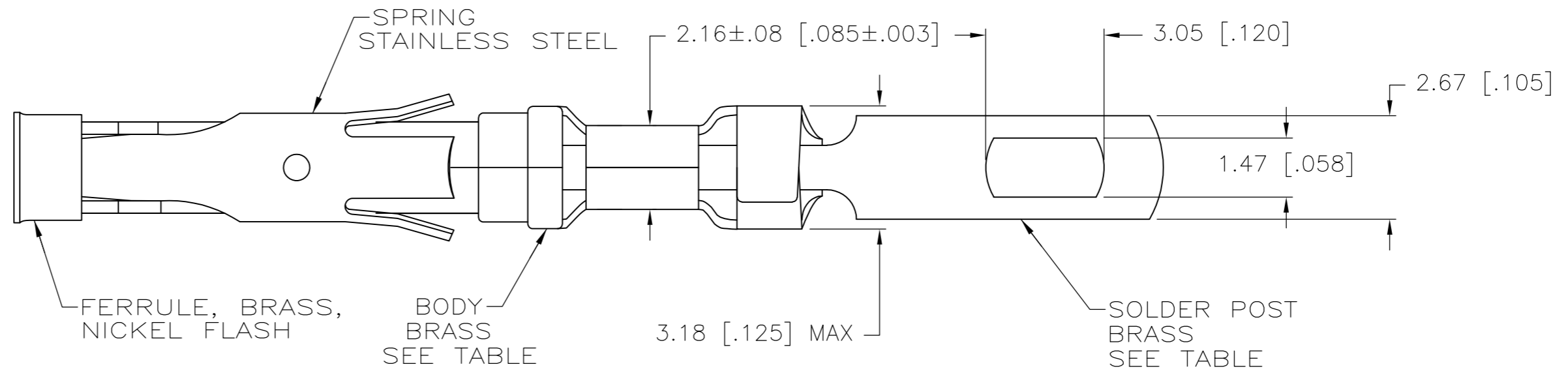

- ① 0.76µm [.000030] MIN GOLD PER MIL-G-45204 ON MATING END FOR A LENGTH OF 5.08 [.200] MIN WITH A UNIFORM GRADIENT TO 0.25µm [.000010] MIN GOLD PER MIL-G-45204 ON THE REMAINDER OVER 0.76µm [.000030] MIN NICKEL PER QQ-N-290.
- ② 1.27µm [.000050] MIN TIN-LEAD PER MIL-T-10727 OVER 0.76µm [.000030] MIN NICKEL PER QQ-N-290.
- ③ 2.54µm [.000100] MIN TIN-LEAD PER MIL-T-10727 OVER 1.27µm [.000050] MIN NICKEL PER QQ-N-290.
- ④ 2.54µm [.000100] MIN TIN PER MIL-T-10727 OVER 1.27µm [.000050] MIN NICKEL PER QQ-N-290.
- ⑤ 1.27µm [.000050] MIN TIN PER MIL-T-10727 OVER 0.76µm [.000030] MIN NICKEL PER QQ-N-290.

SMALL PACK	④	①	202237-8
STANDARD	④	①	202237-7
SMALL PACK	④	⑤	202237-6
STANDARD	④	⑤	202237-5
SMALL PACK	③	②	202237-4
SMALL PACK	③	①	202237-3
STANDARD	③	②	202237-2
STANDARD	③	①	202237-1
PACKAGING TYPE	SOLDER POST FINISH	BODY FINISH	PART NO

THIS DRAWING IS A CONTROLLED DOCUMENT.		DWN R.SHIREY 31JUL91	TE TE Connectivity	
DIMENSIONS: mm [INCHES]		CHK R.STONE 20SEP91		
TOLERANCES UNLESS OTHERWISE SPECIFIED:		APVD J.WESTMAN 20SEP91	NAME SOCKET ASSEMBLY, SOLDER POST, TYPE III+	
0 PLC ± -		PRODUCT SPEC -	SIZE A2	
1 PLC ± -		APPLICATION SPEC -	CAGE CODE 00779	DRAWING NO C=202237
2 PLC ± 0.13[.005]		WEIGHT -	RESTRICTED TO -	
3 PLC ± -		CUSTOMER DRAWING	SCALE 8:1	SHEET 1 of 1
4 PLC ± -			REV T1	
ANGLES ± -				
FINISH SEE CALLOUTS				