



All numerical values are in metric units [with U.S. customary units in brackets]. Dimensions are in millimeters [and inches]. Unless otherwise specified, dimensions have a tolerance of ± 0.13 [$\pm .005$] and angles have a tolerance of $\pm 2^\circ$. Figures and illustrations are for identification only and are not drawn to scale.

1. INTRODUCTION

This specification covers the requirements for application of CPC Series 45 System for use in harsh environments for panel mount applications. The system consists of a plug kit and a receptacle kit; both available in shielded or unshielded for terminating to cable or for use as a pass-through. The shielded plug kit contains a modular plug with a metal outer shell; the unshielded is plastic. The shielded receptacle kit contains a shield to be assembled onto the jack assembly.

When corresponding with personnel, use the terminology provided in this specification to facilitate your inquiries for information. Basic terms and features of this product are provided in Figure 1.

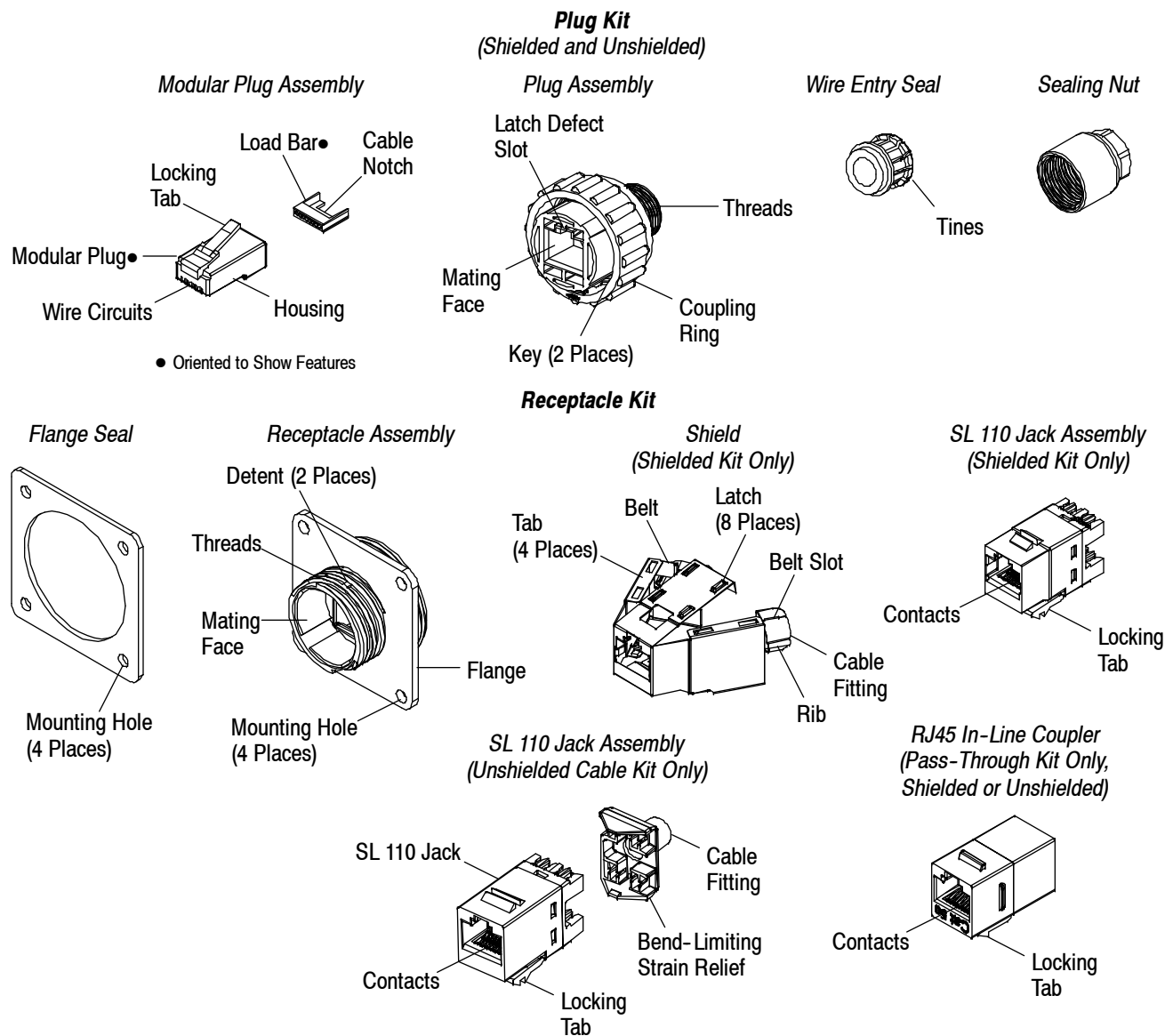

Figure 1

1.1. Plug Kit

Each plug kit consists of a modular plug assembly, plug assembly, wire entry seal, and sealing nut.

The modular plug assembly includes a load bar which is used to maintain the proper alignment of the conductors to the contacts for termination. The modular plug is terminated using the insulation piercing technique. The modular plug features two internal strain reliefs to protect the plug-to-cable and terminal-to-conductor interface from damage when subjected to pulling or bending forces—the primary strain relief grips the jacket and the secondary strain relief acts on the conductors. The plug assembly is used to house the modular plug assembly. The wire entry seal and sealing nut are used to prevent elements from entering the modular plug and to provide a strain relief for the cable. The coupling ring is used to secure the modular plug to the mated jack assembly or coupler.

The modular plug assembly is available in loose piece for terminating with manual or pneumatically-powered tools, and continuous strip form for terminating with semi-automatic machines.

1.2. Receptacle Kit

Each receptacle kit consists of a receptacle assembly, flange seal, and jack assembly or in-line coupler. The shielded kit includes a shield with a strain relief for the cable, and the unshielded kit includes a bend-limiting strain relief.

The receptacle assembly is used to house the jack assembly or coupler, and to mount the assembly to a panel using customer-supplied screws. The jack assembly and coupler each feature a locking tab that secures it to the receptacle assembly. The receptacle kit is designed to be front or rear panel-mounted. The jack assembly and coupler each mate with the modular plug.

2. REFERENCE MATERIAL

2.1. Revision Summary

Revisions to this application specification include:

- Modified plug assembly and wire entry seal
- Changed torque value in Figure 8

2.2. Customer Assistance

Reference Product Base Part Number 1546907 and Product Code K360 are representative of CPC Series 45 system. Use of these numbers will identify the product line and expedite your inquiries through a service network established to help you obtain product and tooling information. Such information can be obtained through a local representative or, after purchase, by calling PRODUCT INFORMATION at the number at the bottom of page 1.

2.3. Drawings

Customer Drawings for product part numbers are available from the service network. If there is a conflict between the information contained in the Customer Drawings and this specification or with any other technical documentation supplied, call PRODUCT INFORMATION at the number at the bottom of page 1.

2.4. Specifications

Product Specifications (108-series) provide product performance and test information. Specifications available that pertain to this product are:

- | | |
|----------|---------------|
| 108-2203 | CPC Series 45 |
| 108-1163 | Modular Plugs |

2.5. Standards

Standards and publications developed by the International Electrotechnical Commission (IEC) and Telecommunications Industry Association and Electronic Industries Alliance (TIA/EIA) provide industry test and performance requirements. Documents available which pertain to this product are:

IEC 60529, "Degrees of Protection Provided By Enclosures," IP Code 67

TIA/EIA-568, "Commercial Building Telecommunications Cabling Standards"

2.6. Instructional Material

Instruction Sheets (408-series) provide product assembly instructions or tool setup and operation procedures. Documents available which pertain to this product are:

A. Product

408-8417 SL Series 110Connect Modular Jacks

408-8602 Shielded SL Series 110Connect Modular Jacks

408-8949 CPC Series 45 Shielded Receptacle Kit

408-8950 CPC Series 45 Unshielded Receptacle Kit

408-8951 CPC Series 45 Plug Kits

408-10091 CPC Series 45 Unshielded Pass-Through Receptacle Kit

408-10137 CPC Series 45 Shielded Pass-Through Receptacle Kit 1986172-1

B. Tooling

408-8858 Tool Kits 1725150-[]

408-9743 Terminating Module 1-856196-1

408-9767 Modular Plug Hand Tool (Premium Grade) 231652-[]

408-9919 Modular Plug Single Terminators 354711-[] and Tooling Kits 354714-[]

409-10010 Modular Plug Dual Terminator 1320840-[]

3. REQUIREMENTS

3.1. Cable Selection

A. Plug Kit

The modular plug will accept Category 5e round cable with the following specifications:

Cable type: 8-conductor

Conductor size: 24 or 26 AWG

Conductor type: solid or 7-strand copper

Conductor insulation diameter: 0.99 [.039] maximum

Cable jacket diameter range:

RJ-45 plug accepts: 4.83 through 5.59 [.190 through .220] (single jacket)

Cable fitting accepts: 4.6 through 6.0 [.18 through .236] (double jacket)

B. Receptacle Kit

The SL 110 jack (shielded and unshielded) will accept cable with the following specifications:

Cable type: 4-pair, round

Conductor type and size:

Solid sizes 24-22 AWG

Twisted stranded size 24 AWG

Conductor insulation diameter: 1.27 [.050] maximum

Shield type: Foil or braid with drain wire

3.2. Cable Preparation

A. Plug Kit

1. The sealing nut (small diameter end first), wire entry seal (tines first), and plug assembly (threaded end first) must be installed onto the cable. See Figure 2, Detail A.
2. Proper strip length is necessary to insert the conductors into the contact slots of the modular plug. The recommended strip length is given in Figure 2, Detail B.



Reasonable care must be taken not to scrape or nick any part of the cable during the stripping operation. Insulation of individual conductors **MUST NOT** be cut or removed. This could result in shorted or open terminations.

For shielded cable, the shield must be folded back over the cable jacket, and the drain wire must be bent back over shield. The shield and drain wire must be trimmed to the dimension given in Figure 2, Detail B.

Cable Preparation for Plug Kit

Detail A

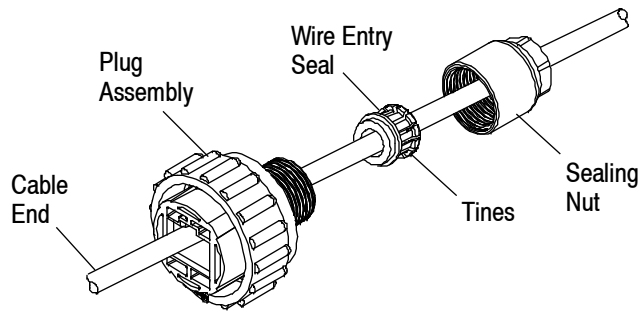

Detail B

Note: Not to Scale

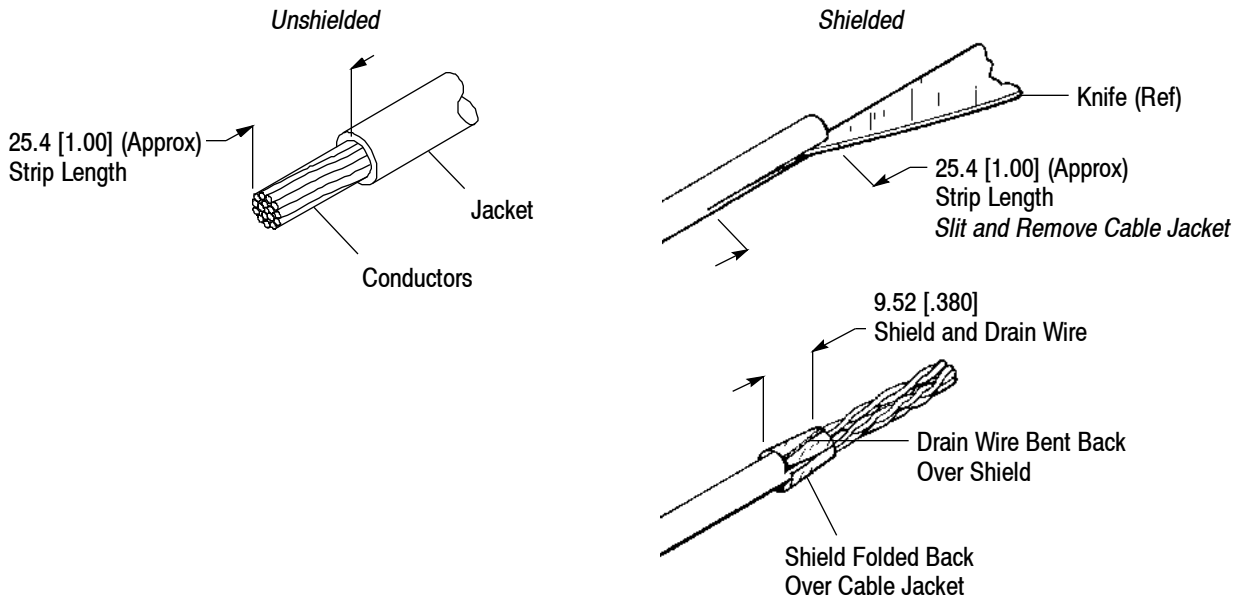

Figure 2

B. Receptacle Kit

Shielded

1. Proper strip length is necessary to insert the conductors into the contact slots of the SL 110 jack. The recommended strip length is given in Figure 3.
2. The foil or braid must be folded back over the cable jacket. If present, the clear wrapping must be removed. The drain wire must not be cut and must be wrapped a minimum of 360° around the foil or braid at the stripped end of the cable jacket to the dimension given in Figure 3.

Unshielded

1. The bend-limiting strain relief must be installed (cable fitting end first) onto the cable.
2. Proper strip length is necessary to insert the conductors into the contact slots of the SL 110 jack. The recommended strip length is given in Figure 3.

Cable Preparation for SL 110 Jack

Note: Not to Scale

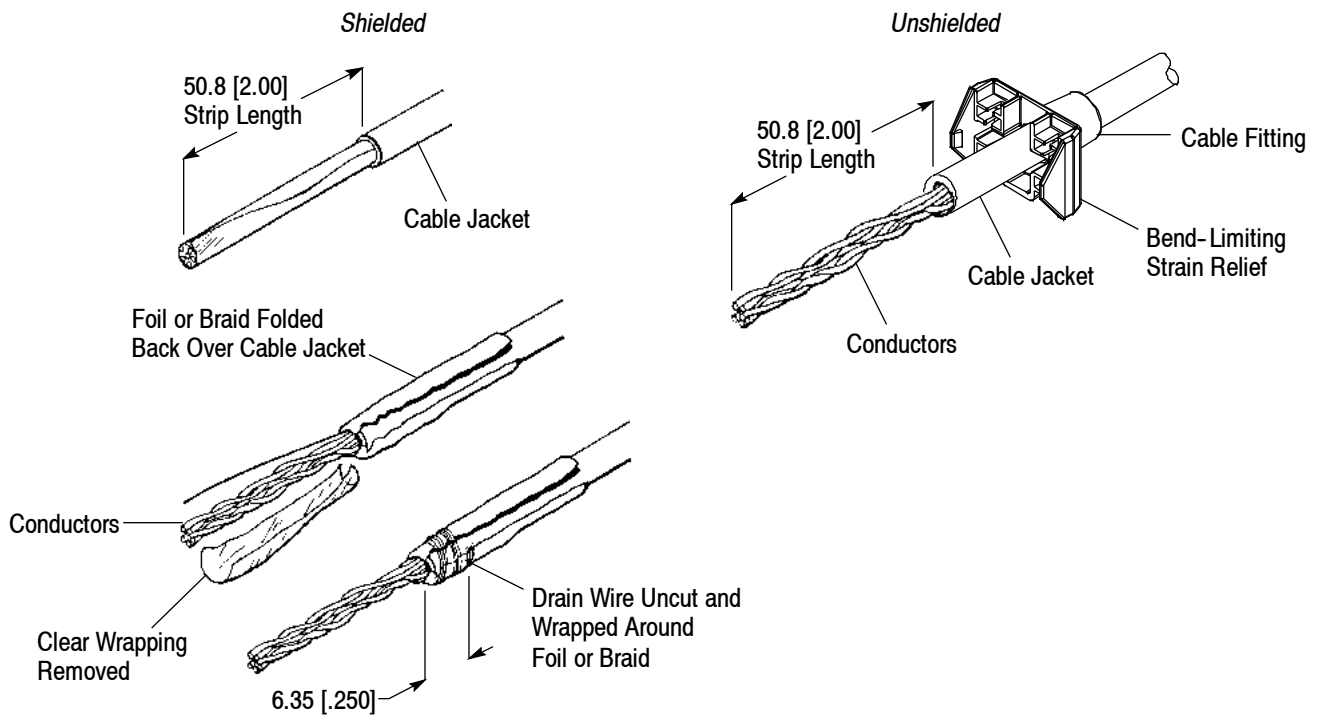
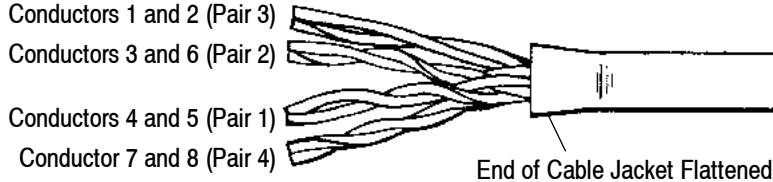
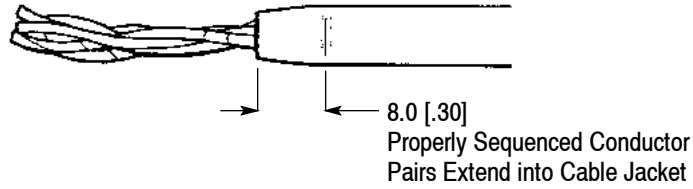
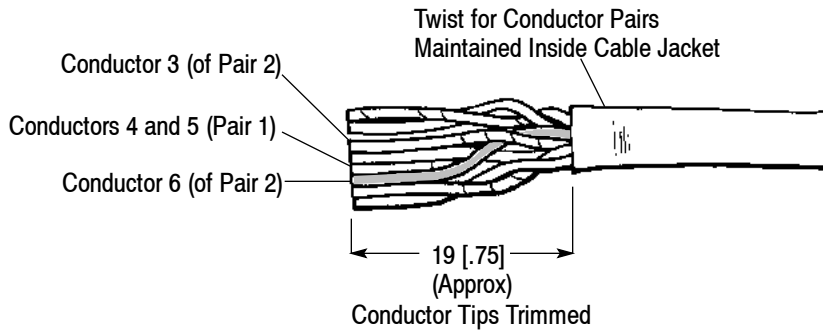
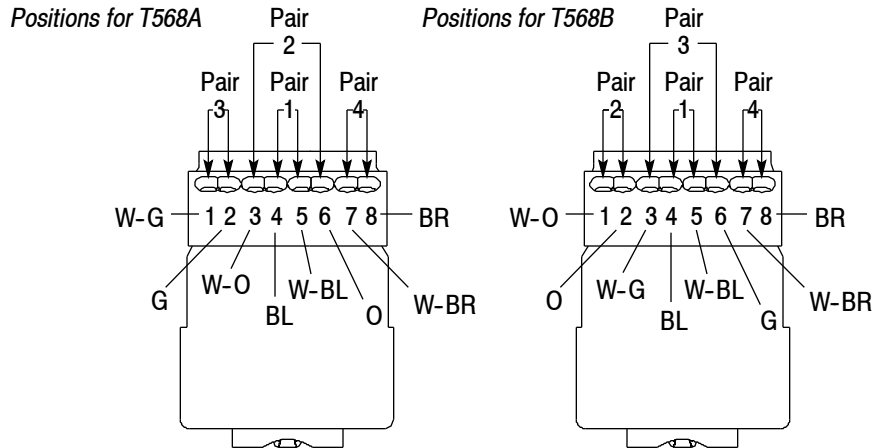

Figure 3

3.3. Conductor Positioning

1. Conductor pairs must be oriented side-by-side in the order shown in Figure 4, Detail A. The end of the cable jacket must be flattened so that the conductor pairs lay side-by-side.
2. Properly sequenced conductor pairs should extend into the cable jacket to the dimension given in Figure 4, Detail B, creating an oblong shape.
3. The conductor tips must be trimmed evenly to the dimension shown in Figure 4, Detail C. Proper orientation of conductors must be maintained.
4. The conductor pairs must be untwisted and arranged according to EIA/TIA T568A or T568B (defined in Figure 4, Detail D). IT IS CRITICAL that the the pairs are NOT untwisted inside the cable jacket. When arranging conductor pairs, IT IS IMPORTANT that Conductor 6 be crossed *over* Conductors 4 and 5 as shown in Figure 4, Detail C.

Conductor Positioning

Detail A

Detail B

Detail C

Detail D

CONDUCTOR PAIR	CONDUCTOR PAIR For Electrical Schematic		CONDUCTOR COLOR CODE (Abbreviation)	
	T568A	T568B	OPTION 1	OPTION 2
1	4	4	Blue (BL)▪	Red (R)
	5	5	White-Blue (W-BL)	Green (G)
2	3	1	White-Orange (W-O)	Black (BK)
	6	2	Orange (O)	Yellow (Y)
3	1	3	White-Green (W-G)	Blue (BL)
	2	6	Green (G)▪	Orange (O)
4	7	7	White-Brown (W-BR)	Brown (BR)
	8	8	Brown (BR)▪	Slate (S)

▪ A white marking is acceptable.

Figure 4

3.4. Termination

A. Plug Kit

1. The conductors must be inserted (maintaining arrangement) into the back (cable notch end) of the load bar until the cable jacket rests against the cable notch. The conductor twist must not enter the front of the load bar. The conductors must be trimmed evenly and square to the dimension given in Figure 5, Detail A.
2. The conductors must be retracted from the load bar so that the conductors protrude from the end of the load bar to the dimension given in Figure 5, Detail B. The top of the load bar must not be deformed.

NOTE

If the load bar is deformed, the conductor twist has entered the front of the load bar.



3. The load bar must be oriented so that the top is aligned with the contacts of the modular plug and inserted into the modular plug until it butts against the mating feature of the modular plug. The conductors must be bottomed on the wire circuits of the modular plug. The cable jacket must be against the cable notch after the load bar is fully seated. The conductors must not be exposed between the cable jacket and the top of the load bar. The ends of the conductors must be clearly visible through the front of the housing. See Figure 5, Detail C.

NOTE

If the conductors do not bottom on the wire circuits, they must be re-trimmed (after removing the load bar/cable assembly from the modular plug), and re-inserted into the modular plug. If the conductors are too short, the cable must be re-stripped.



4. The modular plug must be terminated to the cable according to the instructions included with the tooling.

B. Receptacle Kit

The SL 110 jack must be terminated to the cable according to the instructions included with the tooling.

Termination Requirements for Modular Plug

Detail A

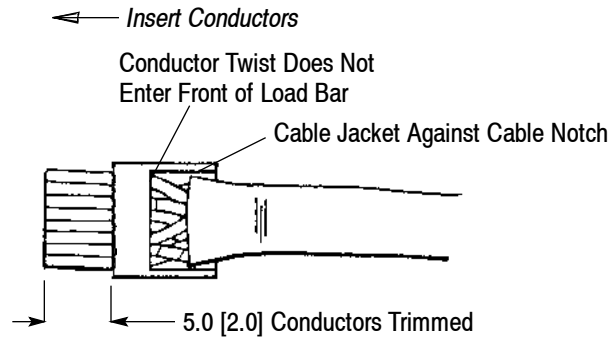

Detail B

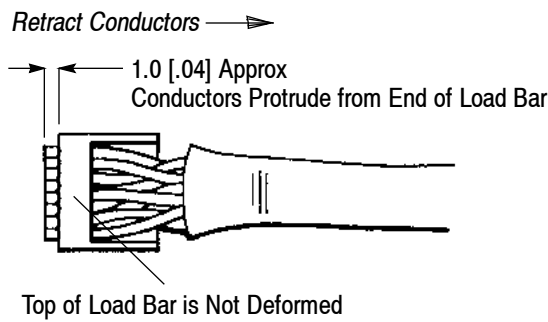

Detail C

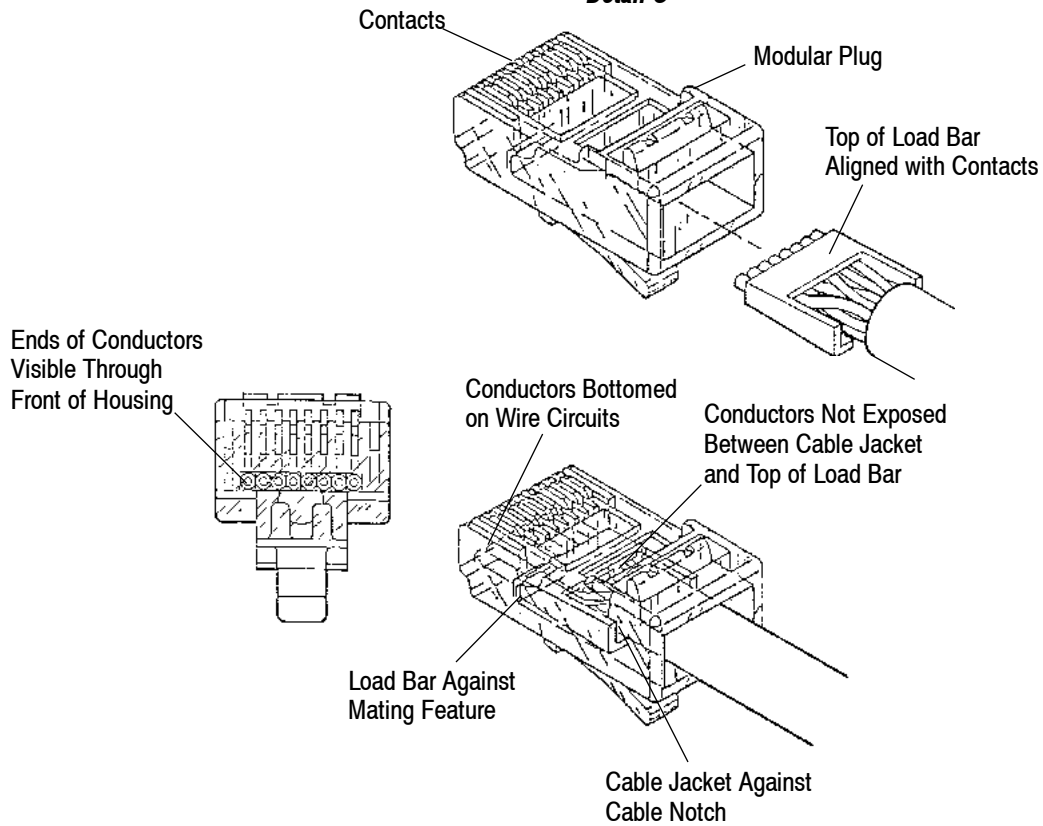



Figure 5

3.5. Inspection

A. Modular Plug

1. The end of each conductor must be within the dimension given in Figure 6. For optimum transmission performance, the end of each conductor must be bottomed on the wire circuits of the modular plug.
2. The crimp height (measured from the top of the contact to the bottom of the modular plug, not including the locking tab) must be within the dimension given in Figure 6. All contacts must be at approximately the same height.

NOTE *The crimp height must be met in order to comply with Federal Communications Commission (FCC) regulations.*



3. The primary strain relief must be fully engaged with the cable jacket, and the secondary strain relief must be fully engaged with the cable conductors. Both strain reliefs must be fully engaged to isolate the termination area from external forces applied to the cable. It is acceptable for the primary strain relief to cut into the jacket as long as the conductor insulation is not compromised.

NOTE *The primary and secondary strain reliefs can be visually inspected through the side of the modular plug.*



Inspection of Terminated Modular Plug

Cross-Section

Note: Not to Scale

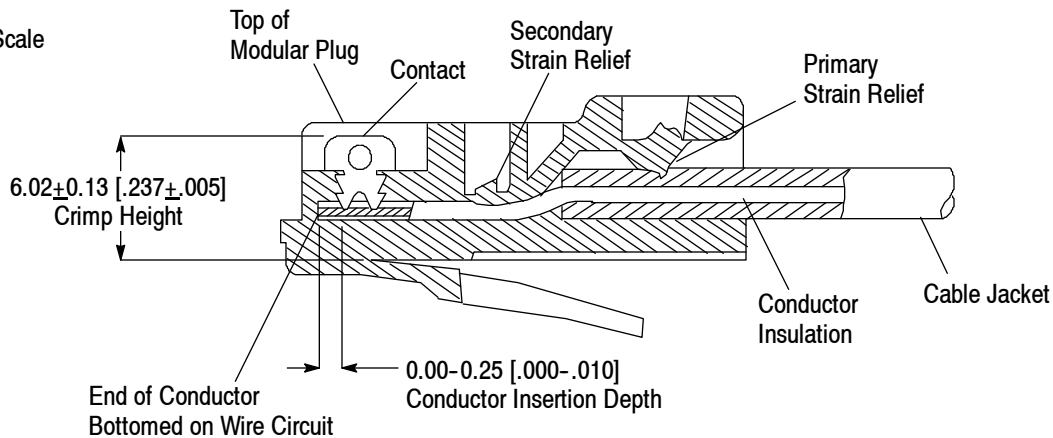

Figure 6

B. SL 110 Jack

All conductors must be bottomed in the wire slots, and there must be no excess or loose conductors. Conductor twist must be maintained to within the dimension given in Figure 7.

3.6. Electrical Testing

The modular plug and SL 110 jack must be tested for continuity and proper conductor mapping using company-approved testing procedures and safety practices.

Inspection of Terminated SL 110 Jack

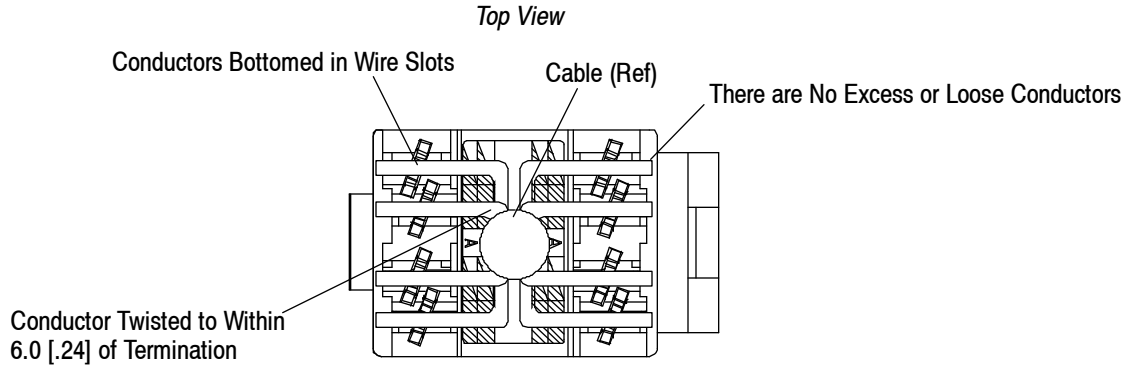

Figure 7

3.7. Assembly

A. Plug Kit

1. The modular plug must be fully seated in the plug assembly with the modular plug protruding from the mating face of the plug assembly to the dimension given in Figure 8, Detail A.
2. The wire entry seal must be against the threads of the plug assembly.
3. The sealing nut must be against the shoulder of the plug assembly and must be tight to the torque given in Figure 8, Detail B.

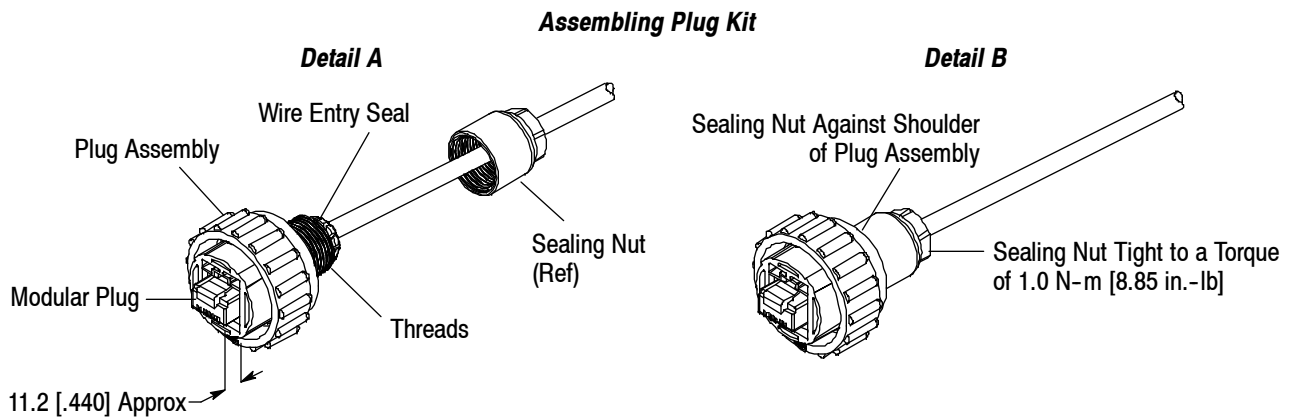

Figure 8

B. Receptacle Kit

Shielded

1. The shield must be installed onto the SL 110 jack with the following requirements (refer to Figure 9, Detail A):
 - a. each latch must be engaged with the hole of its corresponding tab
 - b. each belt must be completely through its corresponding belt latch and bent away from the cable
 - c. the ribs of the cable fitting must be pinched so that the cable fitting is tight around the cable foil or braid
 - d. excess foil or braid must be removed from around the end of the cable fitting
2. The SL 110 jack must be fully seated in the receptacle assembly.

3. The flange seal must be flat against the flange of the receptacle assembly—fitted over the front (mating face) of the receptacle assembly for back panel mount or over the back of the receptacle assembly for front panel mount. Refer to Figure 9, Detail B.

Assembling Shielded Receptacle Kit

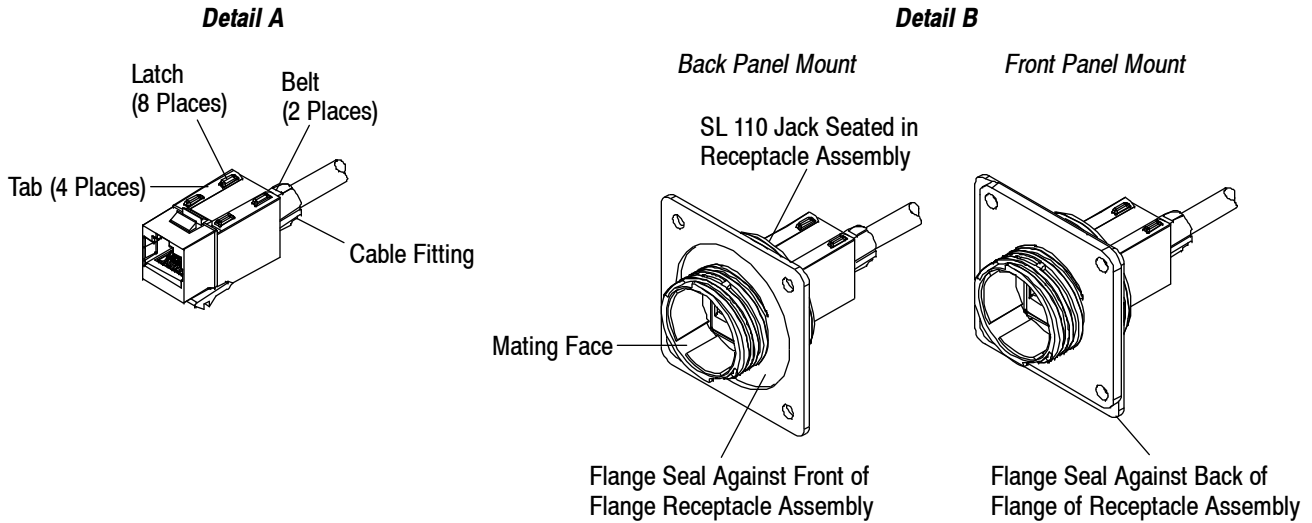

Figure 9

Unshielded Cable

1. The latches of the bend-limiting strain relief must be engaged with the tabs of the SL 110 jack. The length of the assembly must meet the dimension given in Figure 10, Detail A.
2. The SL 110 jack must be fully seated in the receptacle assembly (the locking tab of the jack must be engaged with the wide slot of the receptacle assembly).
3. The flange seal must be flat against the flange of the receptacle assembly—fitted over the front (mating face) of the flange for back panel mount or over the back of the flange for front panel mount. Refer to Figure 10, Detail B.

Assembling Unshielded Cable Receptacle Kit

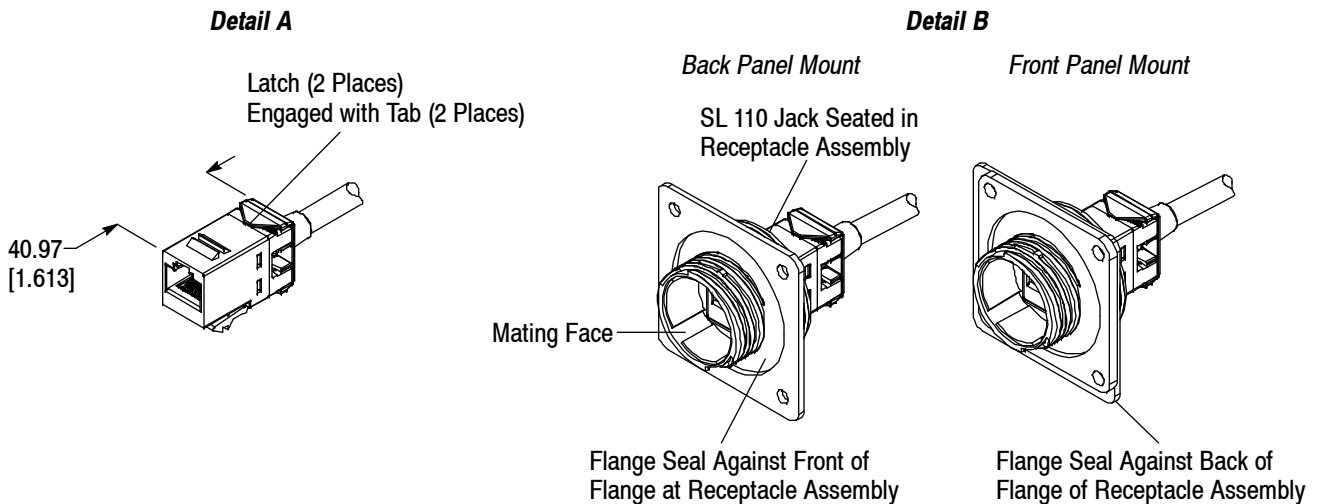

Figure 10

Unshielded Pass-Through

1. The coupler must be fully seated in the receptacle assembly (the locking tab of the coupler must be engaged with the wide slot of the receptacle assembly).
2. The flange seal must be flat against the flange of the receptacle assembly—fitted over the front (mating face) of the receptacle assembly for back panel mount or over the back of the receptacle assembly for front panel mount. Refer to Figure 11.

Assembling Unshielded Pass-Through Receptacle Kit

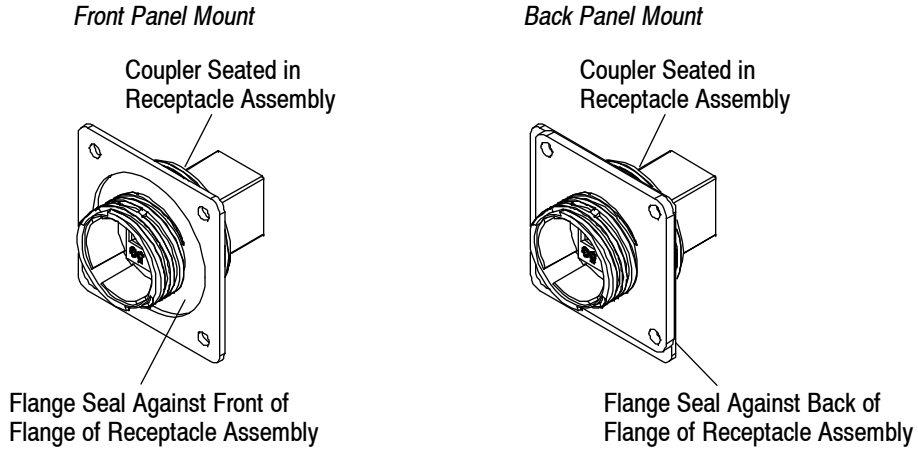

Figure 11

3.8. Panel

A. Cutout

The maximum panel thickness shall be 3.18 [.125]. The panel must be cut using the dimensions provided in Figure 12.

Recommended Panel Cutout

Note: Not to Scale

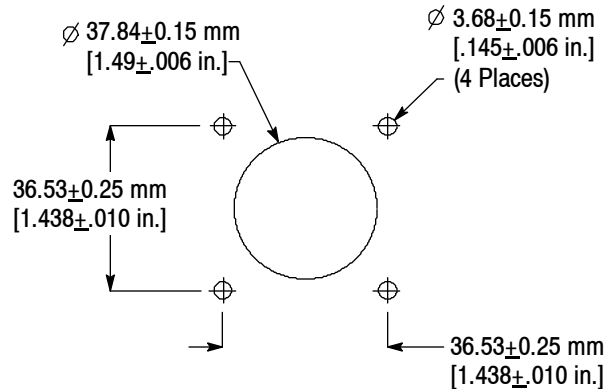

Figure 12

B. Mounting (Figure 13)

The receptacle assembly is designed for front or back panel-mount applications. The receptacle assembly must be installed onto the panel with the following requirements:

1. The flange seal must be flat against the panel (front of the panel for front panel mount and back of the panel for back panel mount).
2. Four commercially-available No. 4 screws must be used to secure the receptacle assembly to the panel. The screws must be tight.

Panel Mounting

Note: Shielded Kit is Shown; Same Requirements Apply for Unshielded Kits

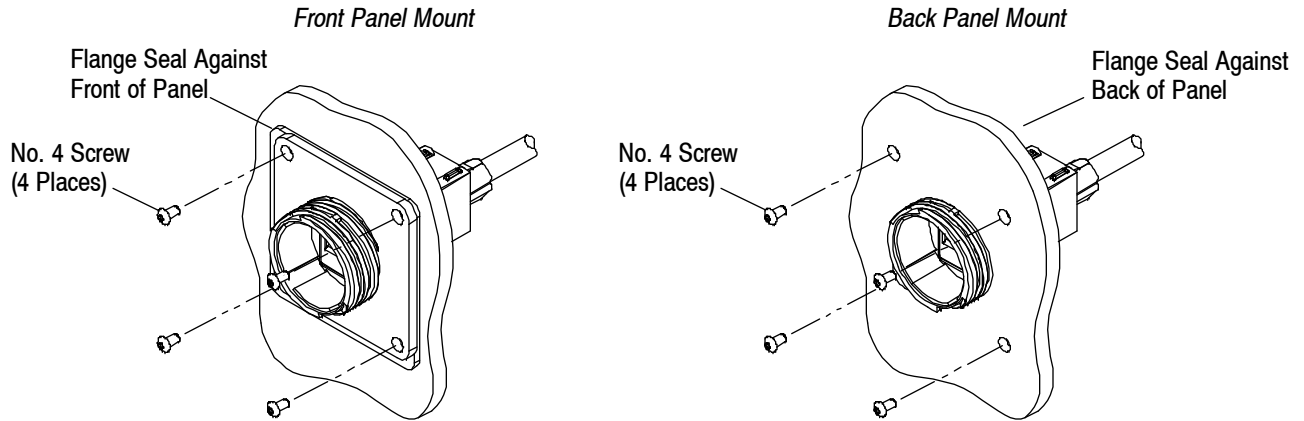

Figure 13

3.9. Engagement

Properly engaged connectors must have the following requirements:

1. The locking tab of the modular plug must be fully seated in the small slot of the jack or in-line coupler.
2. The coupling ring of the plug assembly must be engaged with the threads on the mating face of the receptacle assembly. During engagement, the keys of the coupling ring must slide into the detents in the threads of the receptacle assembly.
3. The length of the engaged connectors, measured from the sealing nut to the cable fitting (shielded kit or unshielded cable kit) or the cable end of the in-line coupler (unshielded pass-through kit), must be within the dimension given in Figure 14.

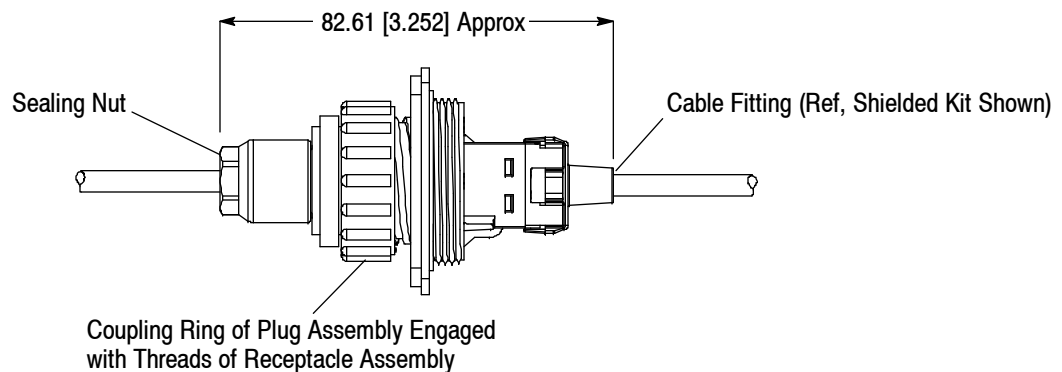

Figure 14

3.10. Repair

After a modular plug or SL 110 jack is terminated, it must not be re-terminated. Plugs and jacks must not be re-used by removing the cable. The plug assembly must not be re-used by removing the sealing nut. Damaged or defective components must not be used.

4. QUALIFICATION

The modular plug is Listed by Underwriters Laboratories Inc. (UL) in File E 81956 and Certified by CSA International in File LR 7189A.

5. TOOLING

Tooling part numbers and instructional material packaged with the tooling are shown in Figure 15.

5.1. Tools for Terminating the Modular Plug

The modular plug single terminator is a pneumatically-powered, bench-mounted tool controlled by a foot valve. The modular plug hand tool consists of a handle with a head that holds a die assembly.

The dual modular plug terminator is a pneumatically-powered, bench-mount machine that uses the terminating module to terminate the modular plug to cable two at a time to create a cable assembly. During termination, the tool tests the assembly for electrical circuit continuity. The terminator is actuated by a foot switch.

5.2. Crimp Height Gage

The crimp height gage can be used to check the crimp height of the terminated modular plug. This gage consists of a nest and a GO/NO-GO spanner.

5.3. Tools for Terminating the SL 110 Jack

The tool kit contains a hand tool capable of stripping the cable and terminating the jack. A lacing fixture is available for use with the tool.

The impact tool is equipped with a punch-down mechanism to provide the force required to insert and trim the conductors. Hand lacing is required when using this tool.

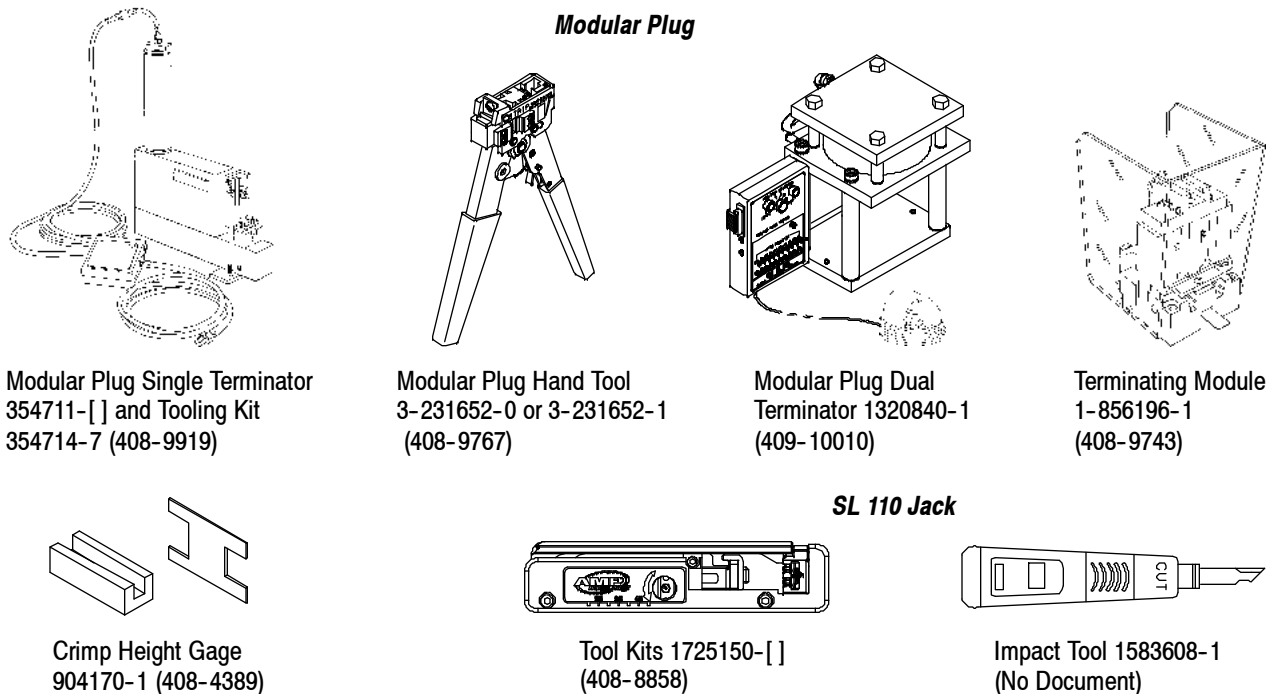

Figure 15

6. VISUAL AID

The illustration below shows a typical application of CPC Series 45 system. This illustration should be used by production personnel to ensure a correctly applied product. Applications which DO NOT appear correct should be inspected using the information in the preceding pages of this specification and in the instructional material shipped with the product or tooling.

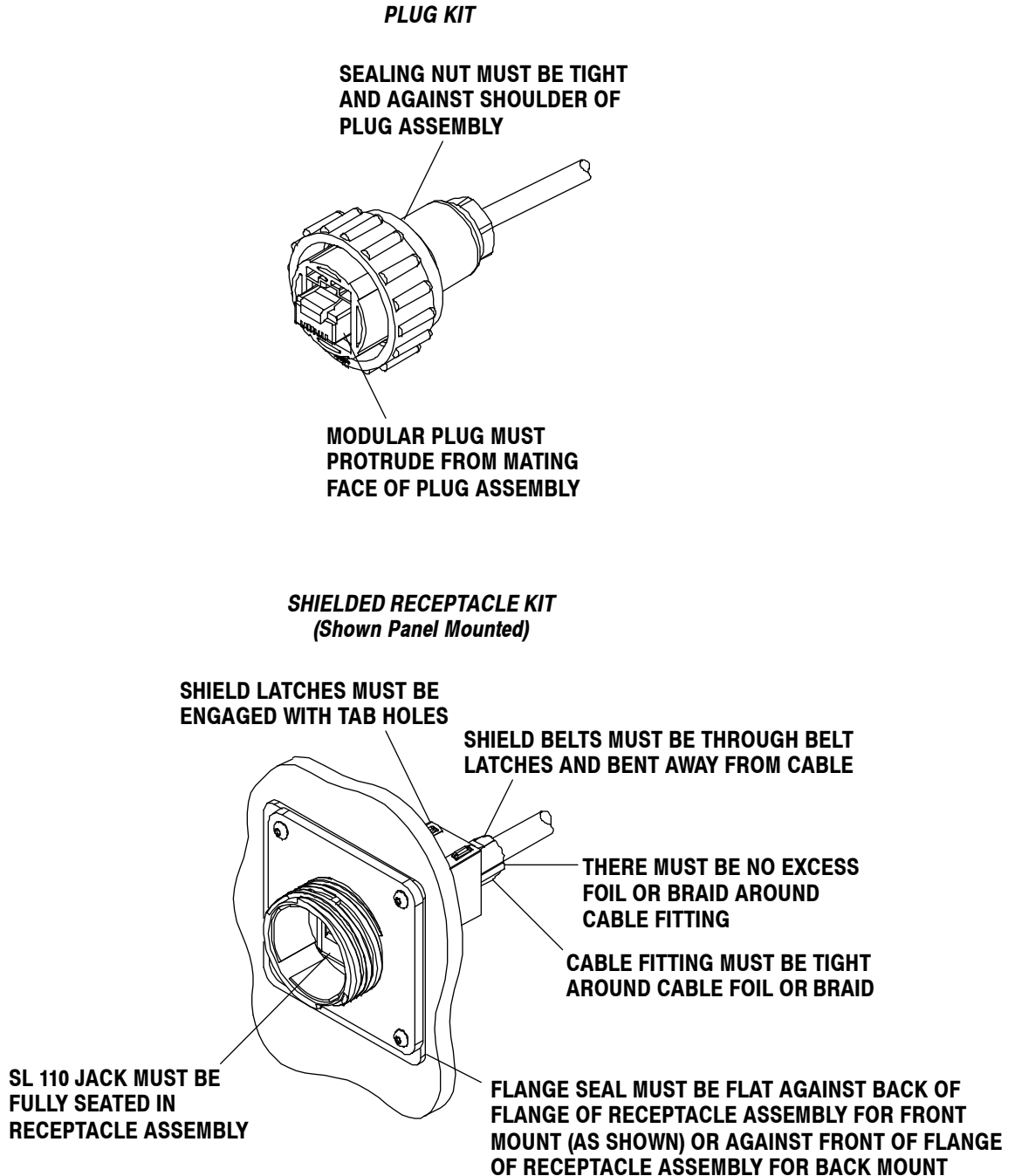
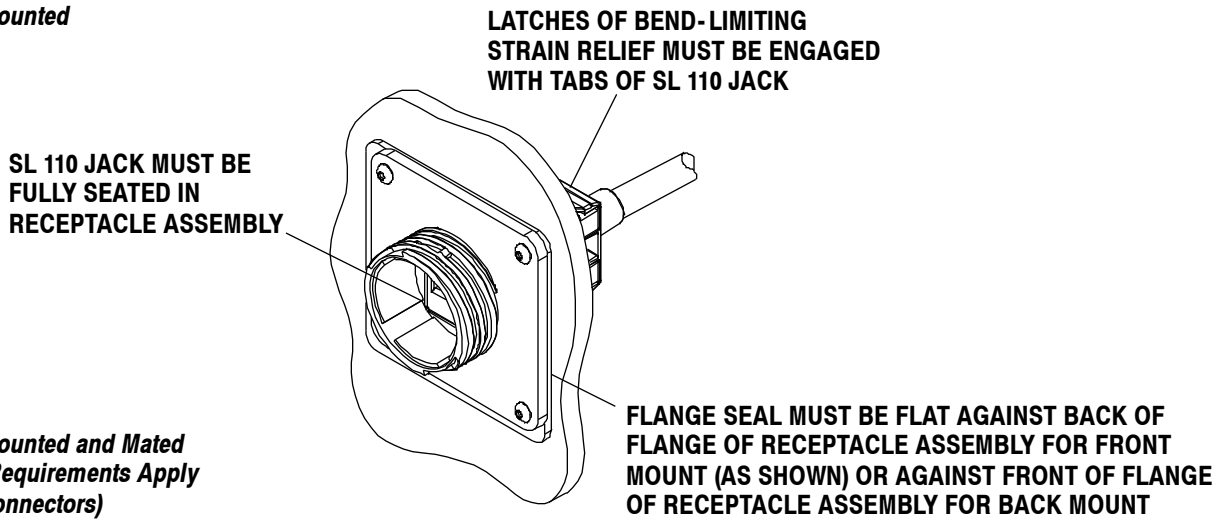

FIGURE 16. VISUAL AID (CONT'D)

UNSHIELDED CABLE RECEPTACLE KIT

Panel Mounted



**Panel Mounted and Mated
(Same Requirements Apply to All Connectors)**

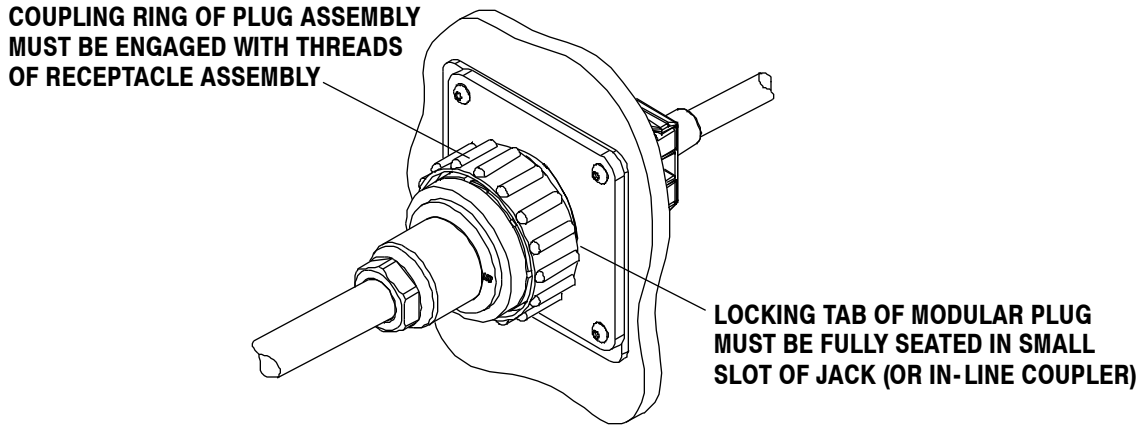

**UNSHIELDED PASS-THROUGH RECEPTACLE KIT
(Shown Panel Mounted)**

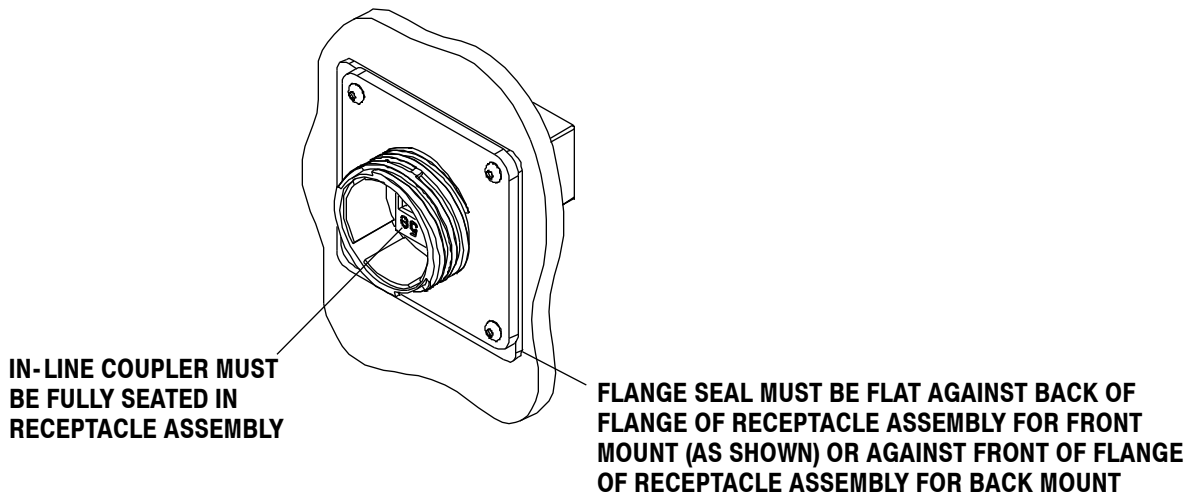

FIGURE 16. VISUAL AID (END)