

# HC2LP

## Low profile, high current power inductors

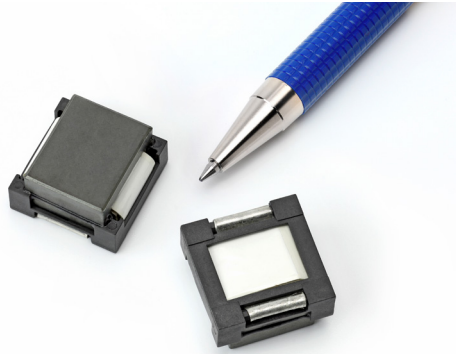

### Product description

- Compact footprint
- Designed for high density, high current/low voltage applications
- Foil technology that adds higher reliability factor over the traditional magnet wire used for higher frequency circuit designs
- Frequency Range up to 1MHz
- Ferrite core material

### Applications

- Distributed power systems DC-DC converters
- General-purpose low voltage supplies
- Computer systems
- Servers
- Point of Load (POL) converters
- Industrial Equipment
- Networking/Telecom power supplies

### Environmental data

- Storage temperature range (component): -40°C to +125°C
- Operating temperature range: -40°C to +125°C (ambient + self-temperature rise).
- Solder reflow temperature: J-STD-020D compliant.



**Product specifications**

Part number	OCL <sup>1</sup> (μH) ±20%	I <sub>rms</sub> <sup>2</sup> amps (approx.)	I <sub>sat</sub> <sup>3</sup> amps (approx.)	DCR <sup>4</sup> (Ω) maximum @ 20°C	Volt-μsec <sup>5</sup> (V-μs)
HC2LP-R47-R	.52	52.9	63.75	.0006	6.87
HC2LP-R68-R	.63	52.9	50.00	.0006	6.87
HC2LP-1R0-R	1.15	33.0	42.50	.0013	10.31
HC2LP-2R2-R	2.00	24.3	31.90	.0023	13.75
HC2LP-4R7-R	4.55	17.0	21.25	.0046	20.62
HC2LP-6R0-R	6.00	17.0	16.50	.0046	20.62

- Open Circuit Inductance Test Parameters: 300kHz, 0.250 Vrms, 0.0 Adc
- DC current for an approximate temperature change of 40°C without core loss. Derating is necessary for AC currents. PCB layout, trace thickness and width, air-flow and proximity of other heat generating components will affect the temperature rise. It is recommended that the temperature of the part not exceed 125°C under worst case operating conditions verified in the end application.
- Peak current for approximately 30% rolloff.
- Values @ 20°C
- Applied Volt-Time product (V-μs) across the inductor. This value represents the applied V-μs at 300kHz necessary to generate a core loss equal to 10% of the total losses for 40°C temperature rise.

**Dimensions—mm**

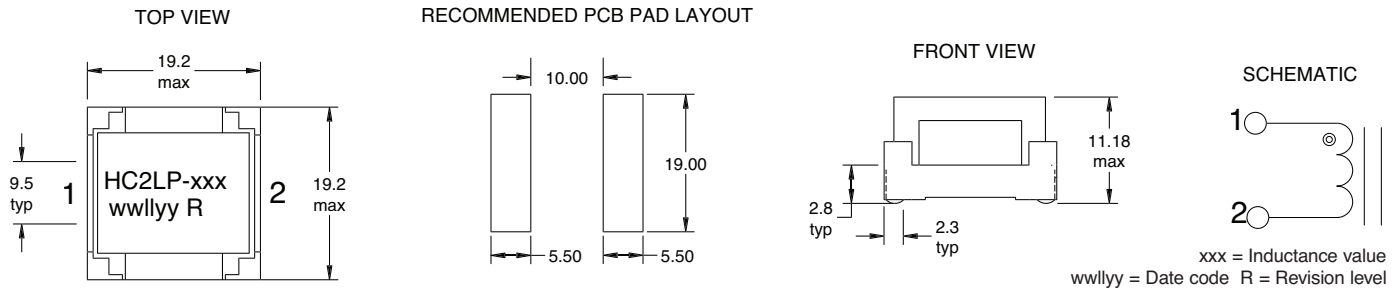

**Packaging information (mm)**

Supplied in tape and reel packaging, 130 parts per 13" reel.

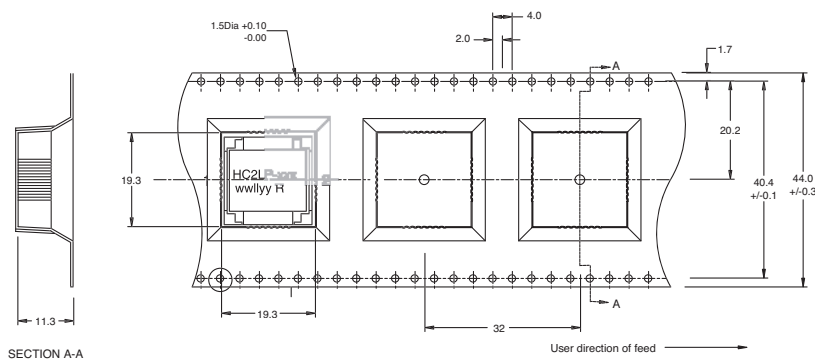

Core loss

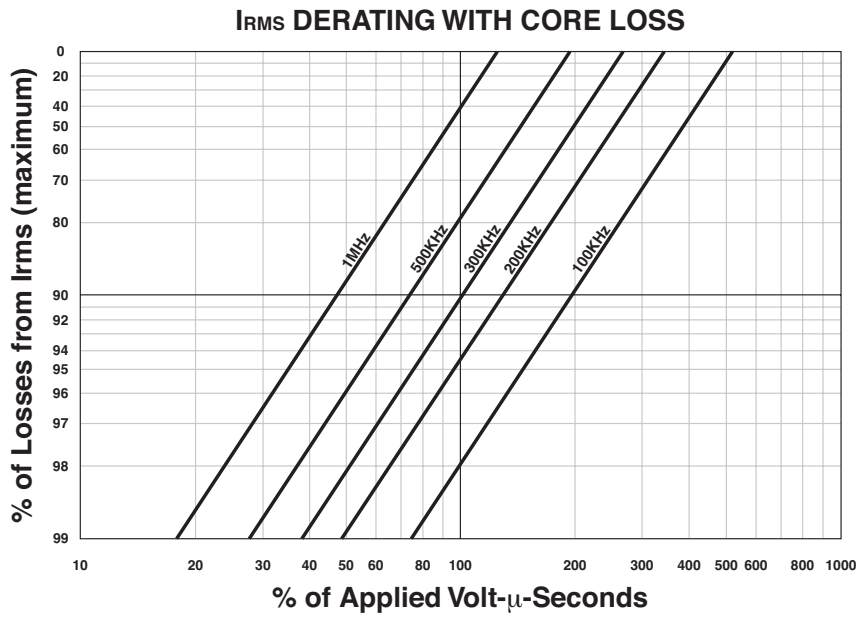

Inductance Characteristics

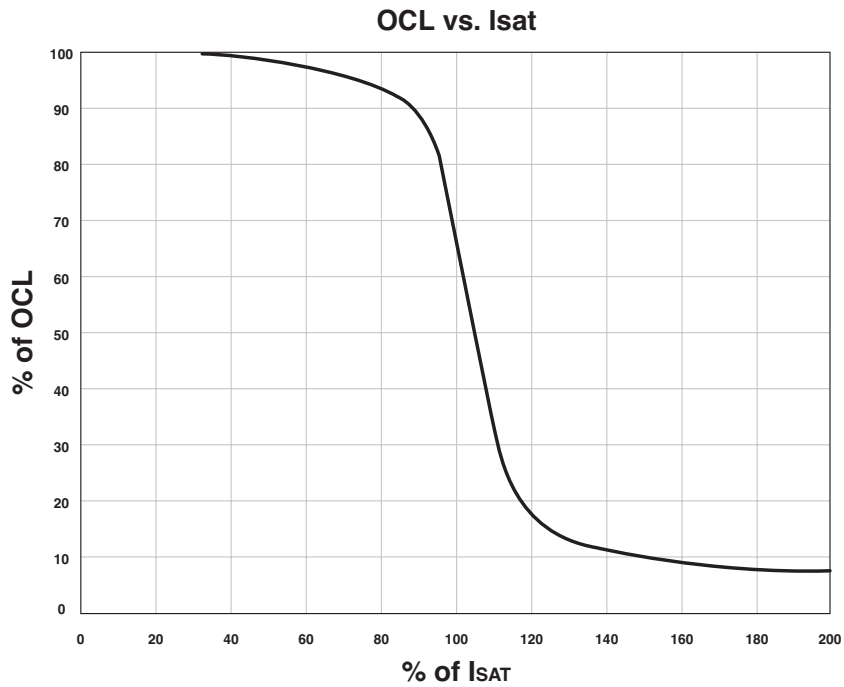

**Solder reflow profile**



**Table 1 - Standard SnPb Solder (T<sub>c</sub>)**

Package Thickness	Volume mm <sup>3</sup> <350	Volume mm <sup>3</sup> ≥350
<2.5mm)	235°C	220°C
≥2.5mm	220°C	220°C

**Table 2 - Lead (Pb) Free Solder (T<sub>c</sub>)**

Package Thickness	Volume mm <sup>3</sup> <350	Volume mm <sup>3</sup> 350 - 2000	Volume mm <sup>3</sup> >2000
<1.6mm	260°C	260°C	260°C
1.6 - 2.5mm	260°C	250°C	245°C
>2.5mm	250°C	245°C	245°C

**Reference JDEC J-STD-020D**

Profile Feature	Standard SnPb Solder	Lead (Pb) Free Solder
Preheat and Soak		
• Temperature min. (T <sub>smin</sub> )	100°C	150°C
• Temperature max. (T <sub>smax</sub> )	150°C	200°C
• Time (T <sub>smin</sub> to T <sub>smax</sub> ) (t <sub>s</sub> )	60-120 Seconds	60-120 Seconds
Average ramp up rate T <sub>smax</sub> to T <sub>p</sub>	3°C/ Second Max.	3°C/ Second Max.
Liquidous temperature (T <sub>L</sub> )	183°C	217°C
Time at liquidous (t <sub>L</sub> )	60-150 Seconds	60-150 Seconds
Peak package body temperature (T <sub>p</sub> )*	Table 1	Table 2
Time (t <sub>p</sub> )** within 5 °C of the specified classification temperature (T <sub>c</sub> )	20 Seconds**	30 Seconds**
Average ramp-down rate (T <sub>p</sub> to T <sub>smax</sub> )	6°C/ Second Max.	6°C/ Second Max.
Time 25°C to Peak Temperature	6 Minutes Max.	8 Minutes Max.

\* Tolerance for peak profile temperature (T<sub>p</sub>) is defined as a supplier minimum and a user maximum.

\*\* Tolerance for time at peak profile temperature (t<sub>p</sub>) is defined as a supplier minimum and a user maximum.

Life Support Policy: Eaton does not authorize the use of any of its products for use in life support devices or systems without the express written approval of an officer of the Company. Life support systems are devices which support or sustain life, and whose failure to perform, when properly used in accordance with instructions for use provided in the labeling, can be reasonably expected to result in significant injury to the user.

Eaton reserves the right, without notice, to change design or construction of any products and to discontinue or limit distribution of any products. Eaton also reserves the right to change or update, without notice, any technical information contained in this bulletin.

**Eaton**  
**Electronics Division**  
1000 Eaton Boulevard  
Cleveland, OH 44122  
United States  
www.eaton.com/elx

© 2015 Eaton  
All Rights Reserved  
Printed in USA  
Publication No. 4114  
October 2015



Eaton is a registered trademark.

All other trademarks are property of their respective owners.