

Type N Bulkhead Jack Crimp Style for RG-58, 142, 213, 214 and LMR-400 Flexible Cable

1. Identify connector parts. (6 piece parts)
2. Strip cable to dimensions shown. Do not nick center conductor. A wire stripper of correct size is recommended for this step. Tin center conductor if contact will be solder attached. Do not tin center conductor if contact will be crimp attached. Slide crimp sleeve onto jacket of cable.
3. Assemble jack contact onto cable as shown. Jack contact should butt against cable dielectric during attachment. Solder Attachment: Solder jack contact to center conductor through solder hole using .020 (.051) diameter flux core solder wire. Use a minimum amount of solder for a good joint. Crimp Attachment: Crimp jack contact to center conductor using Johnson ergonomic hand crimp frame 140-0000-967 with recommended hex size die set. Crimp location should be on end of jack contact next to cable dielectric. Crimp attachment to solid center conductor cables is not recommended.
4. Flare braid and slide bulkhead jack connector assembly over jack contact and under braid. Seat bulkhead jack connector assembly firmly onto contact. Arrange braid uniformly around crimp stem. Slide crimp sleeve forward and crimp using Johnson ergonomic hand crimp frame 140-0000-967 with recommended hex size die set. Maintain forward pressure on cable while crimping.

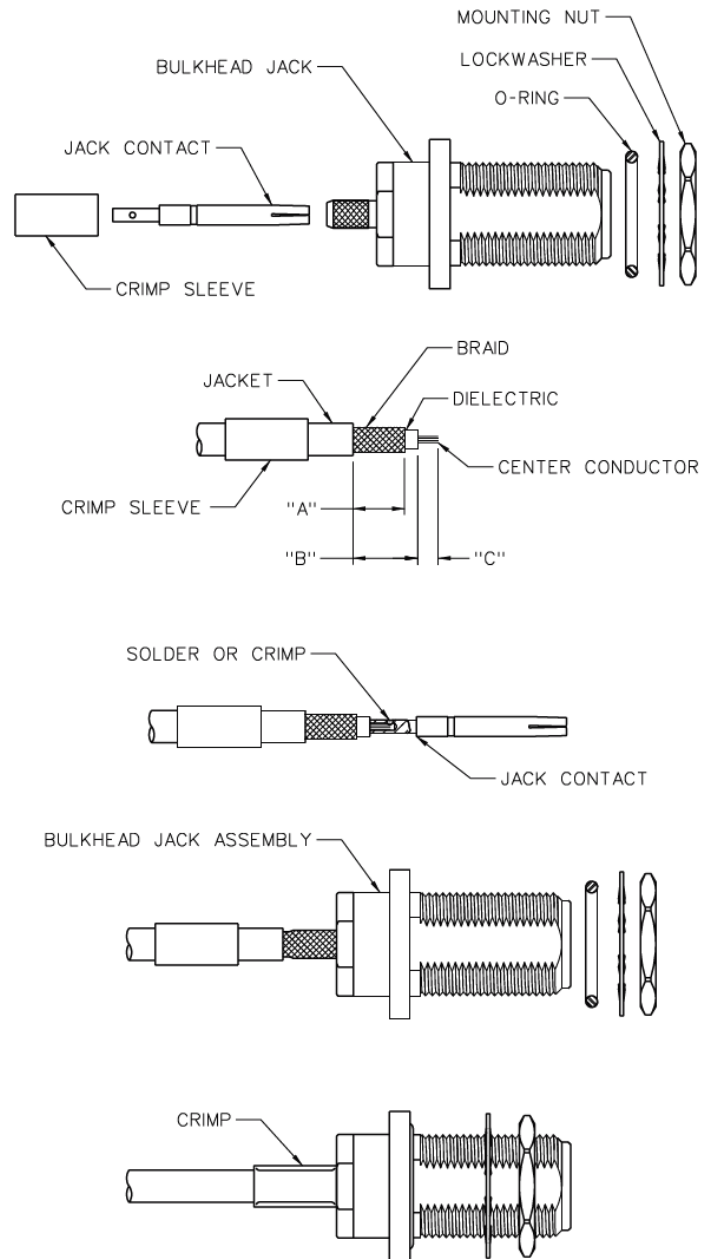

Cable Group	Part No.	"A"	"B"	Crimp Sleeve "C"	Contact Hex Size	Hex Size
RG-58/U, 141, 303	138-4307-407	.310 (7.87)	.389 (9.88)	.135 (3.43)	.213 (5.41)	.068 (1.73)
RG-55/U, 142, 223, 400	138-4308-407	.310 (7.87)	.389 (9.88)	.135 (3.43)	.213 (5.41)	.068 (1.73)
RG-8, 213	138-4316-407	.385 (9.78)	.400 (10.16)	.165 (4.19)	.429 (10.90)	.111 (2.82)
RG-9, 214	138-4318-407	.385 (9.78)	.400 (10.16)	.165 (4.19)	.429 (10.90)	.111 (2.82)

Assembly

Tool	138-4307/4308-407	138-4316/4318/4349-407
Crimp Frame	140-0000-967	140-0000-967
Die Set	140-0000-990	140-0000-991

Cinch Connectivity Solutions Waseca
299 Johnson Avenue SW, Suite 100
Waseca, MN 56093 USA

+1 507.833.8822
inquiry@cinch.com
cinch.com