

Apr.1.2017 Copyright 2017 HIROSE ELECTRIC CO., LTD. All Rights Reserved.

COUNT	DESCRIPTION OF REVISIONS	BY	CHKD	DATE	COUNT	DESCRIPTION OF REVISIONS	BY	CHKD	DATE
△				..	△				..
△				..	△				..
△				..	△				..

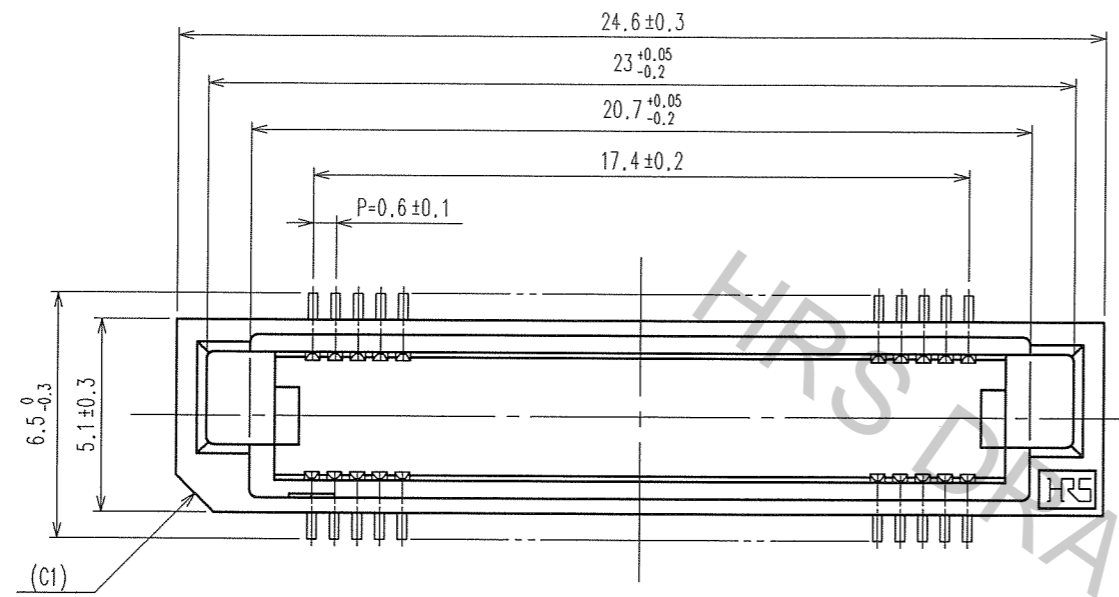

RECOMMENDED LAND PATTERN DIMENSION OF PCB
(MOUNTING SIDE) (2:1)

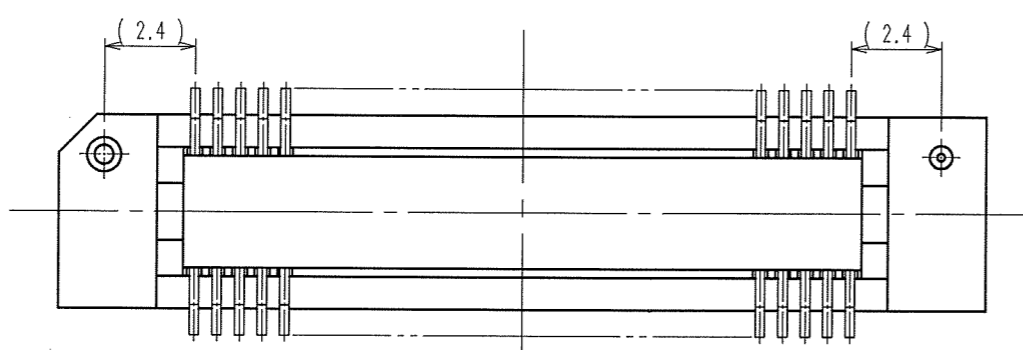
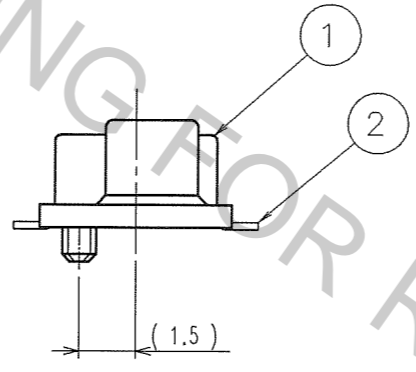
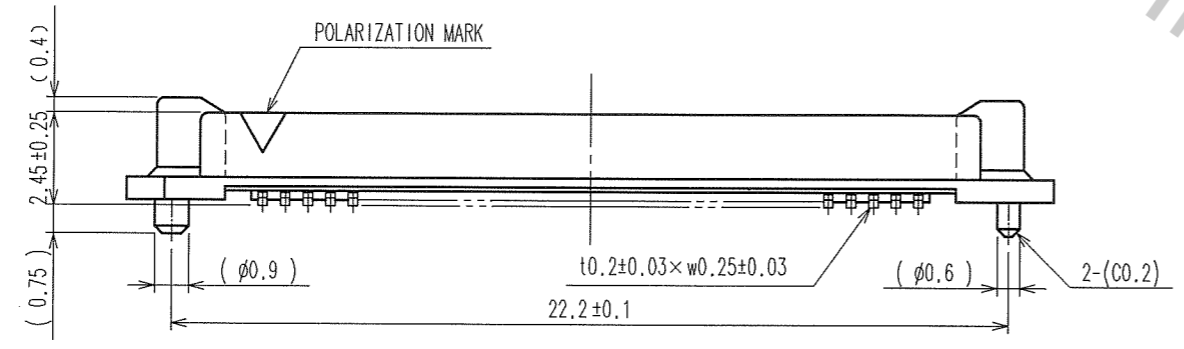
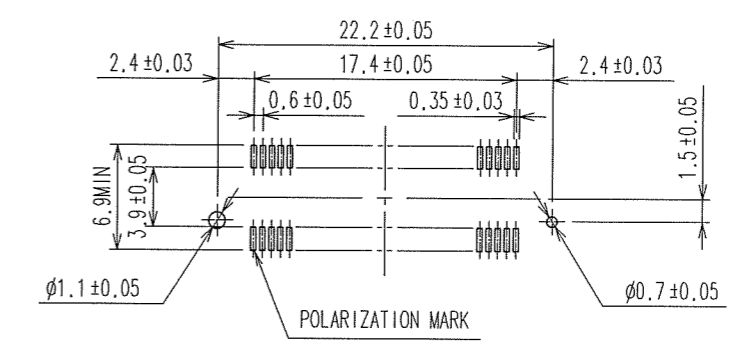

- NOTE 1. LEAD CO-PLANARITY SHALL BE 0.1mm.
 2. FOR MODIFICATION, ETC., PREVENTIVE HOLE FOR SINK MARK MAY BE ADDED ACCORDING TO CIRCUMSTANCES.
 3. THE DIMENSIONS IN PARENTHESES ARE FOR REFERENCE.

TO
PCK

1	Polyphenylene Sulfide	LIGHT BROWN	UL94V-0	2	PHOSPHOR BRONZE	CONTACT AREA:GOLD 0.1μm min. MOUNTING AREA:GOLD PLATING FLASH UNDER PLATING : NICKEL 0.5μm min.				
NO.	MATERIAL	FINISH, REMARKS		NO.	MATERIAL	FINISH, REMARKS				
CODE NO. (OLD) CL				DRAWN	DESIGNED	CHECKED	APPROVED	RELEASED		
				T. NODA '05.06.27	H. Sai '05.06.29	H. Ogawa '05.06.30	H. Okawa '05.06.30	..		
DRAWING NO. EDC3-150564-25				PART NO. FX8-60P-SV(71)						
SCALE 5 : 1				UNITS mm				CODE NO. CL578-0001-6-71		1/1
HRS HIROSE ELECTRIC CO., LTD										

