

Features:

- Highly Integrated Solution that includes:
Optimized Flyback Boost Converter Controller, IGBT Driver, 100mA LED Torch Driver, and Transformer Drive Transistor
- Small Size (3mm x 5mm DFN-16)
- High Efficiency
- 3.0 to 5.5 Volt Battery Operation
- 1.65 to 5.5 Volt Digital Interface Operation
- Low Shut Down Current: 0.1 μ A
- SPI and I²C Bus Compatibility
- Programmable Average Battery Current: (50mA – 220mA)
- Programmable Output Voltage: (300V - 330V)

Applications:

- Camera Cell Phones, Digital Still Cameras, and Optical Film Cameras

Ordering Information

Part No.	Description	Qty
MX881R	3mm X 5mm DFN-16	73
MX881RTR	DFN-16 Tape & Reel	2000

General Description

The MX881 offers a highly integrated Xenon Flash controller, providing an ideal solution for small form factor flash and torch lighting applications. The MX881 integrates a user programmable Controller, IGBT Driver, 100mA LED Torch Driver, and Transformer Drive Transistor to significantly reduce component count, solution size, and design complexity.

The Boost Control Logic manages the peak primary current and off time to optimize charge time and control average battery current.

The Charge Cycle Control starts the charge cycle on a low to high transition of the CHARGE input. Then detects when the output voltage has reached the desired voltage and stops the Boost Control Logic, while asserting the DONE output signal.

The SPI/I²C serial interface adds the flexibility of 6 programmable average battery currents and 4 programmable high voltage output levels for the flash function.

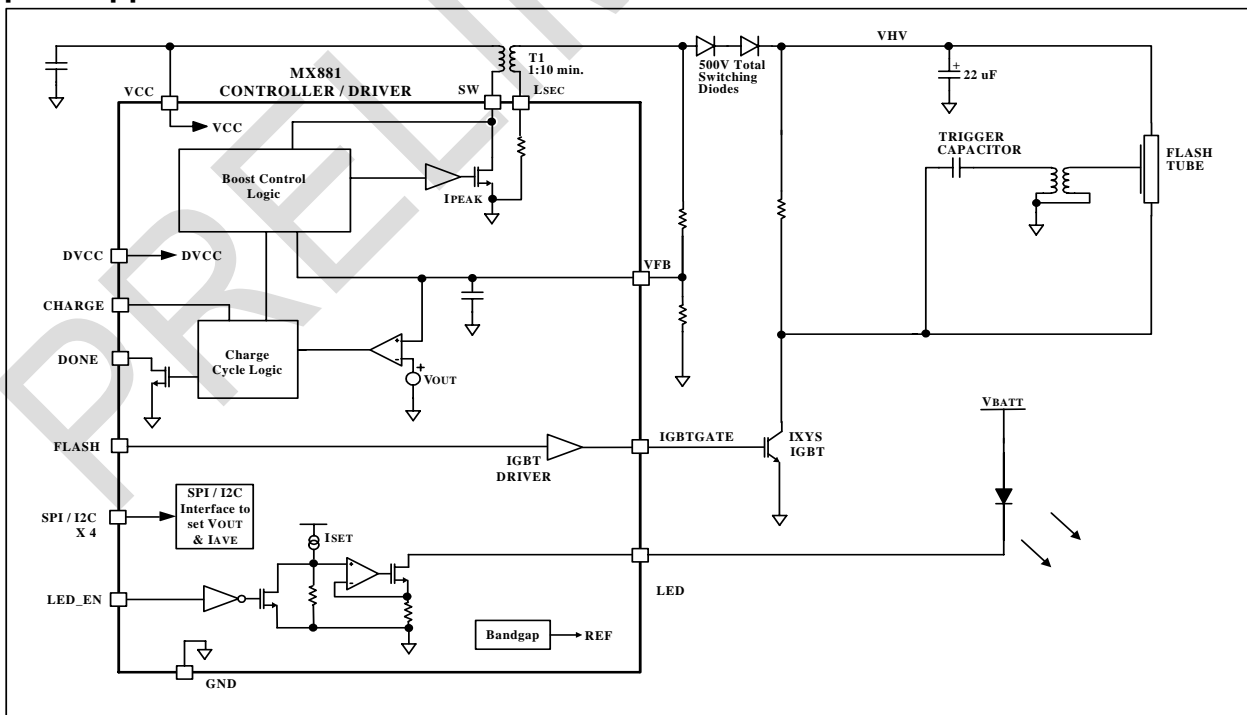
Typical Application

Boost Switch: When turned on, current flows in the primary of the flyback transformer. The energy stored in the transformer is transferred to the secondary as high voltage when the boost switch is turned off.

IGBT Driver: Switches the VCC supply to the IGBT gate when the FLASH signal is brought high. If FLASH is low, the IGBT gate is driven to ground.

LED Driver: When LED_EN is high, the LED pin will sink 100mA to GND. If LED_EN is low, the LED pin is high impedance.

Pin Description

Pin No.	Pin Name	Description
11	VCC	Supply voltage from battery, (3.0V – 5.5V). Must be connected to VDVCC.
7	DVCC	Digital supply voltage for I/O logic (1.65V-5.5V)
15	CHARGE	Low level stops the charging cycle and puts the device into power down mode. Charge remains on the high voltage capacitor. A high level starts a charging cycle. Charging continues until either the correct voltage is reached or CHARGE is brought low.
6	DONE	Open drain output that transitions high when the capacitor reaches the desired voltage. This output is normally high except when charging so that standby current is minimized. (Pull-up resistor not sourcing current).
12	VFB	Feedback voltage input from voltage divider that determines when the output has reached the desired voltage.
14	FLASH	A high level will cause the IGBT to turn on firing the flash. A low level will turn the IGBT off. FLASH can be brought low to shorten the flash pulse for red-eye reduction.
16	ISEL	High level enables the I ² C interface, low level enables SPI interface.
1	SCEn	Serial port chip enable. A low on this pin enables the SPI interface to receive data. If SCEn is asserted low while in the I2C mode, the serial interface and control register are reset.
4	SCLK	Clock input for SPI and I ² C interface.
2	SDATA	Data input and output for SPI interface. Data input and acknowledge/data output for I ² C interface. This output is open drain for I ² C output data.
3	SW	Connection to internal power transistor that drives the negative terminal of the transformer primary coil.
13	LSEC	Connection to negative terminal of the transformer secondary. This input is grounded internally through a low impedance used to sense the secondary transformer current.
9	IGBTGATE	IGBT Gate driver output.
5	LED_EN	A high level will cause the 100mA LED current regulator to turn on. $V_F = V_{BATT}$
10	LED	100mA LED current regulator. Connect the cathode of the torch LED to this pin. $V_F = V_{BATT}$
Exposed Pad	GND	Ground Terminal.
8	N/C	No Connect. Do not connect to any signal, ground or power source.

Absolute Maximum Ratings

Symbol	Parameter	Rating	Unit
VCC, DVCC	DC Supply Voltage	0.3 to 7.0	V
V _{IN}	DC Input Voltage	-0.3 to VCC+0.3	V
V _{SW}	Voltage On SW pad	-0.3 to 55	V
T _{STG}	Storage Temperature	-40 to +150	°C

Stresses beyond those listed under "absolute maximum ratings" may cause permanent damage to the device. These are stress ratings only and functional operation of the device at these or any other conditions beyond those indicated under "recommended operating conditions" is not implied. Exposure to absolute-maximum-rated conditions for extended periods may affect device reliability.

Recommended Operating Conditions

Symbol	Parameter	Rating	Unit
VCC	Analog and Digital Supply Voltage	3 to 5.5	V
DVCC	Digital I/O Supply Voltage	1.65 to 5.5	V
V _{IN}	DC Input Voltage	0 to DVCC	V
V _{SW}	Voltage On SW pad	0 to 40	V
T _J	Junction Temperature	-20 to +115	°C

DC Characteristics

Junction temperature range -20 to +115°C

Symbol	Parameter	Condition	Min	Typ	Max	Unit
AVCC	Supply Voltage – Analog and voltage doubler		3	3.6	5.5	V
DVCC	Supply Voltage – Digital I/O		1.65	3.3	5.5	V
I _{CC}	Supply Current (When Charging)				4	mA
I _{STANDBY}	Supply Current (Not Charging)	@ 25° C		0.1		μA
I _{SW LEAK}	SW pin Leakage Current	@ 25° C V _{sw} = 40V		30		nA
V _{T+}	Schmitt trigger, positive-going threshold (All digital inputs)	1.65V < DVCC < 2.4V			1.3	V
V _{T-}	Schmitt trigger, negative-going threshold (All digital inputs)	1.65V < DVCC < 2.4V	0.4			V
V _{hys}	Hysteresis, Schmitt trigger	1.65V < DVCC < 2.4V	0.15			V
V _{T+}	Schmitt trigger, positive-going threshold (All digital inputs)	2.4V < DVCC < 3.6V			1.6	V
V _{T-}	Schmitt trigger, negative-going threshold (All digital inputs)	2.4V < DVCC < 3.6V	0.65			V
V _{hys}	Hysteresis, Schmitt trigger	2.4V < DVCC < 3.6V	0.16			V
V _{T+}	Schmitt trigger, positive-going threshold (All digital inputs)	3.6 < DVCC < 5.5V			2.1	V
V _{T-}	Schmitt trigger, negative-going threshold (All digital inputs)	3.6V < DVCC < 5.5V	0.9			V
V _{hys}	Hysteresis, Schmitt trigger	3.6V < DVCC < 5.5V	0.17			V
I _{IN}	Input Current	V _{IN} = DVCC or GND	-10		10	μA
V _{OL}	Output Low Voltage	2K to DVCC			0.15	V
V _{OH}	Output High Voltage	2K to Ground	DVCC-0.3			V
R _{SW}	SW Switch on resistance	DVCC = 3.0V	.15	.25	.50	Ω
R _{SW}	SW Switch on resistance	DVCC=3.0V, @ 25°C	.19	.25	.32	
I _{LED}	LED drive current	V _{LED} > 0.5V	85	100	115	mA
I _{PEAK}	Primary Peak Current			.7		A
V _{TRIP}	Output Voltage Trip Point	OVS = 11	1.20	1.23	1.26	V
		OVS = 10	1.16	1.19	1.22	V
		OVS = 01	1.12	1.15	1.18	V
		OVS = 00	1.10	1.12	1.14	V

AC Characteristics

Junction temperature range 0 to + 115°C

Symbol	Parameter	Condition	Min	Typ	Max	Unit
T _{START}	CHARGE High to Beginning of Charge Cycle			110		μS
T _{END}	CHARGE Low to End of Charge Cycle			100		nS
T _{IGBT-ON}	FLASH High to IGBTGATE High	CL = 6.8nF, 10% to 90%		100		nS
T _{IGBT-OFF}	FLASH Low to IGBTGATE Low	CL = 6.8nF, 90% to 10%		100		nS
T _{LED-ON}	LED_EN High to Iout > 90mA			TBD		μS
T _{LED-OFF}	LED_EN Low to Iout < 1mA			TBD		μS

Control Register

The MX881 control register is a 5 bit register that allows the user to program the maximum output voltage and the maximum average battery current during the charge cycle. Table1 shows how the bits in the control register are assigned. ABC(2:0) are used to set the average battery current and OVS(1:0) are used to set the output voltage selection reference.

Table 1 – Control Register

BIT:	D4	D3	D2	D1	D0
Control:	OVS1	OVS0	ABC2	ABC1	ABC0

Output Voltage Selection

The MX881 limits the high voltage placed on the external capacitor by comparing a divided down version of the secondary flyback voltage to an internal voltage. This internal voltage is programmable to 4 discrete values to allow the user to change the flash energy. The external voltage divider ratio needed to obtain 330V maximum output voltage should be 269 to 1. This external resistor divider network is also used to form a low pass filter with an internal capacitor so it is important that the equivalent resistance of the voltage divider network be 3K ohms. Table 2 shows the internal reference values used for possible values of the capacitor charge voltage. The default value is 11.

Table 2 - Output Voltage Selection

OVS Value (Binary)	Reference Voltage (V _{TRIP})	Capacitor Voltage
11	1.23	330
10	1.19	320
01	1.15	310
00	1.12	300

Average Battery Current

The 3 bits (ABC2 – ABC0) of the control register are used to program the maximum average battery current during a charge cycle. The MX881 does this by limiting the minimum off time during a switching cycle. The off time compensates for variation of the battery voltage so that the average current is independent of battery voltage. The default value of ABC is 101. With the default value of ABC, the average battery current control circuits are disabled for maximum efficiency, and the maximum battery current is approximately 220mA. The average current versus the output voltage is shown in Figure1.

The battery current peak value is preset internally to 0.7A. This current must be averaged by placing an external bypass capacitor from VCC to ground. A 10uF capacitor is recommended for good current smoothing and averaging.

Figure 1 - Average Battery Current

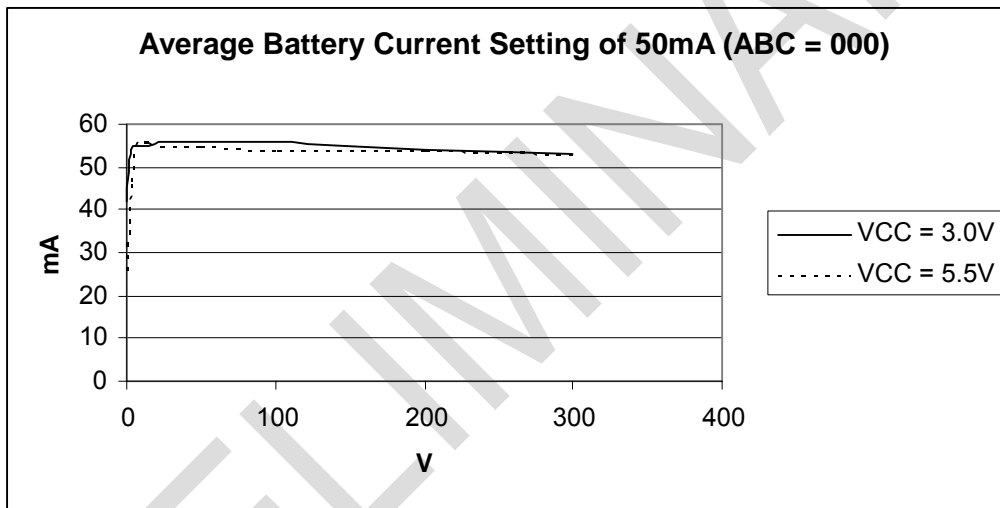

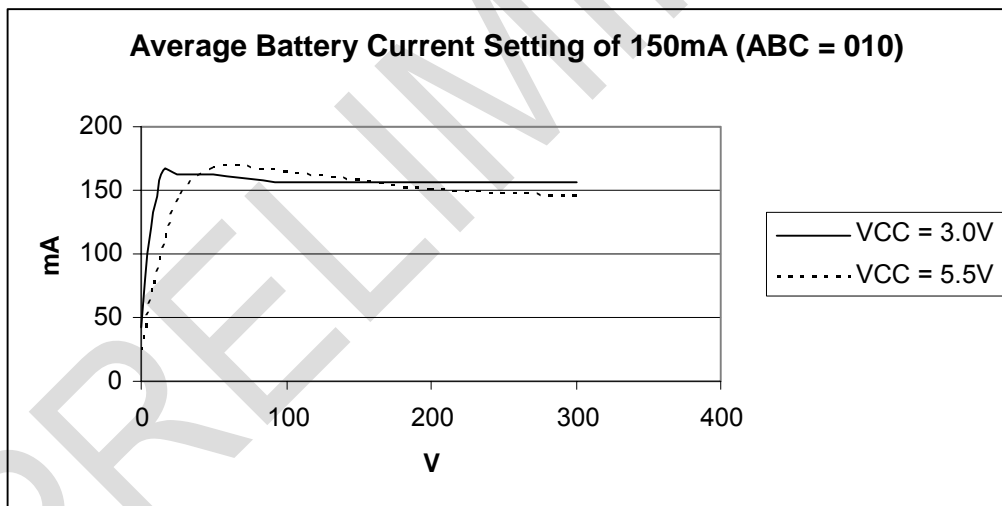
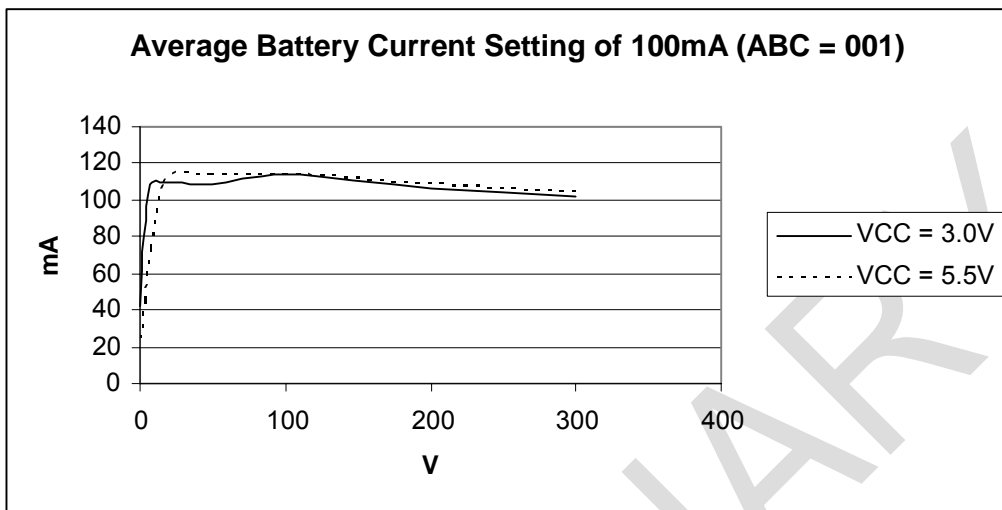

Serial Interface

The MX881 has a 4 wire serial interface that is capable of operating in two modes: I²C or SPI. Both modes transfer 8 bits of information but only 5 bits are actually used to set the internal control register.

Table 3 - Interface Modes

ISEL	Active Interface
1	Standard I ² C slave only serial interface
0	Standard 3-wire SPI

I²C Bus Interface

The I²C interface (follows the standard bus protocol and timing as defined by Philips). For complete information on this bus, refer to

www.semiconductors.philips.com

The MX881 acts as a slave device on the I²C bus and is compatible with both the HS (High Speed) Mode and Fast Mode formats. Its primary function is as a receiver, receiving data from a master device that is used to set a single 5 bit register that determines the average battery current and the output voltage. It will act as a transmitter after receiving a read command. During a read, the register data will be output onto the I²C bus. When receiving a non-broadcast message, the MX881 will respond with an acknowledge bit, in which it pulls the data bus low at the appropriate time. Data packets begin with the Master issuing a START command (S) and end with the Master issuing a STOP command (P). A Restart command is simply another START command that is issued before a STOP command. Note that with START and STOP commands that SDATA transitions while SCLK is high. Conversely, for all other bits, SDATA is only allowed to transition while SCLK is low.

Figure 2 - I²C Sequences

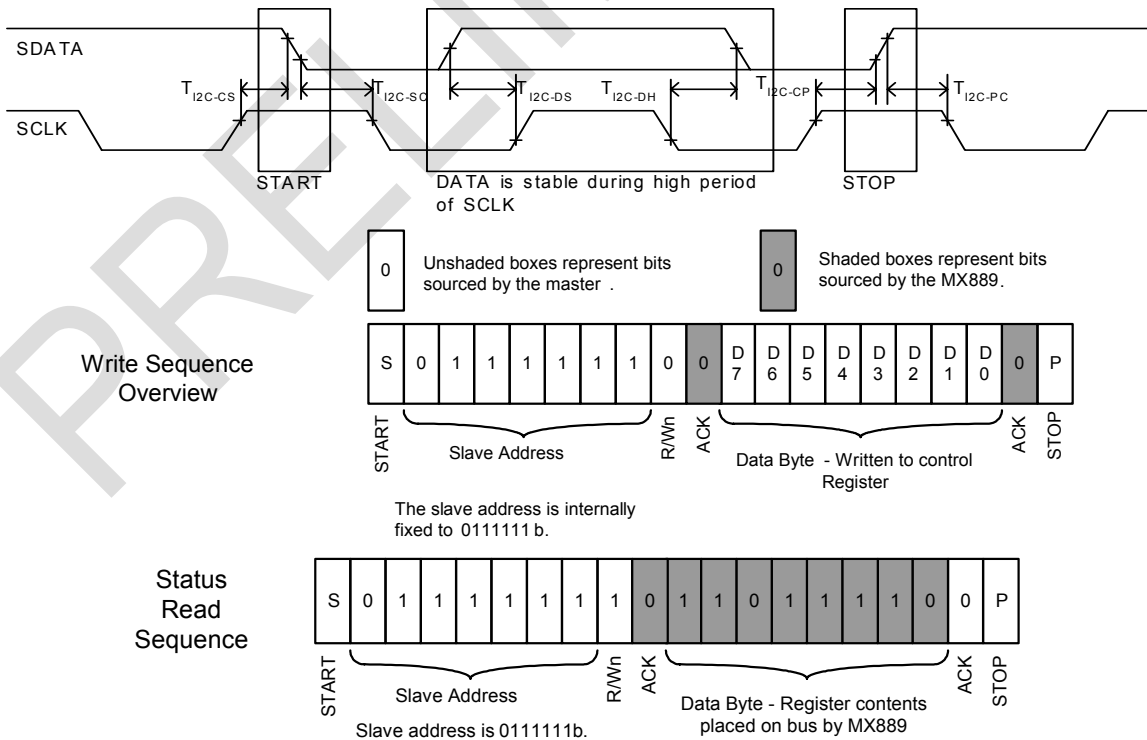

To write to the MX881 register, the master device will first issue a Start Bit. It will then transmit a 7-bit address. In the MX881, the address is internally set to 0111111b. If the address in the message corresponds to the address of the MX881, the device will issue an acknowledge. The master will send 8 bits of data. These 8 bits will be written into the control register. Another Acknowledge will follow. The write sequence is illustrated in Figure 2.

To read the control register the master issues a read command by setting the R/Wn bit. The master will then tri-state the data bus while the MX881 outputs data. See the example in Figure 2.

3-Wire SPI (Serial Peripheral Interface)

A standard 3-wire bi-directional serial interface is available (Figure 3). The interface signals are the serial clock: SCLK, the serial data line: SDATA, and the serial chip enable: SCEn. SDATA is bidirectional.

In write mode, the microcontroller is writing to the MX881 control register. Each packet sent contains an 8-bit command followed by 8 bits of data to be written into the register.

When SCEn goes low, the rising edge of SCLK clocks in 8 bits, MSB first. At the end of the first transmission byte, the MX881 determines whether the first byte is a recognized command. The MX881 only recognizes one write command “00011110”. If the command is recognized, the next byte clocked into the MX881 will be written into the control register. This sequence is illustrated in Figure 3.

In read mode, a command is received which tells the MX881 to output the control register contents. The MX881 only recognizes one read command: “01011110”. If the correct command is recognized, the MX881 will output 8 bits of data beginning on the first falling edge of SCLK after the rising edge of SCLK in which the last transmission bit was clocked in. In this manner, the first control register bit will be available to the microcontroller on the next rising edge of SCLK. SCEn must remain low while the MX881 is outputting data, going high after the MX881 has output the last bit. While the device is outputting data, the microcontroller must stop driving the SDATA line so that the MX881 can drive the data onto this bus. This sequence is also illustrated in Figure 3.

Table 4 - Serial Interface Timing

Symbol	Parameter	Condition	Min	Max	Units
T _{CYCS}	Cycle Time		250		nS
T _{HI} , T _{LO}	Pulse Width		50		nS
T _{DS}	Data Setup Time		50		nS
T _{DH}	Data Hold Time		30		nS
T _{SS}	SCEn Setup Time, Write		30		nS
T _{SH}	SCEn Hold Time, Write		30		nS
T _{ACCS}	Read Access Time	C _L = 100pF		30	nS
T _{OHS}	Read Output Disable Time	C _L = 100pF		30	nS
T _{I2C CS}	I ² C Clock High to Start Bit		50		nS
T _{I2C SC}	I ² C Start Bit to Clock Low		50		nS
T _{I2C DS}	I ² C Data Valid to Clock High		50		nS
T _{I2C DH}	I ² C Clock Low to Data Change		30		nS
T _{I2C CP}	I ² C Clock High to Stop Bit		50		nS
T _{I2C PC}	I ² C Stop Bit to Clock Low		50		nS

Figure 3 – 3-WIRE SPI

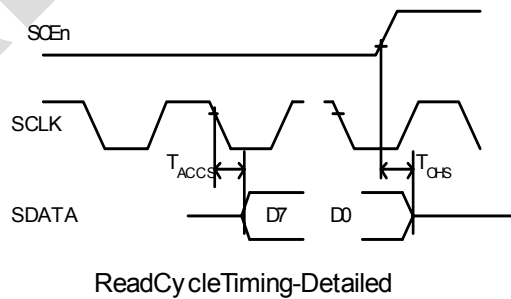
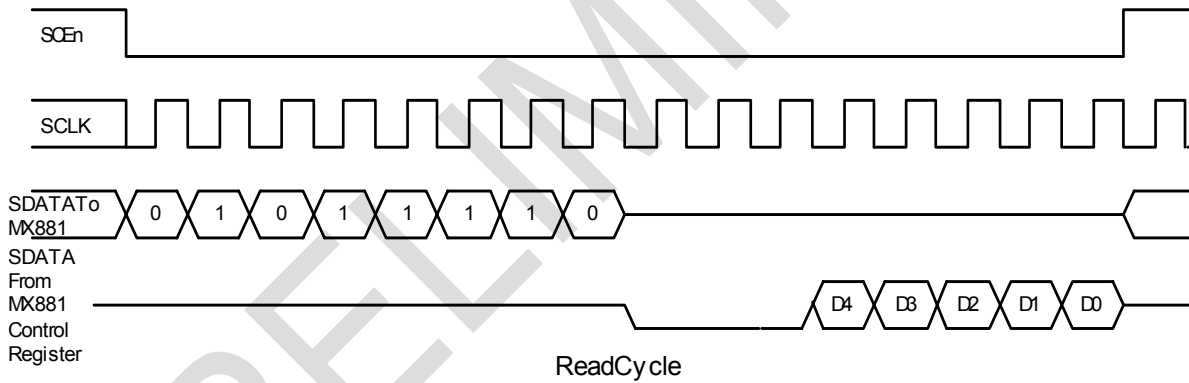
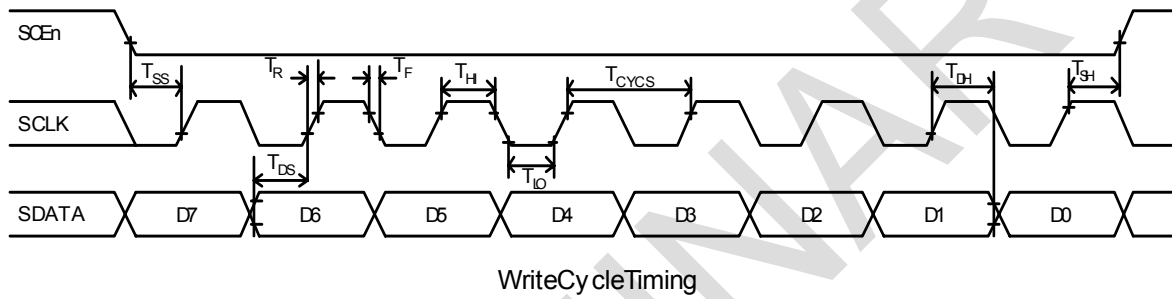
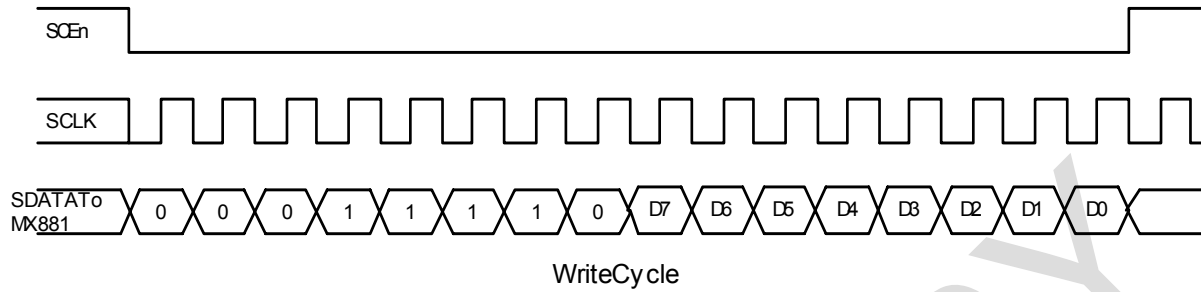

Layout Notes

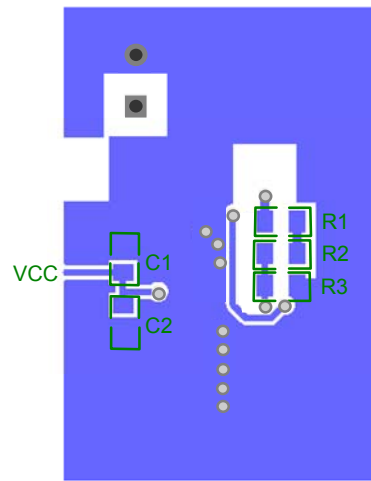
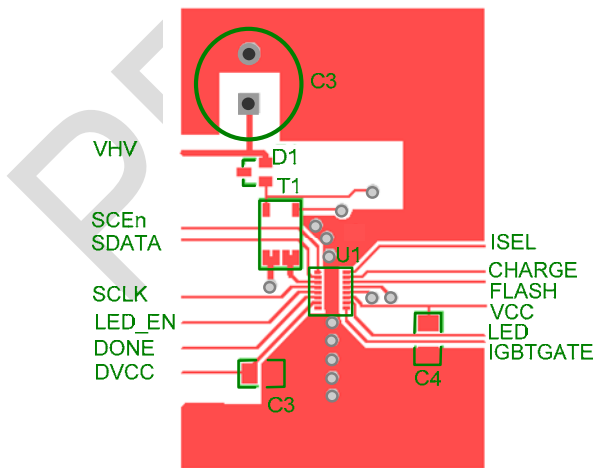
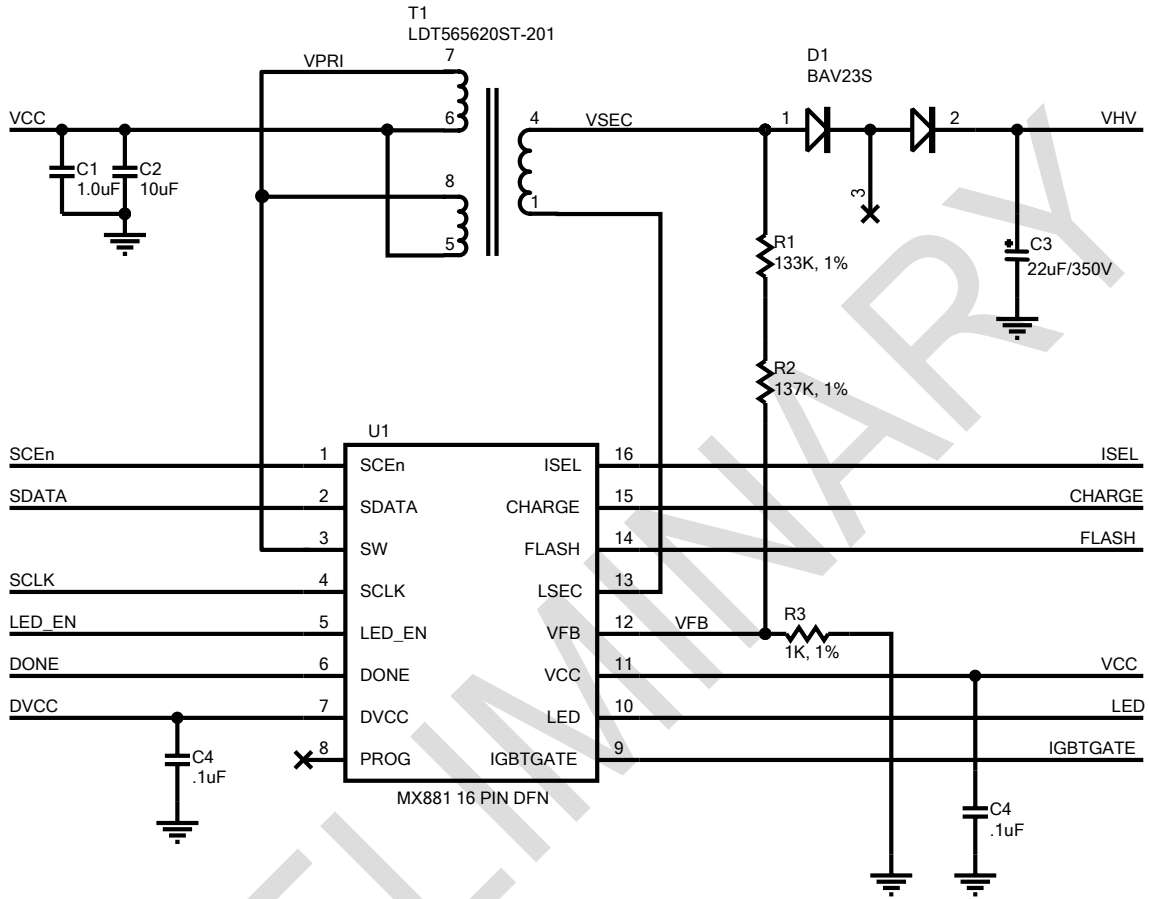

Layout Notes:

- Parasitic capacitance on node VSEC or VPRI will cause loss of efficiency. Keep wires on this node as short as possible.
- Parasitic inductance on the transformer connections can cause overshoot during switching that could damage the part. Keep connections from the capacitors and MX881 to the transformer short.
- Also keep the connection from pin 2 of D1 to C3 as short as possible.
- The VFB node is sensitive to coupling from T1 and the VSEC node. The VSEC node ramps to over 300 volts in just a few nano-seconds. Keep R1, R2, and R3 as far from T1 as possible. If possible, shield resistors by placing on the other side of the board from T1.
- VCC should be well bypassed to average charge current to the battery and reduce noise to analog circuits within MX881.
- VFB is a very fast and short pulse. Keep VFB connection to R7 short to minimize capacitance on this node. If VFB has too much capacitance, the feedback voltage may be filtered so that the output voltage does not stop at 330V but continues to a much higher voltage.
- A good ground plane is extremely important. Large pulse currents of 0.7 amps will be flowing in the ground. The large bottom pad of the MX881 is the only ground pad and requires a low impedance return to C1, C2, and R7.
- The ground plane must have adequate clearance from high voltage nodes VHV and VSEC to avoid arcing. Also, the node connecting R1 to R2 will be at approximately 170V.
- R1 and R2 must be at least 1206 size surface mount to withstand 200V each.

Transformer

For 330V charger, the transformer should have a turns ratio of approximately 10 to insure that the fly-back voltage on the primary side of the transformer does not damage the power switch internal to the MX881. The fly-back voltage should be equal to the output voltage divided by the turns ratio plus the VCC supply voltage. The fly-back voltage will be greater than this due to the energy stored in the transformer leakage inductance. The actual voltage will depend on the transformer leakage inductance and the parasitic capacitance of the circuits and layout.

The MX881 is designed to work with a transformer having a primary inductance of approximately 10 μ H. Larger values are acceptable as long as leakage inductance is small. Smaller primary inductance values may cause feedback pulses that are too short and lead to higher than expected output voltage.

IXYS Corporation makes no representations or warranties with respect to the accuracy or completeness of the contents of this publication and reserves the right to make changes to specifications and product descriptions at any time without notice. Neither circuit patent licenses nor indemnity are expressed or implied. Except as set forth in IXYS' Standard Terms and Conditions of Sale, IXYS Corporation assumes no liability whatsoever, and disclaims any expressed or implied warranty, relating to its products including, but not limited to, the implied warranty of merchantability, fitness for a particular purpose, or infringement of any intellectual property right

IXYS Corporation

3540 Bassett Street
Santa Clara, CA 925054
Tel: 408-982-0700
Fax: 408-496-0670
e-mail:sales@ixys.net

Micronix**An IXYS Company**

145 Columbia
Aliso Viejo, CA 92656-1490
Tel: 1-949-831-4622
Fax: 1-949-831-4628

SALES OFFICES AMERICAS**Eastern Region**

[Eastern North America, Mexico, South America]
IXYS Corporation
Beverly, MA
Tel: 508-528-6883
Fax: 508-528-4562
wgh@ixys.net

Central Region

[Central North America]
IXYS Corporation
Greensburg, PA
Tel: 724-836-8530
Fax: 724-836-8540
neil.lejeune@westcode.com

Western Region

[Western North America]
IXYS Corporation
Solana Beach, CA
Tel: 858-792-1101
slodor@ix.netcom.com

SALES OFFICES EUROPE**European Headquarters**

IXYS Semiconductor GMBH
Edisonstrasse 15
D- 68623 Lampertheim
Germany
Tel: 49-6206-503203
Fax: 49-6206-503286
marcom@ixys.de

United Kingdom

IXYS Semiconductor Limited
Langley Park Way
Langley Park
Chippenham
Wiltshire SN 15 1GE - England
Tel: 44 1249 444524
Fax: 44 1249 659448
sales@ixys.co.uk

SALES OFFICES ASIA / PACIFIC**Asian Headquarters**

IXYS
Room 1016, Chia-Hsin, Bldg II,
10F, No. 96, Sec. 2
Chung Shan North Road
Taipei, Taiwan R.O.C.
Tel: 886-2-2523-6368
Fax: 886-2-2523-6368
bradley.green@ixys.co.uk
Jhong@clare.com

Check the IXYS Website for the local sales office nearest you. (www.ixys.com)

<http://www.claremicronix.com>

IXYS cannot assume responsibility for use of any circuitry other than circuitry entirely embodied in this IXYS product. No circuit patent licenses nor indemnity are expressed or implied. IXYS reserves the right to change the specification and circuitry, without notice at any time. The products described in this document are not intended for use in medical implantation or other direct life support applications where malfunction may result in direct physical harm, injury or death to a person.

Specification: MX881
©Copyright 2007, IXYS Corporation
All rights reserved. Printed in USA.