

REV	DATE	DESCRIPTION	BY	APPD
0	12-13-89	RELEASED HAS 89-4829-38	JMB	
A	03-22-90	REVISED PER ECN DF-2957		
B	05-08-90	REVISED PER ECN DF-3332		
C	08-21-90	REVISED PER ECN DF-3520		

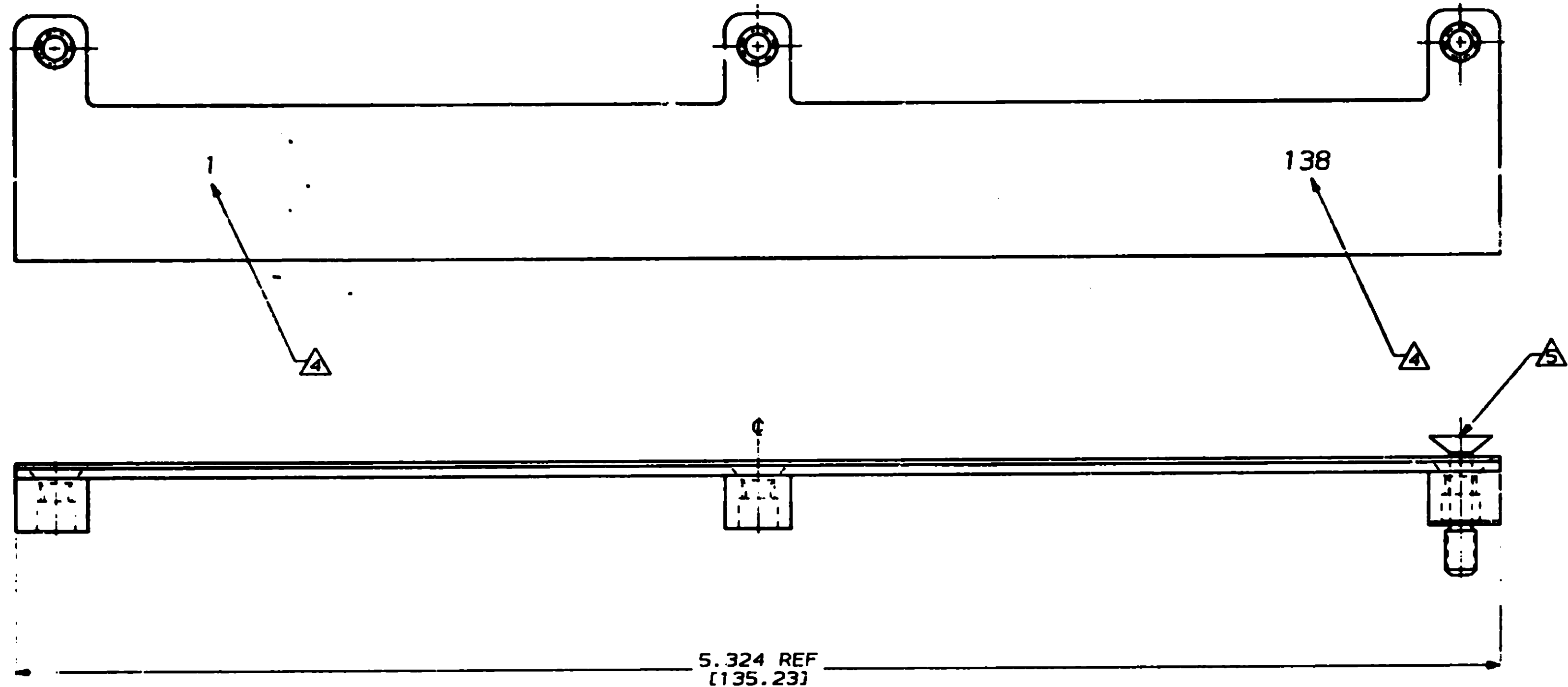

- △ MATERIAL: ALUMINUM, ASTM B 221-ALLOY 5061-T6.
- △ FINISH: CHROMATE CONVERSION PER MIL-C-5541, CLASS 3.
- △ INK STAMP AMP, AMP P/N, DATE CODE AND FSCM NO. IN THIS AREA PER MIL-STD-1285 AND MIL-STD-202, METHOD 215.
- △ INK STAMP NUMBE 5 "1" AND "138" IN AREA SHOWN PER MIL-STD-1285 AND MIL-STD-202, METHOD 215.
- △ CAPTIVE SCREW MS 24693-C7 MODIFIED, 3 REQ'D.

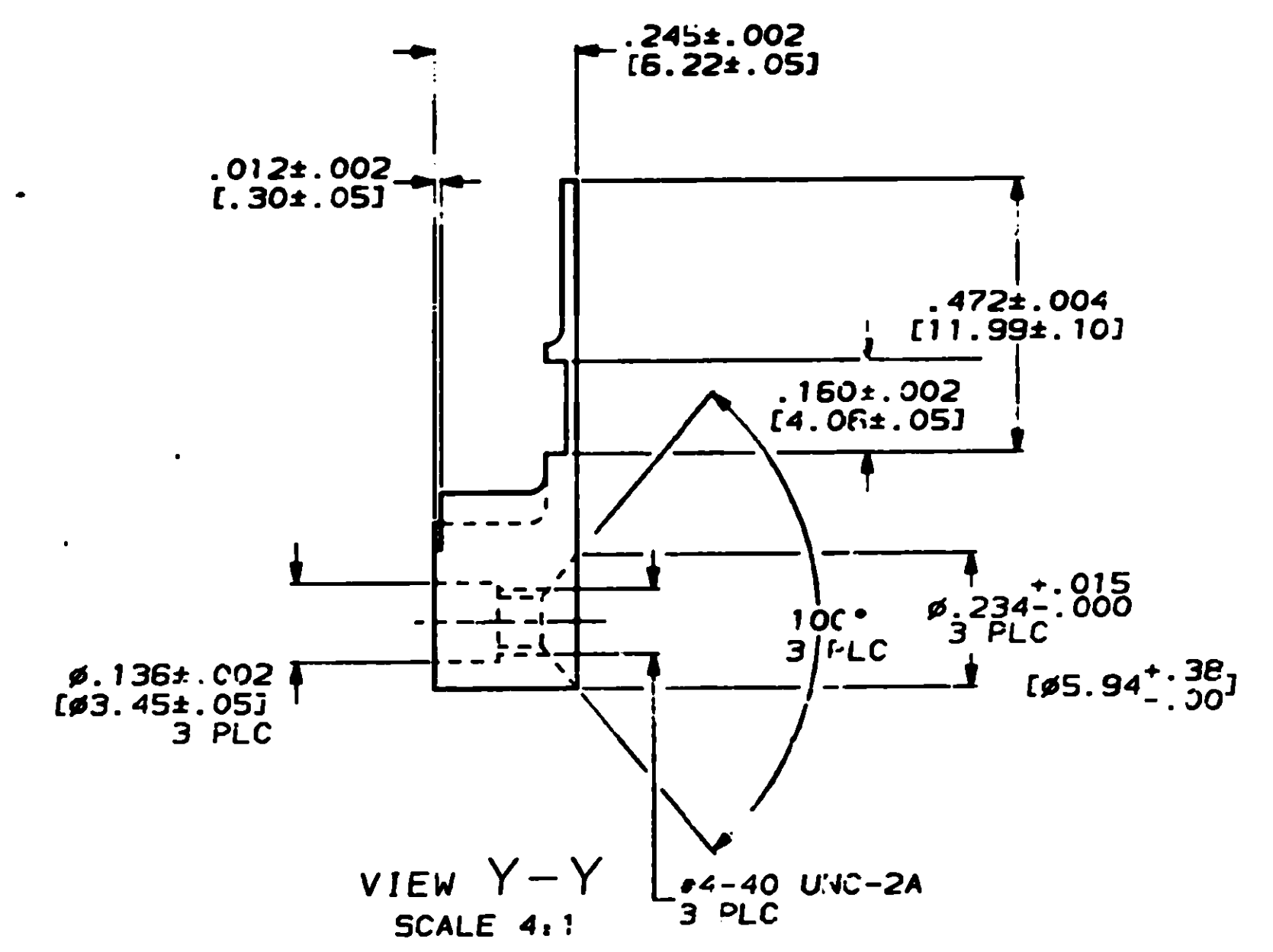
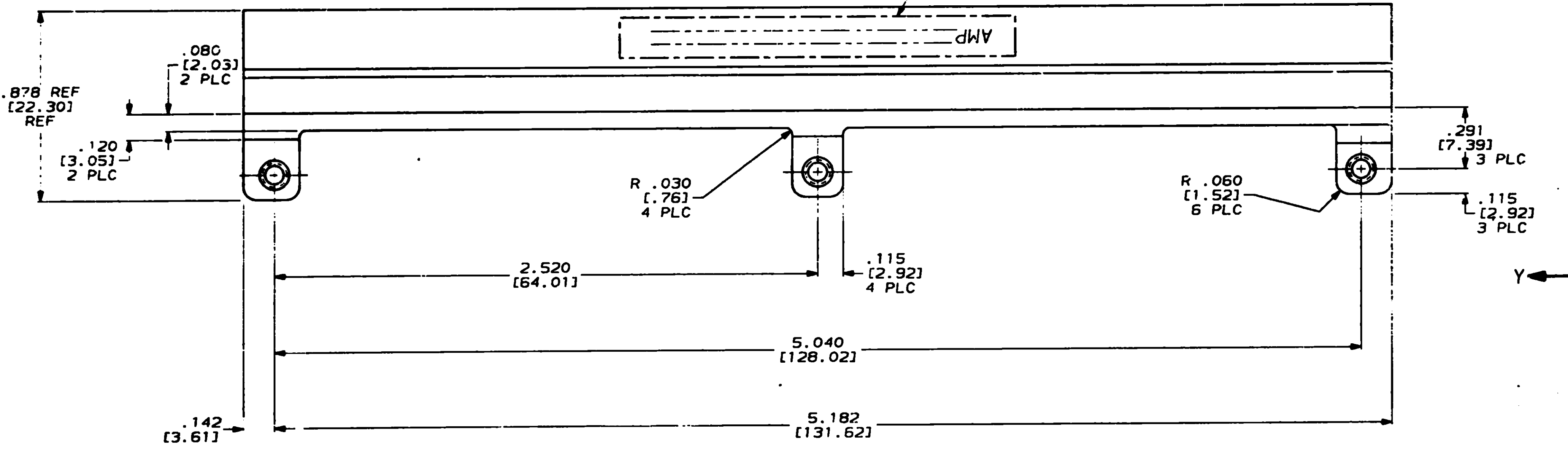
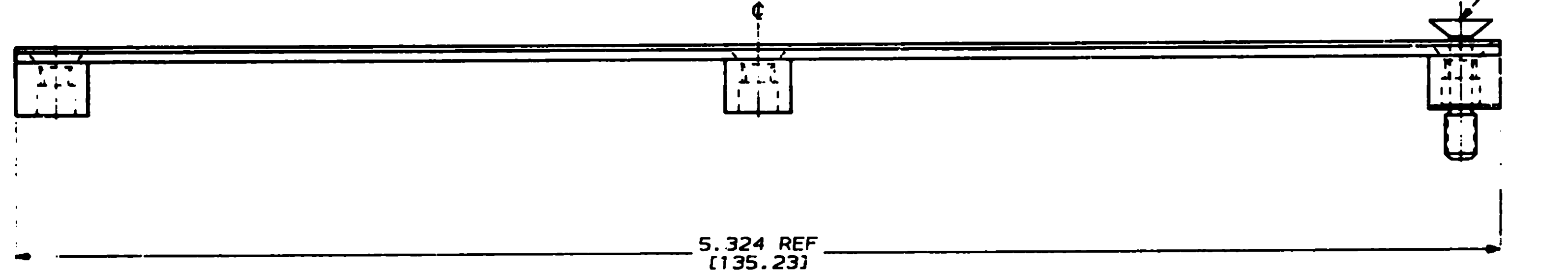

447007-1
PART NO

DO NOT SCALE PRINT. UNLESS SPECIFIED DIMENSIONS IN INCHES (mm) TOLERANCES ON: 2 PLC DEC ± .005 (0.13) ANGLES ± 1°	DR 12-13-89 R.W. BLAIR	AMP INCORPORATED Harrisburg, Pa. 17115	NAME SHELL ASSEMBLY, A-SIDE, HDI-6ROW
	CHK 01-1-90 J.M. NORTON		
MATERIAL	APPD 01-02-90 J.M. NORTON	PRODUCT SPEC	SITE D
FINISH	APPD 01-02-90 D.E. SMITH		
	APPLICATION SPEC	SCALE 3:1	FORM NO 447007
	WEIGHT		SHEET 1 OF 1