

THIS DRAWING IS UNPUBLISHED. RELEASED FOR PUBLICATION
 © COPYRIGHT - By - ALL RIGHTS RESERVED.

LOC		DIST		REVISIONS			
P	LTR	DESCRIPTION		DATE	DWN	APVD	
AF	50	F		REVISED PER ECR-12-013219	08JAN13	KH	KR

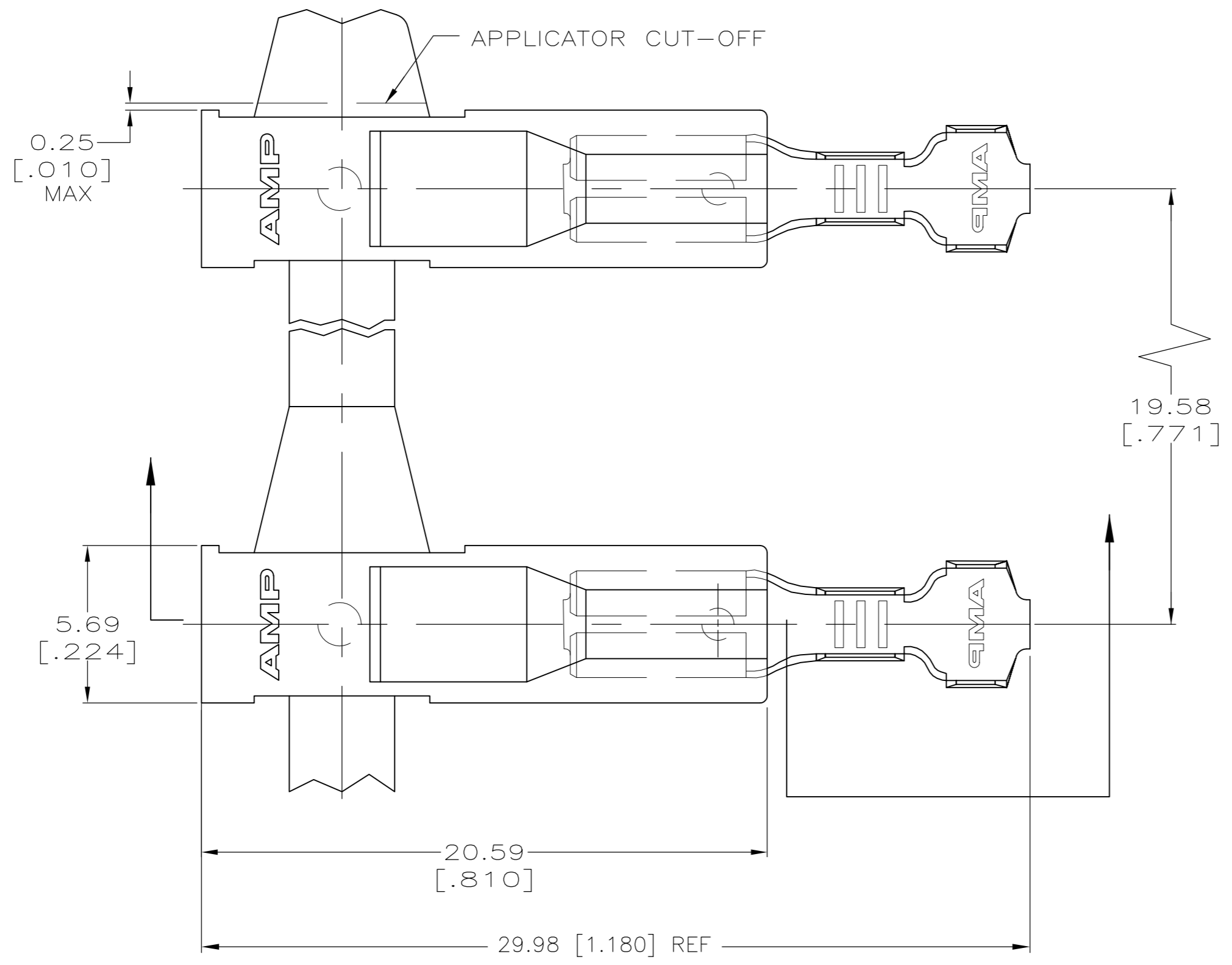

- 1 MATING TAB THK IS 0.81±0.025[.032±.001]
- 2 WIRE SIZE IS [#22-#18] AWG.
- 3 INSULATION RANGE IS 2.03-3.05[.080-.120] DIA.
- 4 PREPRODUCTION - FASR REQ

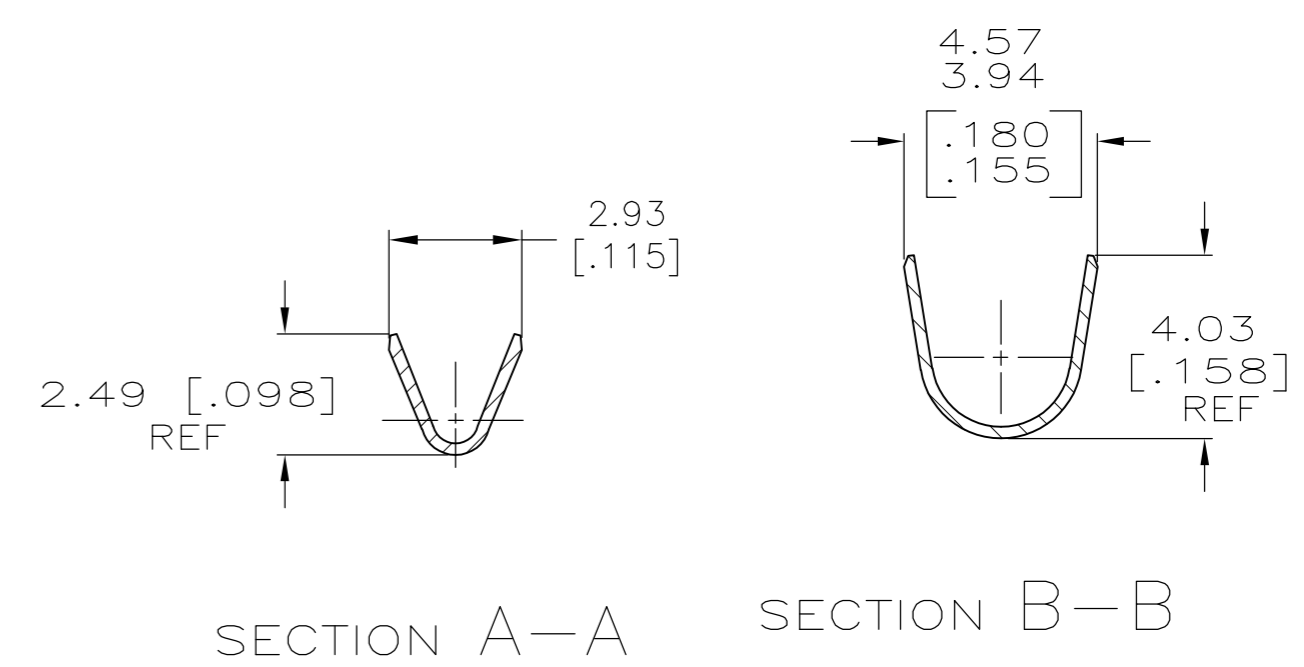
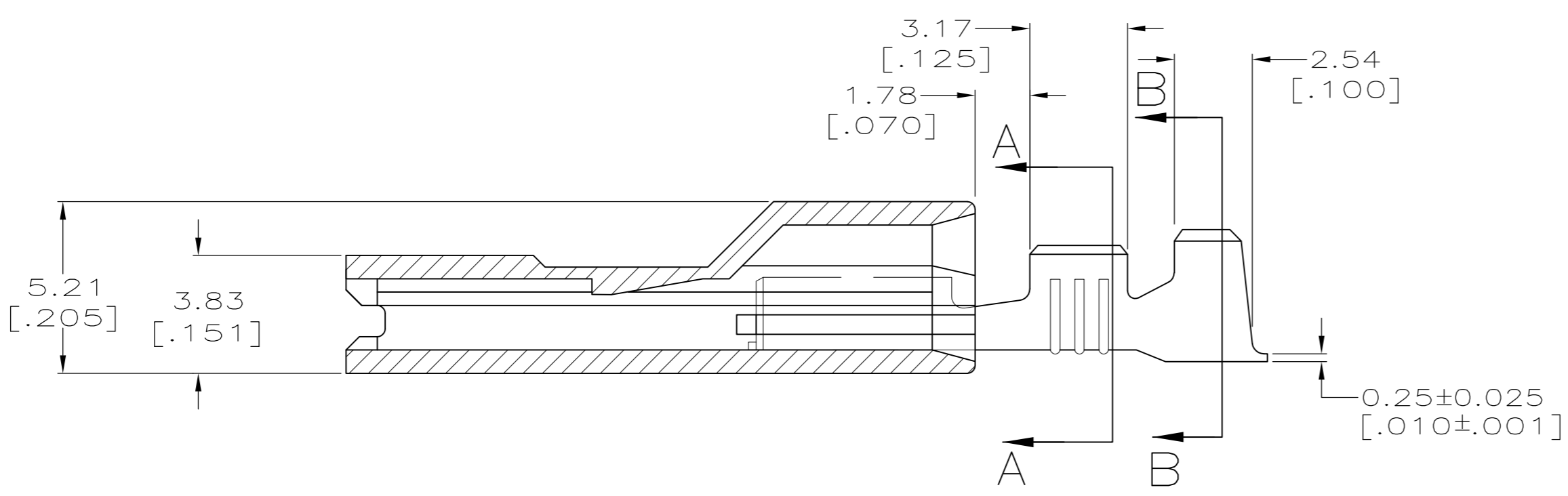

0.002032 [.000080] MIN TIN		521437-2	
-		4 521437-1	
TERMINAL FINISH		PART NO.	
DWN JR RUTH 22OCT01		TE Connectivity	
CHK J HUMMEL 22OCT01			
APVD J HUMMEL 22OCT01		NAME	
PRODUCT SPEC 108-1285		ASSEMBLY, RECEPTACLE, ULTRA-POD, 2.79 [.110] SERIES	
APPLICATION SPEC 114-2124		SIZE A2	CAGE CODE 00779
MATERIAL TERM - BRASS HSG - 6/6 NYLON, VO		DRAWING NO C=521437	RESTRICTED TO -
FINISH SEE TABLE HSG - WHITE		SCALE 6:1	SHEET 1 OF 1
CUSTOMER DRAWING		REV F	

THIS DRAWING IS A CONTROLLED DOCUMENT.	
DIMENSIONS: mm [INCHES]	TOLERANCES UNLESS OTHERWISE SPECIFIED:
	0 PLC ± -
	1 PLC ± -
	2 PLC ± 0.25 [.010]
	3 PLC ± -
	4 PLC ± -
ANGLES ± -	